

STANLEY

®

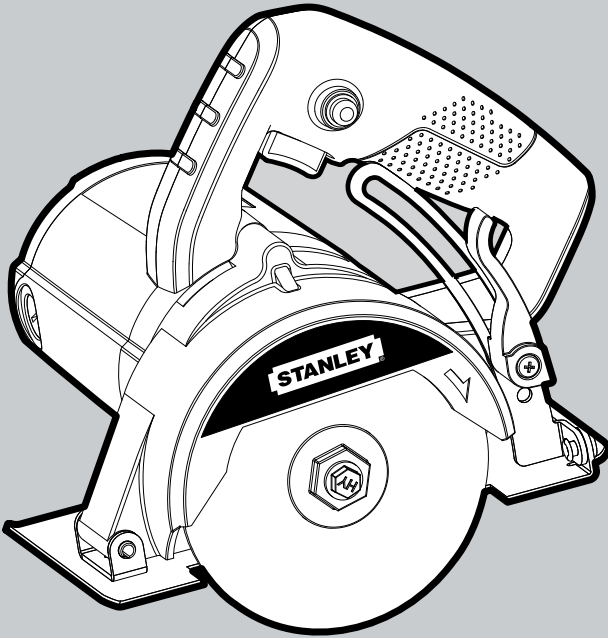

STEL785

English
繁體中文

3
7

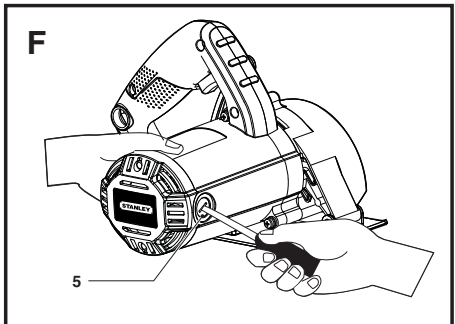
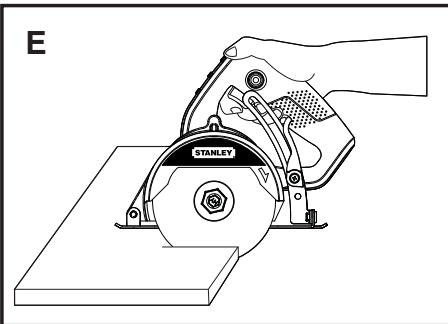
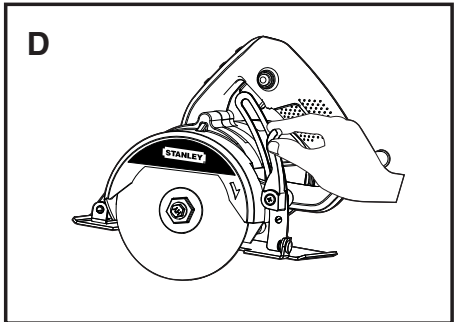
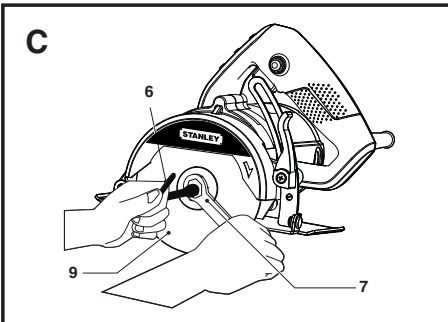
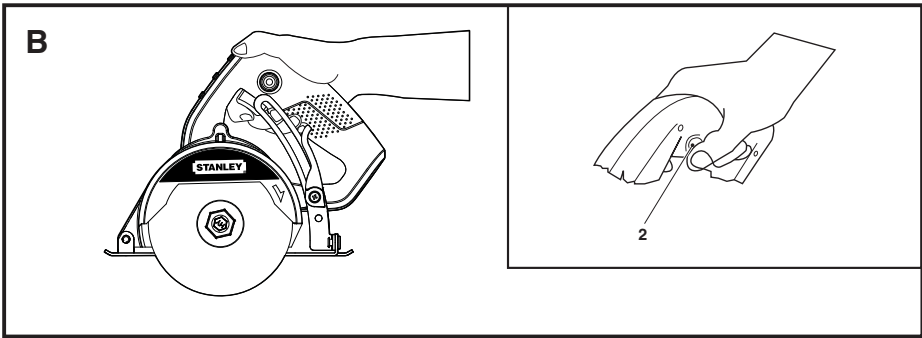
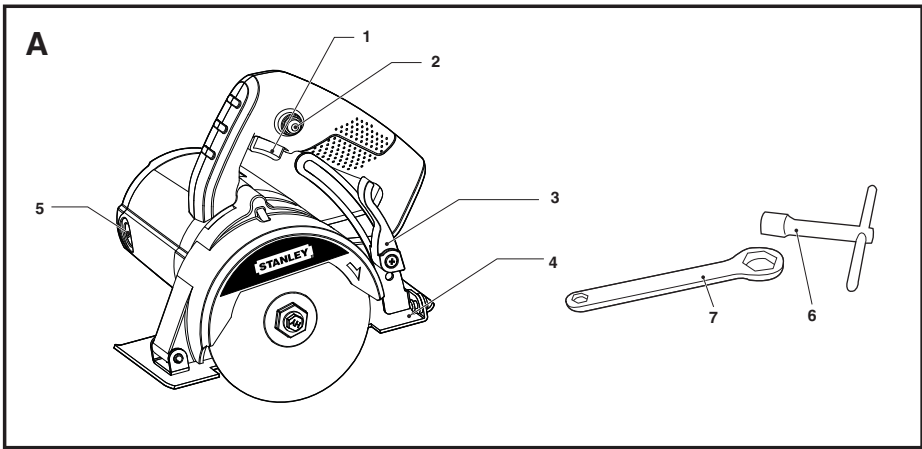

STEL785 110mm Tile/Marble Cutter

TECHNICAL DATA

SPECIFICATION	STEL785	
POWER	W	1,200
NO-LOAD SPEED	/min	13,500
WHEEL DIAMETER	mm	110
MAX. DEPTH OF CUT	mm	34
WEIGHT	kg	2.69
CABLE LENGTH	m	3

INTENDED USE

Your Stanley tile cutter has been designed for cutting applications.

GENERAL SAFETY RULES

Warning! Read all instructions. Failure to follow all instructions listed below may result in electric shock, fire and/or serious injury. The term "power tool" in all of the warnings listed below refers to your mains operated (corded) power tool or battery operated (cordless) power tool.

SAVE THESE INSTRUCTIONS.

1. Work area

- Keep work area clean and well lit.** Cluttered and dark areas invite accidents.
- Do not operate power tools in explosive atmospheres, such as in the presence of flammable liquids, gases or dust.** Power tools create sparks which may ignite the dust or fumes.
- Keep children and bystanders away while operating a power tool.** Distractions can cause you to lose control.

2. Electrical safety

- Power tool plugs must match the outlet. Never modify the plug in any way. Do not use any adapter plugs with earthed (grounded) power tools.** Unmodified plugs and matching outlets will reduce risk of electric shock.
- Avoid body contact with earthed or grounded surfaces such as pipes, radiators, ranges and refrigerators.** There is an increased risk of electric shock if your body is earthed or grounded.
- Do not expose power tools to rain or wet conditions.** Water entering a power tool will increase the risk of electric shock.
- Do not abuse the cord. Never use the cord for carrying, pulling or unplugging the power tool. Keep cord away from heat, oil, sharp edges or moving parts.** Damaged or entangled cords increase the risk of electric shock.
- When operating a power tool outdoors, use an extension cord suitable for outdoor use.** Use of a cord suitable for outdoor use reduces the risk of

electric shock.

- If operating a power tool in a damp location is unavoidable, use a residual current device (RCD) protected supply.** Use of an RCD reduces the risk of electric shock.
- Personal safety**
 - Stay alert, watch what you are doing and use common sense when operating a power tool. Do not use a power tool while you are tired or under the influence of drugs, alcohol or medication.** A moment of inattention while operating power tools may result in serious personal injury.
 - Use safety equipment. Always wear eye protection.** Safety equipment such as dust mask, non-skid safety shoes, hard hat, or hearing protection used for appropriate conditions will reduce personal injuries.
 - Avoid accidental starting. Ensure the switch is in the off position before plugging in.** Carrying power tools with your finger on the switch or plugging in power tools that have the switch on invites accidents.
 - Remove any adjusting key or wrench before turning the power tool on.** A wrench or a key left attached to a rotating part of the power tool may result in personal injury.
 - Do not overreach. Keep proper footing and balance at all times.** This enables better control of the power tool in unexpected situations.
 - Dress properly. Do not wear loose clothing or jewellery. Keep your hair, clothing and gloves away from moving parts.** Loose clothes, jewellery or long hair can be caught in moving parts.
 - If devices are provided for the connection of dust extraction and collection facilities, ensure these are connected and properly used.** Use of these devices can reduce dust related hazards.
 - Power tool use and care**
 - Do not force the power tool. Use the correct power tool for your application.** The correct power tool will do the job better and safer at the rate for which it was designed.
 - Do not use the power tool if the switch does not turn it on and off.** Any power tool that cannot be controlled with the switch is dangerous and must be repaired.
 - Disconnect the plug from the power source and/or the battery pack from the power tool before making any adjustments, changing accessories, or storing power tools.** Such preventive safety measures reduce the risk of starting the power tool accidentally
 - Store idle power tools out of the reach of children and do not allow persons unfamiliar with the power tool or these instructions to**

starting the power tool accidentally

- d. **Store idle power tools out of the reach of children and do not allow persons unfamiliar with the power tool or these instructions to operate the power tool.** Power tools are dangerous in the hands of untrained users.
 - e. **Maintain power tools. Check for misalignment or binding of moving parts, breakage of parts and any other condition that may affect the power tools operation. If damaged, have the power tool repaired before use.** Many accidents are caused by poorly maintained power tools.
 - f. **Use the power tool, accessories and tool bits etc., in accordance with these instructions, taking into account the working conditions and the work to be performed.** Use of the power tool for operations different from those intended could result in a hazardous situation.
5. **Service**
- a. **Have your power tool serviced by a qualified repair person using only identical replacement parts.** This will ensure that the safety of the power tool is maintained.

Additional Safety Instructions for Tile/Marble Cutters



⚠ CAUTION: Hold tool by insulated gripping surfaces when performing an operation where the cutting tool may contact hidden wiring or its own cord. Contact with a "live" wire will make exposed metal parts of the tool "live" and shock the operator.

- 1. **Always keep your hands away from the cutting area and the diamond disk.** Always keep the other hand on the side handle. If you hold the tool with both hands, your hands will not be injured by the disk.
- 2. **Do not touch the underside of the work** because the guard cannot protect the part of the disk under the work.
- 3. **Always use a diamond disk with well-matched size and center (diamond or circular shape).** Mismatched disk and holder will result in eccentric operation out of control.
- 4. **Do not use any washer or bolt that is damaged or unfit in size;** otherwise you will lose control of operation.
- 5. **Do not use any grinding wheel.**
- 6. **Do not use any diamond disc that does not conform to the Manufacturer's stipulations.**
- 7. **Do not use any cutting disk that has been damaged, distorted or cracked.**
- 8. **Do not operate the tool without the fixed guard.**

- 9. **Do not start the tool with the disk touching the work.**
- 10. **When switching off the tool, do not put down the tool until the disc completely stops running, nor should any external force be exerted to stop the disk.**
- 11. **Disconnect the plug from the power source and ensure the diamond disk stand still when replacing the disc, adjusting the cutting depth or water pipe, or repairing the tool.**
- 12. **Only hold the tool by its insulated gripping surface when the diamond disk is possibly cutting through concealed wires or its own cord.** If the diamond disk touches a "live" wire, the tool's exposed metal parts may be energized and thus shock the operator.
- 13. **Be especially cautious when "blind cutting" through walls or other blind areas** because the diamond disk may cut gas or water piping, wires or resilient objects.

Symbols

The label on your tool may include the following symbols:

To reduce the risk of injury, the user must read the instruction manual
VVolts
AAmperes
HzHertz
WWatts
minminutes
~Alternating current
—Direct current
n ₀No load speed
Class II Construction
Safety alert symbol
.../minRevolutions or reciprocations per minute

Double Insulation

The tool is double insulated. This means that all the external metal parts are electrically insulated from the mains power supply. This is done by placing insulated barriers between the electrical and mechanical components so as to making unnecessary for the tool to be earthed.

NOTE: Double insulation does not take the place of normal safety precautions when operating this tool. The insulation system is for added protection against injury resulting from a possible electrical insulation failure within the tool.

Electrical Safety

The electric motor has been designed for one voltage only. Always check that the power supply corresponds to the voltage on the rating plate.

Using an Extension Cable

An extension cable should not be used unless absolutely necessary. Use of an improper extension cable could result in a risk of fire and electric shock. If an extension cable must be used, use only those that are approved by the country's Electrical Authority. Make sure that extension cord is in good condition before using. Always use the cord that is suitable for the power input of your tool (see technical data on name plate). The minimum conductor size is 1mm²; the maximum length is 30m. When using a cable reel, always unwind the cable completely.

Features (Fig. A)

1. On / off switch
2. Lock-on button
3. Depth-of-cut adjustment lever
4. Base
5. Brush Cap
6. Socket wrench
7. Spanner

Assembly and Adjustment

 Prior to assembly and adjustment always unplug the tool.

Fitting & Removing the Diamond Wheel (Fig. C)

Fitting

- Insert the diamond wheel (9) to the spindle.
- Grip outside flange with spanner (7) and turn socket wrench (6) counterclockwise.

 Be sure to tighten clamp bolt securely.

 Use only the recommended diamond wheel with the correct hole size.

Removing

- Follow the procedure above in reverse order.

Cutting Depth Adjustment (Fig. D)

- To increase or decrease the depth of cut, loosen by pulling the Depth-of-cut adjustment lever (3) down.
- For minimum depth of cut, move/slide wing nut towards the "-" sign.
- To increase the depth of cut, move adjustment lever upwards, away from the base.
- At the desired depth of cut, secure the base by tightening the adjustment lever.
- At anytime, the depth-of-cut adjustment knob can also be set to a desired position to suit the user.

Instruction for Use

 Always observe the safety instructions and applicable regulations.

 Ensure that the depth-of-cut adjustment lever (3) is properly tightened before operating the tool.

Switching On And Off (Fig. E)

- To switch the tool on, press the on/off switch (1).
- To switch the tool off, release the on/off switch. This tool has a lock-on feature.
- To activate press the on/off switch and the then lock-on button (2).
- To de-activate press the on/off button again. Always switch off the tool when work is finished and before unplugging.

Cutting (Fig. E)

- Align the edge of the front of the base with the cutting line on the work piece. Hold the tool firmly.
- Set the base on the work piece to be cut without the wheel making any contact.
- Turn tool on and wait until the wheel attains full speed.
- Move the tool forward over the work piece surface, advancing smoothly until the cut is completed.
- Keep the cutting line straight.
- **This tool should only be used on horizontal surfaces.**
- Be sure to move the tool gently forward, in a straight line. Forcing, or exerting excessive pressure, or allowing the wheel to bend, pinch or twist in the cut can cause the motor to over heat and tool to kickback dangerously.
- **When cutting the work piece over 20mm deep, make 2 or 3 separate cuts to prevent motor failure.**

Maintenance

Your Stanley power tool has been designed to operate over a long period of time with a minimum of maintenance. Continuous satisfactory operation depends upon proper tool care and regular cleaning.

Motor Brushes (Fig. F)

- Remove and check carbon brushes regularly. Replace when they have worn down to about 6mm or less.
- Keep carbon brushes clean for free movement in the holder. Both carbon brushes should be replaced at the same time.
- Use only Stanley carbon brushes. Use a screwdriver to remove brush caps (5).
- Take out worn brushes, insert new ones, and secure the brush caps.

Cleaning

 **Warning:** unplug the tool before you use a cloth to clean the housing. With the motor running, blow dirt and dust out of all air vents with dry air at least once a week. Wear safety glasses when performing this. Exterior plastic parts may be cleaned with a damp cloth and mild detergent. Although these parts are highly solvent resistant, NEVER use solvents.

Tool Care

Avoid overloading the machine. Overloading will result in a considerable reduction in speed and efficiency and the unit will become hot. In this event, run the machine at no load for a minute or two until cooled to normal working temperature by the built in fan. Switching your machine on and off whilst under load will considerably reduce the life of the switch.

Important

To ensure product SAFETY and RELIABILITY, repairs, maintenance and adjustment (other than those listed in this manual) should be performed by authorized service centers or other qualified organizations, always using identical replacement parts. Unit contains no user serviceable parts inside.

Accessories

The performance of any power tool is dependent upon the accessory used. Stanley accessories are engineered to high quality standards and are designed to enhance the performance of power tool. Stanley offers a large selection of accessories available at our local dealer or authorized service center at extra cost.

Note: use only accessories rated at least equal to the maximum speed marked on the tool.

 **CAUTION:** The use of any other accessory not recommended for use with this tool could be hazardous.

 **No grinding disc is allowed to use on this tool.**

 **No wood-cutting disc is allowed on this tool.**

Protecting The Environment

 Should you find one day that your tool needs replacement, or if it is of no further use to you, think of the protection of the environment. Stanley recommends you to contact your local council for disposal information.

Service Information

Stanley offers a full network of company-owned and authorized service locations throughout Asia. All Stanley Service Centers are staffed with trained personnel to provide customers with efficient and reliable power tool service. Whether you need technical advice, repair, or genuine factory replacement parts, contact the Stanley location nearest to you.

Notes

- Stanley's policy is one of continuous improvement to our products and, as such, we reserve the right to change product specifications without prior notice.
- Standard equipment and accessories may vary by country.
- Product specifications may differ by country.
- Complete product range may not be available in all countries.
- Contact your local Stanley dealers for range availability.

STEL785 切石機

技術參數

規格	STEL785	
功率	瓦	1,200
空載速度	轉 / 分	13,500
直徑	毫米	110
切割深度	毫米	34
重量	公斤	2.69
電線長度	米	3

一般安全規則

⚠警告！ 閱讀說明沒有按照以下列舉的說明而使用或操作將導致觸電、著火和/或嚴重傷害。在所有以下列舉的警告中術語“電動”工具指市電驅動（有線）電動工具或電池驅動（無線）電動工具。

保存這些說明

a) 工作場地

1. **保持工作場地清潔和明亮。** 混亂和黑暗的場地會引發事故。
2. **不要在易爆環境，如有易燃液體、氣體或粉塵的環境下操作電動工具。** 電動工具產生的火花會點燃粉塵或氣體。
3. **讓兒童和旁觀者離開後操縱電動工具。** 分心會使你放鬆控制。

b) 電氣安全

1. **電動工具插頭必須與插座相配。** 絕不能以任何方式改裝插頭。需接地的電動工具不能使用任何轉換插頭。未經改裝的插頭和相配的插座將減少觸電危險。
2. **避免人體接觸接地表面，如管道、散熱片和冰箱。** 如果你身體接地會增加觸電危險。
3. **不得將電動工具暴露在雨中或潮濕環境中。** 水進入電動工具將增加觸電危險。
4. **不得濫用電線。** 絕不能用電線搬運、拉動電動工具或拔出其插頭。讓電動工具遠離熱、油、銳邊或運動部件。受損或纏繞的電線會增加觸電危險。

5. **當在戶外使用電動工具時，使用適合戶外使用的外接電線。** 適合戶外使用的電線將減少觸電危險。

c) 人身安全

1. **保持警覺，當操作電動工具時關注所從事的操作並保持清醒。** 切勿在有疲倦、藥物、酒精或治療反應下操作電動工具。在操作電動工具期間精力分散會導致嚴重人身傷害。
2. **使用安全裝置。** 始終配戴護目鏡。安全裝置，諸如適當條件下的防塵面具、防滑安全鞋、安全帽、聽力防護等裝置能減少人身傷害。
3. **避免突然起動。** 確保開關在插入插頭時處於**關斷位置**。手指放在已接通電源的開關上或開關處於接通時插入頭可能會導致危險。
4. **在電動工具接通之前，拿掉所有調節鑰匙或扳手。** 遺留在電動工具旋轉零件上的扳手或鑰匙會導致人身傷害。
5. **手不要伸得太長。** 時刻注意腳下和身體平衡。這樣在意外情況下能很好地控制電動工具。
6. **著裝適當。** 不要穿寬鬆衣服或佩帶飾品。讓你的頭髮、衣服和袖子遠離運動部件。寬鬆衣服、佩飾或長發可能會捲入運動部件。
7. **如果提供了與排屑裝置、集塵設備連接用的裝置，則確保他們連接完好且使用得當。** 使用這些裝置可減少碎屑引起的危險。

d) 電動工具使用和注意事項

1. **不要濫用電動工具，根據用途使用適當的電動工具。** 選用適當的設計額值的電動工具會使你工作有效、更安全。
2. **如果開關不能接通或關斷工具電源，則不能使用該電動工具。** 不能用開關來控制的電動工具是危險的且必須進行修理。
3. **在進行任何調節、更換附件或貯存電動工具之前，必須從電源上拔掉插頭和 / 或將電池盒脫開電源。** 這種防護性措施將減少電動工具突然起動的危險。
4. **將閒置電動工具貯存在兒童所及範圍之外，並且不要讓不熟悉電動工具或對這些說明不了解的人操作電動工具。** 電動工具在未經訓練的用戶手中

是危險的。

5. 保養電動工具。檢查運動部件的安裝偏差或卡住、零件破損情況和影響電動工具運行的其它條件。如有損壞，電動工具必須在使用前修理好。許多事故由維護不良的電動工具引發。
6. 保持切削刀具鋒利和清潔。保養良好的有鋒利切削刃的刀具不易卡住而且容易控制。
7. 按照使用說明書以及打算使用的電動工具的特殊類型要求的方式，考慮作業條件和進行的作業來使用電動工具、附件和工具的刀頭等。電動工具用作那些與要求不符的操作可能會導致危險情況。

e) 維修

1. 將你的電動工具送交專業維修人員，必須使用同樣的備件進行更換。這樣確保所維修的電動工具的安全性。

切石機的附加安全守則

⚠️ 小心！ 當鋸割牆壁、地板或任何可接觸到電線機會的時候，切勿接觸鋸機的金屬部份！使用電動工具時，應拿著其絕緣表面，因機具可能會接觸到隱藏的電源線或自身電線，接觸帶電的電線，可使工具的金屬露部件也帶電，並電擊操作者。

1. 讓手始終遠離鋸割區域和金剛石鋸片。你的另一隻手始終握住輔助手柄。如果雙手都握住切割機，就不會被鋸片傷害。
2. 不得接觸工件的下面。護罩無法防護工件下方的鋸片。
3. 始終使用尺寸和軸心形狀（菱形或圓形）配合得當的金剛石鋸片。如果金剛石鋸片與切割機夾裝部件不符將引起偏心運轉而導致失控。
4. 不得使用損壞的和尺寸不符的墊圈和螺栓。使用損壞的或尺寸不符的墊圈和螺栓會導致操作失控。
5. 不得使用砂輪；
6. 不得使用不符合製造商規定的金剛石鋸片；
7. 不得使用破損、變形或有裂痕的切割片；
8. 不得在拆除固定護罩的狀態下運行；
9. 不得在切割片與工件接觸的情況下起動切割機；

10. 切割機斷電後，在切割片完全停轉之前，不要放下切割機，且不得用任何外力迫使金剛石鋸片停轉；
11. 更換切割片、調節切割深度或水管、或維修切割機前，應將插頭從電源上拔脫，金剛石鋸片處於靜止狀態；
12. 當在金剛石鋸片有可能切割到暗線或自身電線的場所進行操作時，只能通過絕緣握持面來握住電動工具。金剛石鋸片碰到帶電導線可能會使電動工具的外露金屬零件帶電並使操作者受到電擊危險；
13. 當進行“盲切割”進入牆體或其它盲區時要格外小心。金剛石鋸片可能會割到煤氣管或水管，電線或由此引起反彈的物體。

警告標誌

工具上的標誌和符號：

 閱讀使用手冊
V 伏特
A 安培
Hz 赫茲
W 瓦特
min 分鐘
~ 交流電
— 直流電
n ₀ 空載速度
 II 雙重絕緣
 安全警示標誌
.../min 每分鐘的旋轉運動或往復運動次數

雙重絕緣

 本工具是雙重絕緣的；有關電動及機械部份均以額外的絕緣體隔開，因此，所有外部的金屬部份都是與電分隔的。雙重絕緣能使電器更加安全，而且無需接地線。注意：雙重絕緣不能代替使用本工具的正常安全措施，它只是對工具的可能電力絕緣失效而多加的一重保護而已。

電氣安全

使用前，檢查並確保電源電壓與銘牌上的使用電壓相符。

使用延長線

如非必要，請勿使用延長線。使用不正確的延長線會引致火災或電擊的危險。如果非要使用不可，請用當地電力機構認可的延長線。使用前先確定延長線的性能良好，並且符合工具的電源輸入（見銘牌上的技術數據）。延長線的電線導體部分尺寸應不小於1.5平方毫米。

部件（圖A）

本工具乃設計以作專業鋸割磁磚、石材等

1. 開關
2. 鎖定鈕
3. 深度調整鈕
4. 底板
5. 碳刷蓋
6. 套筒扳手
7. 扳手

組裝和調整

組裝和調整前，先要切斷電源。

裝卸鋸片（圖C）

安裝

- 把鋸片（9）穿進主軸。
- 用扳手（7）套住外法蘭，然後用套筒扳手（6）逆時針方向轉動螺絲。

⚠ 確保緊固螺絲已鎖緊。

⚠ 只可使用符合孔径尺寸的金剛石切割片。

卸下

- 按上述安裝步驟反向執行。

調整切割深度（圖D）

- 要增加或減少切割深度，只需鬆開深度調整鈕（3）。
- 切割最小深度時，將調整鈕朝“—”的方向推動；

- 若要增加切割深度，將調整鈕向下推動，使它接近底板。
- 當到達所需的切割深度時，轉緊深度調整鈕以固定深度。
- 為防止工具發生任何故障，深度調整鈕已在出廠前被調到最佳位置。
- 用戶也可根據需要在任何時候將其調到所需位置。

使用指南

- 請遵守安全指示及相關條例。
- 使用工具前，必先確定深度調整鈕（3）已鎖緊。

開關（圖E）

- 要啟動工具，按壓開關（1）。
- 要止動工具，釋放開關。
- 本工具備有鎖定設計，要持續切割，按壓開關後再按下鎖定鈕（2）。要免除鎖定工具持續轉動，只需再按開關便可。
- 當工作完畢，務心先關掉工具再切斷電源。

切割（圖E）

- 底板前緣對準工件的切割線，拿穩工具，將底板放在所要切割工件的表面上，留心鋸片勿要接觸工件。
- 啟動工具並等鋸片達致極速。
- 將工具工件表面平穩地向前移動，直至切割完成。
- 需保持直線切割。
- **工具只能切割水平放置的工件。**
- 向前移動工具時，必定要平穩，成一直線。
- 切割中如用力過猛或使鋸片彎曲，擠壓或扭曲都會使工具熱及突然逆轉而非非常危險。
- 切割深度超過20毫米時，應分兩次或三次切割以防止馬達故障。

維護

您的 Stanley 電動工具設計精良，可以長期使用，僅需極少維護。要連續獲得令人滿意的工作效果，需要您做合適的保養和定期的清潔。您的工具不可由用戶進行維修。請將工具交給授權的 Stanley 修理機構。此工具應定期維修，或當其顯示出明顯的性能改變時進行維修。

碳刷

碳刷 (圖E)

- 定期卸下碳刷並檢查，當其磨損到六毫米或以下時，應予以更換。
- 保持碳刷乾淨，以使其在支架內移動而不受任何阻礙；兩個碳刷應同時更換。
- 只可使用百得碳刷。
- 使用一字起子卸下碳刷蓋 (5)，取出磨損的碳刷，裝入新的碳刷，然後蓋上鎖緊碳刷蓋。

清潔

△警告：用布清潔外殼之前，請拔下工具的插頭。至少每週一次，在馬達運轉時，用乾燥的壓縮空氣將灰塵和粉塵從所有的通風口吹走。進行此操作時，請佩戴護目鏡。可以用濕布和溫和的洗滌劑清潔外部的塑料部件。雖然這些部件具有很高的抗溶劑性，但切勿使用溶劑清潔。

保養

避免電動工具長期過載。過載會減低工作速度及效率，並使電動工具過熱；在此情況下，讓電動工具空載轉一兩分鐘，直至電動工具被其內至風扇冷卻到正常工作溫度。在負載情況下開或關機，會在某種程度上減低電動工具的壽命。

重要說明

為確保產品的安全性和可靠性，應由授權的維修中心或其它合格組織修理、維護和調整（非本手冊所列項目）機器，並始終使用相同的備件。裝置內不含有用戶可維修部件。

配件

任何電動工具的性能是依賴使用得當的配件的，

Stanley 的配件都是經精心設計，並以最佳物料製造、再經無數次嚴謹的測試合格才推出市場的；故其質量一等一，務求與電動工具相輔相成。購買 Stanley 配件會令您的電動工具如虎添翼。推薦的配件，在當地的經銷商或授權的維修中心人售。Stanley 有一系列的配件，在當地的經銷商及維修中心以供閣下選購。

△注意：使用鋸片的轉速至少不低於工具所標明的轉速。

△警告：本電動工具使用任何未經推薦的配件，均可能導致危險。

△警告：只可使用石材切割的金剛石切割片。不得使用砂輪或帶齒鋸片。

保護環境

 一旦您發現工具需要更換，或工具不能再使用，請考慮到保護環境。Stanley 建議您與當地相關機構聯繫，以諮詢相關的處理信息。

維修信息

Stanley 為您提供我們在全亞洲公司所有的和公司授權的維修點網絡。所有的 Stanley 維修中心均配備訓練有素的人員，可為客戶提供高效可靠的電動工具維修。無論您需要的是技術建議、修理還是原廠備件，均可聯繫最近的 Stanley 維修點為您服務。

注意事項

- Stanley 實行的是對我們的產品持續改進的政策，因此，我們保留不另行通知即可更改產品規格的權利。
- 標準裝置和配件因國家而異。
- 產品規格會按國家而有所不同。
- 完整的產品系列不一定在所有的國家均可用。請聯繫您當地的 Stanley 經銷商，諮詢產品系列的可可用性。

進口商：新加坡商百得電動工具(股)臺灣分公司
地址：臺北市北投區裕民六路120號4F

電話：02-28201065

總經銷商：永安實業股份有限公司

地址：新北市三重區新北大道二段137號

電話：02-29994633

