

STANLEY

®

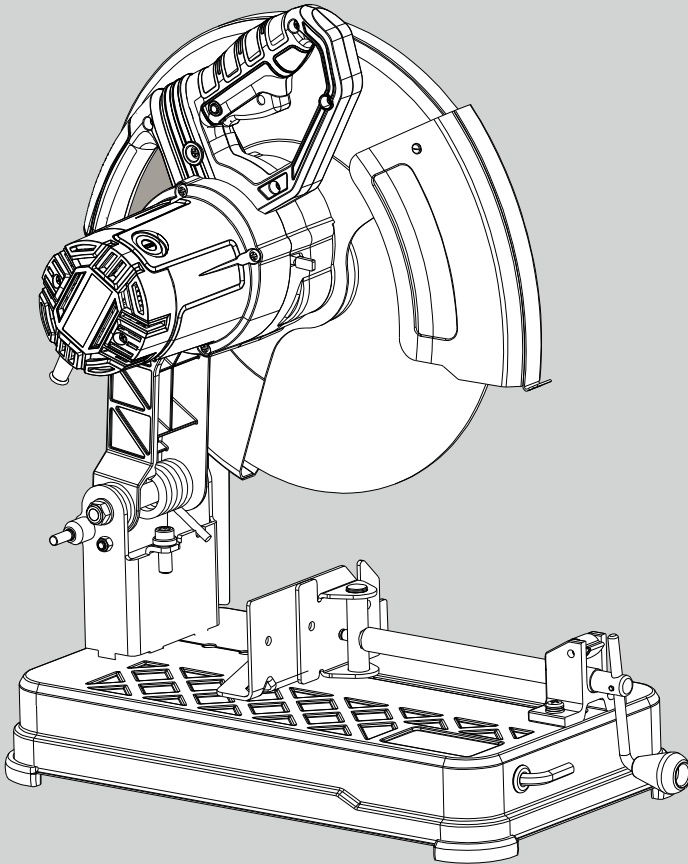

STEL701

ENGLISH
繁體中文

3
8

FIG.1

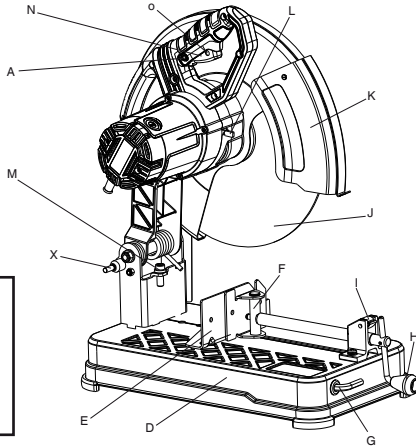

FIG.2

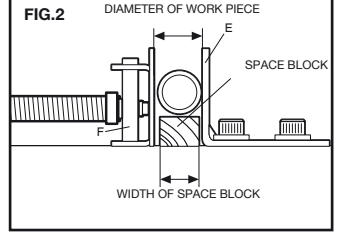

FIG.3

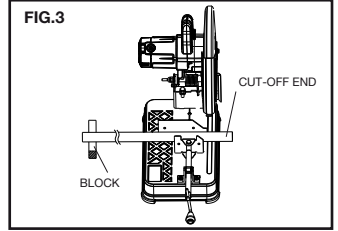

FIG.4

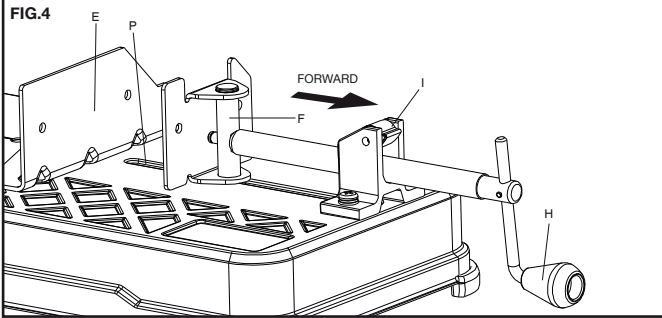

FIG.5

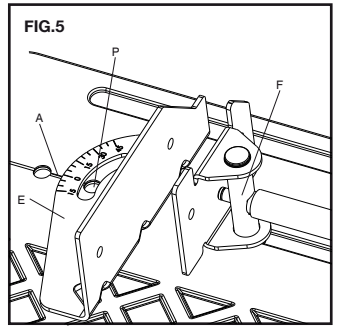

FIG.6

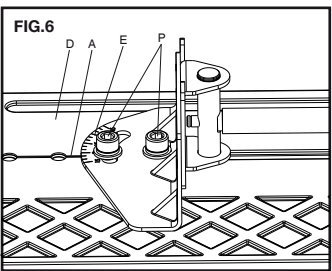

FIG.7

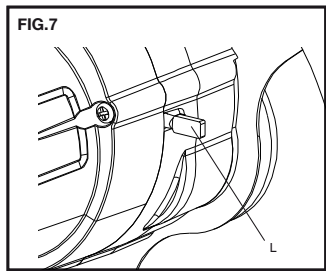

FIG.8

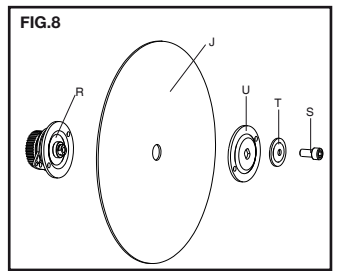
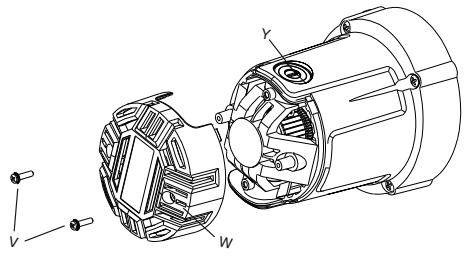
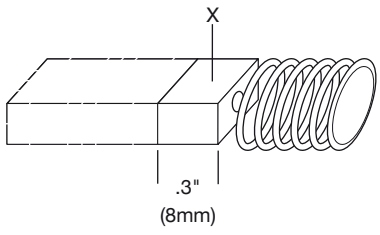

FIG.9



STEL701 2100W Chop Saw

TECHNICAL DATA

SPECIFICATION		STEL701
POWER	W	2100
NO-LOAD SPEED	/min	0-3800
MAX. DIAMETER	mm	355
Weight	kg	15.5

INTENDED USE

Your Stanley Chop saw has been designed for cutting & cleaning applications.

GENERAL SAFETY RULES

Warning! Read all instructions. Failure to follow all instructions listed below may result in electric shock, fire and/or serious injury. The term "power tool" in all of the warnings listed below refers to your mains operated (corded) power tool or battery operated (cordless) power tool. **SAVE THESE INSTRUCTIONS.**

1. Work area

- a. **Keep work area clean and well lit.** Cluttered and dark areas invite accidents.
- b. **Do not operate power tools in explosive atmospheres, such as in the presence of flammable liquids, gases or dust.** Power tools create sparks which may ignite the dust or fumes.
- c. **Keep children and bystanders away while operating a power tool.** Distractions can cause you to lose control.

2. Electrical safety

- a. **Power tool plugs must match the outlet. Never modify the plug in any way. Do not use any adapter plugs with earthed (grounded) power tools.** Unmodified plugs and matching outlets will reduce risk of electric shock.
- b. **Avoid body contact with earthed or grounded surfaces such as pipes, radiators, ranges and refrigerators.** There is an increased risk of electric shock if your body is earthed or grounded.
- c. **Do not expose power tools to rain or wet conditions.** Water entering a power tool will increase the risk of electric shock.
- d. **Do not abuse the cord. Never use the cord for carrying, pulling or unplugging the power tool. Keep cord away from heat, oil, sharp edges or moving parts.** Damaged or entangled cords increase the risk of electric shock.
- e. **When operating a power tool outdoors, use an extension cord suitable for outdoor use.** Use of a cord suitable for outdoor use reduces the risk of electric shock.

- f. **If operating a power tool in a damp location is unavoidable, use a residual current device (RCD) protected supply.** Use of an RCD reduces the risk of electric shock.

NOTE: The term "Residual Current Device (RCD)" can be replaced by "Ground Fault Circuit Interrupter (GFCI)" or by "Earth Leakage Circuit Breaker (ELCB)".

3. Personal safety

- a. **Stay alert, watch what you are doing and use common sense when operating a power tool. Do not use a power tool while you are tired or under the influence of drugs, alcohol or medication.** A moment of inattention while operating power tools may result in serious personal injury.
- b. **Use safety equipment. Always wear eye protection.** Safety equipment such as dust mask, non-skid safety shoes, hard hat, or hearing protection used for appropriate conditions will reduce personal injuries.
- c. **Avoid accidental starting. Ensure the switch is in the off position before plugging in.** Carrying power tools with your finger on the switch or plugging in power tools that have the switch on invites accidents.
- d. **Remove any adjusting key or wrench before turning the power tool on.** A wrench or a key left attached to a rotating part of the power tool may result in personal injury.
- e. **Do not overreach. Keep proper footing and balance at all times.** This enables better control of the power tool in unexpected situations.
- f. **Dress properly. Do not wear loose clothing or jewellery. Keep your hair, clothing and gloves away from moving parts.** Loose clothes, jewellery or long hair can be caught in moving parts.
- g. **If devices are provided for the connection of dust extraction and collection facilities, ensure these are connected and properly used.** Use of these devices can reduce dust related hazards.

4. Power tool use and care

- a. **Do not force the power tool. Use the correct power tool for your application.** The correct power tool will do the job better and safer at the rate for which it was designed.
- b. **Do not use the power tool if the switch does not turn it on and off.** Any power tool that cannot be controlled with the switch is dangerous and must be repaired.
- c. **Disconnect the plug from the power source and/or the battery pack from the power tool before making any adjustments, changing accessories, or storing power tools.** Such preventive safety measures reduce the risk of starting the power tool accidentally.
- d. **Store idle power tools out of the reach of children and do not allow persons unfamiliar with the power tool or these instructions to**

operate the power tool. Power tools are dangerous in the hands of untrained users.

- e. **Maintain power tools. Check for misalignment or binding of moving parts, breakage of parts and any other condition that may affect the power tools operation. If damaged, have the power tool repaired before use.** Many accidents are caused by poorly maintained power tools.
- f. **Use the power tool, accessories and tool bits etc., in accordance with these instructions, taking into account the working conditions and the work to be performed.** Use of the power tool for operations different from those intended could result in a hazardous situation.

5. Service

- a. **Have your power tool serviced by a qualified repair person using only identical replacement parts.** This will ensure that the safety of the power tool is maintained.

ADDITIONAL SAFETY INSTRUCTION FOR CHOPSAWS

- **Always wear proper eye and respiratory protection.**
- **Before using, inspect the cutting wheel for cracks or flaws. If such a crack or flaw is evident, discard the wheel. The wheel should also be inspected whenever you think the tool may have been dropped.** Flaws may cause wheel breakage.
- **When starting the tool with a new or replacement wheel or if you are unsure of the condition of the wheel, hold the tool in a well protected area and let it run for one minute.** If the wheel has an undetected crack or flaw, it should burst in less than one minute. Never start the tool with a person in line with the wheel. This includes the operator.
- **In operation, avoid bouncing the wheel or giving it rough treatment.** If this occurs, stop the tool and inspect the wheel for cracks or flaws.
- Clean your chop saw periodically following the procedure in this manual.
- Do not remove wheel guards or base.
- **ALWAYS USE THE VISE OR SPECIAL FIXTURE TO CLAMP WORK SECURELY.** Other aids such as spring, bar, or C-clamps may be appropriate for certain sizes and shapes of workpiece. Use care in selecting and placing these clamps and make a dry run before making a cut.
- Use only 14" type 1 wheels rated at 4100 rpm or higher.
- Allow cut off parts to cool before handling.
- Do not attempt to cut wood or plastic with this tool.
- **NEVER CUT MAGNESIUM WITH THIS TOOL.**

- Use chop saw in a well-ventilated area.
- Turn chop saw off before removing any pieces from the base.
- **DO NOT CUT ELECTRICALLY LIVE MATERIAL.**
- **Do not use circular saw blades or any other toothed blades with this tool.** Serious injury may result.
- **DO NOT OPERATE THIS TOOL NEAR FLAMMABLE LIQUIDS, GASES OR DUST.** Sparks or hot chips from cutting or arcing motor brushes may ignite combustible materials.
- Do not use the side of the abrasive wheel as a deburring grinder. This will substantially weaken the wheel creating an unsafe condition. The wheel may come apart.

- ⚠ **CAUTION: Wear appropriate hearing protection during use.** Under some conditions and duration of use, noise from this product may contribute to hearing loss.
- ⚠ **CAUTION:** Spark deflector will get hot. Avoid touching or adjusting while hot. Keep cordset and materials away from spark deflector.
- **Avoid prolonged contact with dust from power sanding, sawing, grinding, drilling, and other construction activities. Wear protective clothing and wash exposed areas with soap and water.** Allowing dust to get into your mouth, eyes, or lay on the skin may promote absorption of harmful chemicals.
- ⚠ **WARNING:** Always use NIOSH/OSHA approved respiratory protection appropriate for the dust exposure. Direct particles away from face and body. For your convenience and safety, the following warnings are on your Heavy-Duty 14" (355mm) Chop Saw:
- ⚠ **FOR SAFE OPERATION READ THE INSTRUCTION MANUAL.**
- **DO NOT USE TOOTHED BLADES.**
- **USE ONLY REINFORCED WHEELS RATED 4100 RPM OR HIGHER.**
- **WHEN SERVICING USE ONLY IDENTICAL REPLACEMENT PARTS.**
- **ALWAYS: WEAR EYE PROTECTION, USE GUARDS, CLAMP WORK IN VISE, USE PROPER RESPIRATORY PROTECTION.**
- **DO NOT EXPOSE TO RAIN OR USE IN DAMP LOCATIONS.**
- **ONLY USE CHOP SAW WHEEL OF A MAX. THICKNESS OF 2.8MM AND A MAX. DIAMETER OF 355mm.**

WARNING SYMBOLS

The label on your tool may include the following symbols:

- Use Eye Protection

- VVolts
- AAmperes
- HzHertz
- WWatts
- min.....minutes
- ~Alternating current
-Direct current
- n_0 No load speed
-Class II Construction
- ⊕Earthing terminal
- ⚠Safety alert symbol
- .../min.....Revolutions or reciprocations per minute

ELECTRICAL SAFETY

⚠ Warning! If the power cord is damaged, it must be replaced by the manufacturer, authorized Stanley Service Center or an equally qualified person in order to avoid damage or injury. If the power cord is replaced by an equally qualified person, but not authorized by Stanley the warranty will not be valid.

FEATURES (fig. 1, 4)

- A. Lock on Switch
- B. Spark Deflector Screw
- C. Spark Deflector
- D. Base
- E. Fence
- F. Vise
- G. Flat Wrench
- H. Crank
- I. Vise Level
- J. Wheel
- K. Guard
- L. Spindle Lock
- M. Depth Stop Bolt and Jam Nut
- N. Trigger Switch
- O. Padlock Hole
- P. Fence Bolts
- X. Lock Pin

POWER SUPPLY

Be sure your power supply agrees with the nameplate marking. A voltage decrease of more than 10% will cause a loss of power and overheating.

CUTTING CAPACITY





The wide vise opening and high pivot point provide cutting capacity for many large pieces. Use the cutting capacity chart to determine total maximum size of cuts that can be made with a new wheel.

CAUTION: CERTAIN LARGE, CIRCULAR OR

**⚠ IRREGULARLY SHAPED OBJECTS MAY REQUIRE ADDITIONAL HOLDING MEANS IF THEY CANNOT BE HELD SECURELY IN VISE.
CAUTION: DO NOT CUT MAGNESIUM WITH THIS TOOL.**

Maximum Cutting Capacity

NOTE: Capacity shown on chart assumes no wheel wear and optimum fence position.

Workpiece Shape:				
	A x B			
90° Cutting Angle	A = 4-7/8" (125mm)	A = 4-1/2" (115mm)	4-1/2" x 5-1/8" (115mm x 130mm) 4" x 7-5/8" (102mm x 188mm) 3" x 7-3/8" (76mm x 229mm)	A = 4-1/2" x 5-3/8" (115mm x 137mm)
45° Cutting Angle	A = 4-1/2" (115mm)	A = 3-13/16" (98mm)	4-1/2" x 3-13/16" 4-1/8" x 3-3/4" (105mm x 95mm)	A = 3-13/16" (95mm)

USE

Standard Equipment

- 355mm Metal Cutting Abrasive Wheel
- 1 Wheel Wrench
- 1 Instruction manual

To Carry (fig. 1)

Fold down unit to position where you can carry the saw. Push in lock pin (X) to lock arm down.

UnLocking (fig. 1)

To unlock tool and raise head, depress motor arm slightly and pull lock pin (X) out. Motor arm will then pivot upward.

Spark Deflector Adjustment (fig. 1)

To best deflect sparks away from surrounding persons and materials, loosen the screw (B), adjust the spark deflector (C) and then retighten screw. Do not allow cordset to come into contact with deflector or sparks as damage to cordset may occur.

Depth Stop (fig. 1)

Depth stop is set at the factory for a new 14" wheel to prevent wheel from cutting into the supporting surface. To allow more depth of cut, use the flat wrench provided (G) to loosen the depth stop bolt (M) and raise bolt to desired height and then turn jam nut (N) clockwise until seated firmly on the casting. Securely tighten the depth stop bolt before use.

⚠ CAUTION: When changing to a new wheel, readjust depth stop to original position to prevent cutting into supporting surface.

Trigger Switch (fig. 1)

To start the tool, depress the trigger switch (N). To turn the tool off, release the trigger switch. Keep hands and material from wheel until it has coasted to a stop. To prevent unauthorized use of tool, install a standard padlock (not included) into the padlock hole (O) located in the trigger.

Material Clamping and Supporting

- Angles are best clamped and cut with both legs resting against base.
- A spacer block slightly narrower than the work piece can be used to increase wheel utilization (Fig. 2).
- Long work pieces must be supported by a block so it will be level with top of base (Fig. 3). The cut off end should be free to fall downward to avoid wheel binding.

Vise Operation (fig. 4)

The vise (F) has a quick-travel feature. To release the vise when it is clamped tightly, turn the crank (H) counterclockwise one or two times to remove clamping pressure. Lift vise lever (I) up. Pull crank assembly out as far as desired. Vise may be pushed forward into work without cranking. Lower vise lever (I) then tighten vise (F) on work by using crank (H).

Fence Operation (fig. 5, 6)

⚠ CAUTION: Turn off and unplug the tool before making any adjustments or removing or installing attachments or accessories. Be sure the trigger switch is in the OFF position. The fence (E) can be adjusted two ways: to change desired cutting angle and to change spacing between the fence and vise.

To Change the Desired Cutting Angle

Use the wrench provided to loosen (do not remove) the two fence bolts (P). Align the desired angle indicator line with the slot line (A) in the base (D). Securely tighten both fence bolts before use. For more accurate square cuts, disconnect the power supply, loosen the two fence bolts, push arm down until wheel extends into base. Place a square against the wheel and adjust fence against the square. Securely tighten both fence bolts before use. When making a miter cut, the vise (F) may not clamp securely, depending on the thickness of the workpiece and the miter angle. Other aids (such as spring, bar or C-clamps) will be necessary to secure the work piece to the fence when

making these cuts.

To Change Spacing between The Fence and Vise

Using the wrench provided, loosen and remove the two fence bolts (P). Adjust the fence (E) to desired locations. Insert both fence bolts in provided locations. Securely tighten both fence bolts before use.

Removal and Installation of Wheels (fig. 7, 8)

- ⚠ CAUTION:** Turn off and unplug the tool before making any adjustments or removing or installing attachments or accessories. Be sure the trigger switch is in the OFF position. Do not make any adjustment while the wheel is in motion. Do not make any adjustment while chop saw is plugged into power supply.
1. Push in spindle lock (L) and rotate wheel (J) by hand until wheel lock lever engages slot in inside flange (R) to lock wheel. Loosen the bolt (S) counterclockwise in the center of the abrasive wheel with the 8mm hex wrench (G). Bolt has right-hand thread.
 2. Remove the bolt (S), washer (T), outside flange (U) and old wheel (J).
 3. Make sure flange surfaces are clean and flat. Install the new abrasive wheel by reversing the above steps.
 4. Do not overtighten bolt.

⚠ WARNING: Check the work surface that the chop saw rests on when replacing with a new abrasive wheel. It is possible that the wheel may contact ANY ITEMS OR STRUCTURE THAT EXTENDS ABOVE work surface (under the base) when the arm is fully lowered.

OPERATION TIPS FOR MORE ACCURATE CUTS

- Allow the wheel to do the cutting. Excessive force will cause the wheel to glaze reducing cutting efficiency and/or to deflect causing inaccurate cuts.
- Properly adjust fence angle.
- Make sure material is laying flat across base.
- Properly clamp material to avoid movement and vibration.

MOTOR BRUSH INSPECTION AND REPLACEMENT (FIG.9)

⚠ WARNING: Turn off and unplug the tool. Be sure the trigger switch is in the OFF position. Brushes should be regularly inspected for wear. To inspect brushes, unscrew the two end cap screws (V) and remove end cap (W). Remove brush cap (Y). Brushes (X) should slide freely in brush box. If brushes are worn down to .3" (8mm) as shown in Figure 9 they should be replaced. To reinstall, push new brush back into brushbox. If replacing existing brush, maintain same orientation as when removed. Replace the brush cap (do not overtighten). Replace end cap and two screws. Tighten securely.

MAINTENANCE

Your Stanley power tool has been designed to operate over a long period of time with a minimum of maintenance. Continuous satisfactory operation depends upon proper tool care and regular cleaning. Your tool is not user-serviceable. Take the tool to an authorized Stanley repair agent. This tool should be serviced at regular intervals or when showing a noticeable change in performance.

Lubrication

Stanley power tools are properly lubricated at the factory and are ready for use. Tools should be re-lubricated regularly, depending on usage. This lubrication should only be attempted by trained power tool repair persons, such as those at Stanley service centers or by other qualified service personnel.

Closed-type, grease-sealed ball bearings are used throughout. These bearings have sufficient lubrication-packed in them at the factory to last the life of the chop saw.

Cleaning

⚠ Warning: unplug the tool before you use a cloth to clean the housing. With the motor running, blow dirt and dust out of all air vents with dry air at least once a week. Wear safety glasses when performing this. Exterior plastic parts may be cleaned with a damp cloth and mild detergent. Although these parts are highly solvent resistant, NEVER use solvents.

Blowing dust and grit out of the main housing by means of an air hose is recommended and may be done as often as dirt is seen collecting in and around the air vents. Always wear proper eye and respiratory protection.

Tool Care

Avoid overloading the machine. Overloading will result in a considerable reduction in speed and efficiency and the unit will become hot. In this event, run the machine at no load for a minute or two until cooled to normal working temperature by the built in fan. Switching your machine on and off whilst under load will considerably reduce the life of the switch.

Important

To ensure product SAFETY and RELIABILITY, repairs, maintenance and adjustment (other than those listed in this manual) should be performed by authorized service centers or other qualified organizations, always using identical replacement parts. Unit contains no user serviceable parts inside. Blowing dust and grit out of the main housing by means of an air hose is recommended and may be done as often as dirt is seen collecting in and around the air vents. Always wear proper eye and respiratory protection.

NOTE: Unit may be converted to a 3-wire twist lock cord set at an authorized service center.

ACCESSORIES

The performance of any power tool is dependent upon the accessory used. Stanley accessories are engineered to high quality standards and are designed to enhance the performance of power tool.

Note: Accessory must be rated for use at speed equal to or higher than nameplate RPM of tool with which it is being used.

⚠ CAUTION: The use of any other accessory not recommended for use with this tool could be hazardous. Use only high-strength Type 1 organic bonded wheels rated 4100 rpm or higher. Recommended accessories for use with your tool are available at extra cost from your local dealer or authorized service center.

Protecting The Environment

 Should you find one day that your tool needs replacement, or if it is of no further use to you, think of the protection of the environment. Stanley recommends you to contact your local council for disposal information.

Service Information

Stanley offers a full network of company-owned and authorized service locations throughout Asia. All Stanley Service Centers are staffed with trained personnel to provide customers with efficient and reliable power tool service. Whether you need technical advice, repair, or genuine factory replacement parts, contact the Stanley location nearest to you.

Notes

- Stanley's policy is one of continuous improvement to our products and, as such, we reserve the right to change product specifications without prior notice.
- Standard equipment and accessories may vary by country.
- Product specifications may differ by country.
- Complete product range may not be available in all countries.
- Contact your local Stanley dealers for range availability.

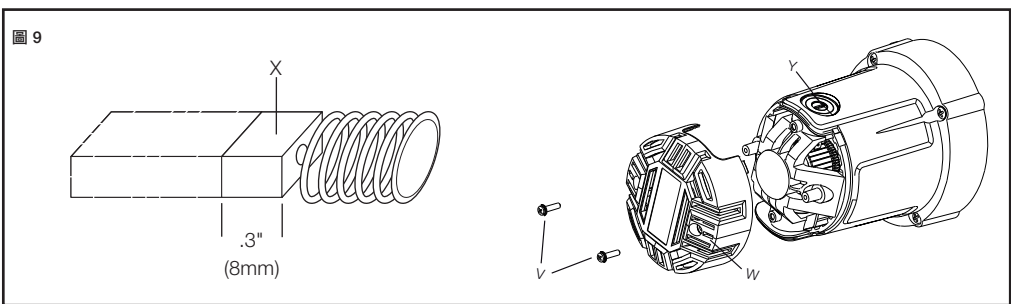
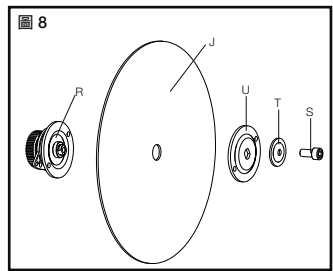
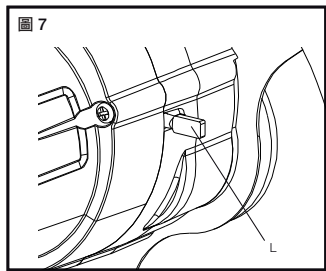
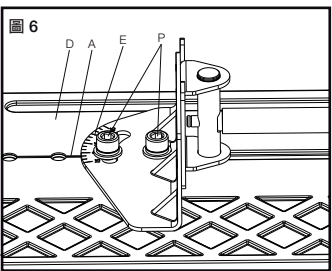
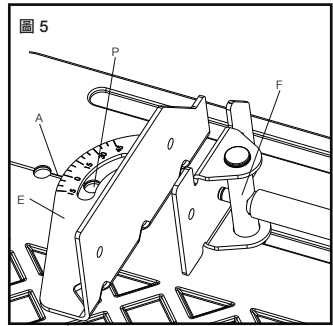
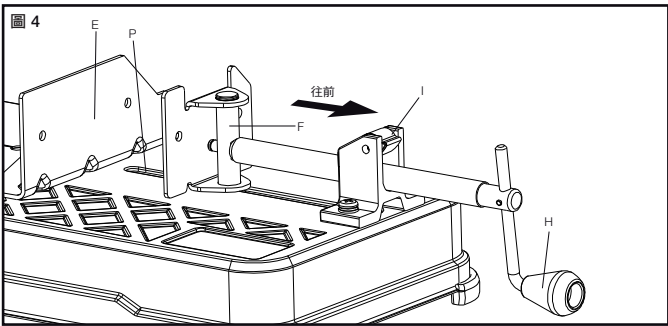
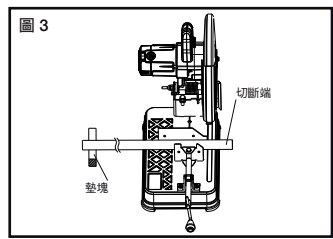
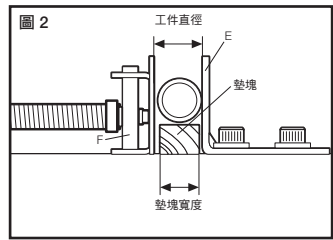
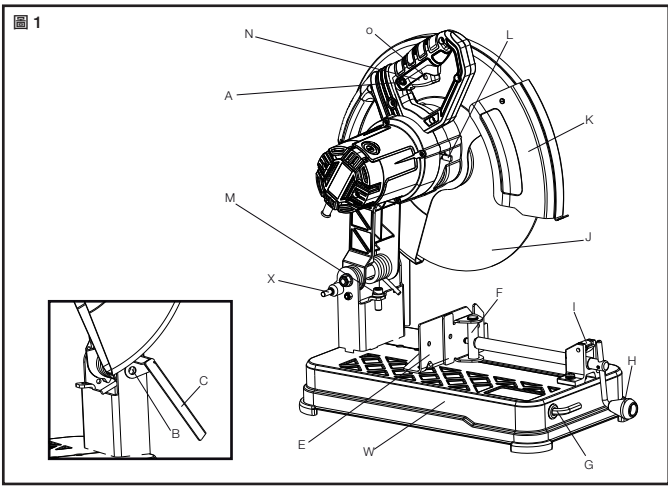

STEL701 2100W 切斷機

技術資料

產品規格	STEL701	
功率	瓦特	2100
空載轉速	轉/分	0-3800
最大直徑	毫米	355
重量	千克	15.5

設計用途

您的 Stanley 切斷機設計用於切割和清潔用途。

一般安全規則

警告！請閱讀所有指示。不遵循下列的所有指示可能會導致觸電、火災及/或嚴重傷害。下列所有警告中的名詞「電動工具」是指電源驅動（插電）電動工具，或者電池驅動（充電）電動工具。請妥善保存這些安全指示。

1. 工作場地

- 保持工作場地清潔和明亮。混亂和黑暗的場地會引發事故。
- 不要在易爆環境，如有易燃液體、氣體或塵埃的環境中操作電動工具。電動工具產生的火花會點燃塵埃或氣體。
- 請等待兒童和旁觀者離開之後才操縱電動工具。分心會導致您疏於控制。

2. 電氣安全

- 電動工具插頭必須與插座相符。請勿以任何方式改裝插頭。需接地的電動工具不能使用任何配接器插頭。未經改裝的插頭和相符的插座可以減少觸電危險。
- 避免人體接觸接地表面，如管道、散熱片、爐灶和冰箱。若您的身體接地可增加觸電危險。
- 不得將電動工具暴露在雨中或潮濕環境中。水進入電動工具會增加觸電危險。
- 請勿濫用電線。請勿使用電線來搬運、拉動電動工具或拔出插頭。讓電線遠離熱、油、銳邊或活動部件。受損或纏繞的電線可增加觸電危險。
- 若要在戶外使用電動工具，請使用適合戶外使用的延長電線。使用適合戶外使用的電線可減少觸電危險。

- 若必須在潮濕場合使用電動工具，請使用漏電保護器 (RCD)。使用 RCD 可降低觸電危險。
注：「漏電保護器 (RCD)」也為「接地故障斷路器 (GFCI)」或「接地漏電斷路器 (ELCB)」。

3. 人身安全

- 保持警覺；在操作電動工具時，請留意所執行的操作並按照一般的程式執行。不要在疲倦，或受到藥物、酒精或治療的影響下操作電動工具。操作電動工具期間注意力分散會導致嚴重人身傷害。
- 使用個人防護裝置。始終佩戴護目鏡。防護裝置，例如在適當條件下可使用的防塵面具、防滑安全鞋、安全帽或聽力保護等裝置可減少人身傷害。
- 避免意外啟動。連接電源之前，請確定開關處於關閉位置。搬運電動工具時若將手指放在開關上，或是在接通開關電源時插入插頭，都會引發危險。
- 接通電動工具之前，請卸下所有的調整鑰匙及扳手。遺留在電動工具旋轉部件上的扳手或鑰匙會導致人身傷害。
- 不要過度伸張雙手。時刻注意腳下和身體的平衡。如此即可在發生意外的情況下更好地控制電動工具。
- 適當穿著。不要穿寬鬆衣服或佩戴飾品。讓您的頭髮、衣服和手套遠離活動部件。寬鬆衣服、佩飾和長髮可能會捲入活動部件。
- 若配備用於連接排屑裝置、集塵設備的裝置，請確定正確連接和使用這些裝置。使用以上設備可減少與塵埃有關的危險。

4. 電動工具的使用與注意事項

- 不要超負荷使用電動工具。根據您的用途使用適當的電動工具。使用適當的電動工具、讓它在設計可負荷的應用內運轉，會讓您更有效、更安全地執行工作。
- 若開關不能開啟或關閉電源，請勿使用該電動工具。不能用開關來控制的電動工具將存在危險，必須進行維修。
- 在更換配件、儲存工具或執行任何調整之前，必須從電源上拔掉插頭及/或從電動工具卸下電池組。這類防護性措施可降低電動工具意外啟動的風險。
- 將閒置的電動工具儲存在兒童無法觸及的地方，並且不要讓不熟悉電動工具操作、或對這些使用指示不瞭解的人員操作電動工具。電動工具在未經培訓的使用者手中會發生危險。

- e. 維護電動工具。檢查活動部件是否對準或卡住、是否存在任何破損情況，或任何能影響電動工具運行的其他情況。若有損毀，必須在使用之前維修電動工具。許多事故都是由於電動工具欠缺維護所導致。
- f. 遵循使用指示以及工作條件和所要執行的工作使用電動工具、配件和工具刀頭等。不按照設計目使用電動工具將會導致危險。
5. 檢修
- a. 本電動工具必須由合格的維修人員並只採用相同的替換零件來執行檢修。這將確保電動工具的安全性。

切斷機之附加安全指示

- 請始終佩戴正當的護目鏡以及呼吸保護裝置。
- 請在使用前檢查切削砂輪是否已出現裂紋或裂縫。若發現有明顯的裂紋或裂縫，請棄置砂輪。若您認為工具有可能曾摔到地上過，也應該檢查切削砂輪。諸如此類的缺陷將導致砂輪斷裂。
- 啟動工具時，若您使用的是全新的或替換的砂輪，或者您不清楚砂輪的工作狀況，請將工具移至一個安全、保護完善的區域，讓它運行一分鐘。如果砂輪上有任何您未曾察覺過的裂紋或裂縫，砂輪必將在一分鐘內爆裂。啟動工具時，請不要將砂輪對著任何人，包括操作人員。
- 操作時，避免砂輪跳動或粗暴操作。如果出現跳動，請停止工作，然後檢查是否有任何裂紋或裂縫。
- 定期遵照本手冊中的程序清潔您的切斷機。
- 不要移除砂輪防護罩及底座。
- 始終使用夾具或特殊固定物將工件夾緊。其他如彈簧、條或 C 型萬力夾等的輔助工具可能會適用於夾緊特定大小和形狀的工件。選擇和置放這些夾具的時，請務必小心，進行切鋸前，先練習一遍。
- 僅可使用 14" 的 1 號砂輪，額定速度為 4100 轉/分或以上。
- 請等待切斷的部件冷卻後才觸碰。
- 請勿試圖使用本工具來切鋸木材或塑膠。
- 請勿使用本工具來切割鎂質材料。
- 請在通風良好的場地使用本切斷機。
- 從底座移除任何材料前，請將切斷機關掉。
- 請勿切割帶電材料。
- 請勿將本工具與圓鋸機鋸片或任何其他帶齒鋸片一起使用。那麼做可能會導致嚴重傷害。

- 請勿在易燃液體、氣體或塵埃附近操作工具。切割或電弧電動機電刷所產生的火花或熱碎片可能會引燃易燃材料。
- 請勿把砂輪切片的側面當作去毛刺研磨器使用。這將快速磨損您的砂輪片，導致危險，讓砂輪有可能斷裂！
- ⚠️ **小心：操作時請佩戴合適的聽力保護裝置。** 在某些使用情況下，使用了一定時間後，產品所產生的噪音將有可能讓您的聽力受損。
- ⚠️ **小心：火花偏導體會發熱。** 避免在這個時候觸碰到它，或對它進行調整。讓電線和材料遠離火花偏導體。
- 避免與專業砂光、切鋸、打磨、鑽孔以及其他建造操作所導致的粉塵長時間接觸。身穿防護服，用肥皂和水將所接觸到的區域清洗乾淨。別讓粉塵進入或接觸到您的嘴巴、眼睛或皮膚！您的身體可能會吸收到有害的化學物質。
- ⚠️ **警告：始終使用 NIOSH/OSHA 認可的呼吸保護裝置，適當保護自己對粉塵的接觸。** 請將粉塵導向的地方，遠離身體和臉部。為了您的安全及方便，您的重型 14" (355mm) 切斷機上包含了以下警告：
- ⚠️ **為確保安全操作，請仔細閱讀使用手冊。**
- 請勿使用帶齒鋸片。
- 請僅使用額定速度為 4100 轉/分或以上的加強砂輪。
- 檢修時，僅可使用相同的替換部件。
- 始終：佩戴護目鏡、使用防護罩、用夾具夾緊工件，佩戴正當的呼吸保護裝置。
- 不得將工具暴露在雨中或在潮濕環境中使用。
- 請僅使用最大厚度為 2.8mm、最大直徑必須為 355mm 的切斷機砂輪。

警告符號

您的工具上可能包含下列符號：

- ⦿ 佩戴護目鏡
- ⦿ 佩戴聽力保護裝置
- V 伏特
- A 安培
- Hz 赫茲
- W 瓦特
- min 分鐘
- ~ 交流電
- 直流電
- n₀ 空載轉速
- II 級結構

- ⊕接地終端
- ⚠安全警告符號
- .../min每分鐘旋轉或鋸切數

電氣安全

⚠ 警告！若電源線已損壞，您必須尋求製造廠商或 Stanley 授權檢修中心的幫助以進行更換，或讓類似的合格人員更換，避免可能的損壞以及傷害。但如果您的電源線由非 Stanley 所授權的類似合格人員所更換，則保固將無效。

功能部件 (圖 1 和 4)

- A. 鎖定開關
- B. 火花偏導器螺絲
- C. 火花偏導器
- D. 底座
- E. 擋板
- F. 夾具
- G. 扁平型扳手
- H. 曲柄
- I. 夾具水平支架
- J. 砂輪
- K. 防護罩
- L. 主軸鎖
- M. 限深器螺栓以及防鬆螺母
- N. 觸發開關
- O. 掛鎖孔
- P. 擋板螺栓
- X. 鎖銷

電源

確保您的電源與銘牌上標注的一致。電壓降低超過 10% 將導致功率損失以及過熱。

切割能力





本工具有更高的樞軸點、更大的夾具開口，讓它能夠輕易切割許多大型工件。請參閱切割能力圖表，確定新砂輪能切割的工件的最大總尺寸。

⚠ 小心：形狀不規則的物體，則可能會需要動用更多的夾具。

⚠ 小心：不要使用本工具來切割鎂質材料。

最大切割能力

注：圖表所示的切割能力假定砂輪無磨損，且擋板處於最佳位置。

工件形狀：				
90° 切割角度	A = 4-7/8" (125mm)	A = 4-1/2" (115mm)	4-1/2" x 5-1/8" (115mm x 130mm) 4" x 7-5/8" (102mm x 188mm) 3" x 7-3/8" (76mm x 229mm)	A = 4-1/2" x 5-3/8" (115mm x 137mm)
45° 切割角度	A = 4-1/2" (115mm)	A = 3-13/16" (98mm)	4-1/2" x 3-13/16" 4-1/8" x 3-3/4" (105mm x 95mm)	A = 3-13/16" 3-3/4" (95mm)

使用

標準裝置

- 355mm 金屬切割片
- 1 把砂輪扳手
- 1 本使用手冊

搬運 (圖 1)

將您的裝置折疊至一個可讓您搬運電鋸的程度。推入鎖銷 (X) 以鎖定電動機移動臂。

解鎖 (圖 1)

要為本工具解鎖並拉高鋸頭，請輕輕按下電動機移動臂並將鎖銷 (X) 往外拉，電動機移動臂將向上轉動。

調整火花偏導器 (圖 1)

要將火花偏導至別的地方，避免它濺到周圍人員和材料，請擰鬆螺絲 (B)，調整火花偏導器 (C)，然後再擰緊螺絲。不要讓電源線接觸到火花偏導器或火花，這可能會損壞電源線。

限深器螺栓 (圖 1)

限深器螺栓專為全新的 14" 砂輪而設定，其用途是避免砂輪切入支撐表面。為了增加工具的切割深度，請使用所提供的扁平型扳手 (G) 來鬆開限深器螺栓 (M)，並將螺栓提升至所需高度，然後順時針轉動防鬆螺母 (M) 直到其緊緊固定於鑄件上。使用前，請穩固擰緊限深器螺栓。

⚠ 小心：更換新砂輪時，請將限深器螺栓調整至原始位置，避免它切入支撐表面。

觸發開關 (圖 1)

若要啟動工具，請按下觸發開關 (N)。若要把工具關掉，請鬆開觸發開關。讓手和材料遠離砂輪，直至其停止運轉。為避免有人非授權使用工具，請在觸發開關上的掛鎖孔 (O) 中裝上一個標準掛鎖。

夾緊並支撐材料

- 用兩個支腳抵住工具底座，即可最好支撐工件進行斜角切割。
- 可使用比工件稍窄的墊塊，以增加砂輪利用率 (圖 2)。
- 長工件必須由墊塊支撐，好讓它能夠與底座的頂部呈水平線 (圖 3)。工件的切斷端必須能夠自由向下掉落，避免導致砂輪卡住。

夾具操作 (圖 4)

夾具 (F) 擁有一個快速移動功能。要鬆開緊夾的夾具，請逆時針轉動曲柄 (H) 一圈至四圈，去除夾緊壓力。將夾具水平支架 (I) 提起。拉出曲柄裝配，直至所需位置。無需使用曲柄即可將夾具推入工件中。降下夾具水平支架 (I)，再利用曲柄 (H) 將夾具 (F) 擰緊到位。

擋板操作 (圖 5 和 6)

⚠ 小心：調整、卸下或安裝附件或配件之前，必須先關閉工具的電源並拔下插頭。請確保觸發開關處於關閉 (OFF) 位置。可以通過兩種方法調整擋板 (E)：改變所需切割角度，以及改變擋板和夾具之間的距離。

改變所需切割角度

利用所提供的扳手鬆開兩個擋板螺栓 (P) (但請不要拆下)。將所需的角度指示線與底座 (D) 上的槽線 (A) 對齊。使用前，請牢固擰緊這兩個擋板螺栓。若要進行更加精確的方形切割，請關掉電源，擰鬆兩個擋板螺栓，並將移動臂往下推，直至砂輪碰到底座為止。將一塊方形緊貼砂輪，並根據這個方形調整擋板。使用前，請牢固擰緊這兩個擋板螺栓。根據不同工件的厚度和斜口切角度而論，夾具 (F) 有可能在您進行斜口切時無法牢固夾緊您的工件。因此，在進行這類切割時，可能會需要利用一些其他的輔助工具 (如彈簧、條或 C 型萬力夾) 來將工件固定到擋板上。

改變擋板和夾具之間的距離

利用所提供的扳手鬆開兩個擋板螺栓 (P)。將擋板 (E) 調整至所需位置。將擋板螺栓插入所提供的位

置。使用前，請牢固擰緊這兩個擋板螺栓。

拆下與安裝砂輪 (圖 7 和 8)

⚠ 小心：調整、卸下或安裝附件或配件之前，必須先關閉工具的電源並拔下插頭。請確保觸發開關處於關閉 (OFF) 位置。請不要在砂輪還在轉動的當兒作出任何調整。請不要在切斷機電源還接通的時候作出任何調整。

1. 將主軸鎖 (L) 推入，用手轉動砂輪 (J)，直至砂輪的鎖桿與內法蘭接合 (R)，鎖定砂輪。利用 8mm 六角扳手，將砂輪切片 (G) 中間的螺栓 (S) 逆時針轉動以將其擰松。此螺栓採用右旋螺紋。
2. 拆下螺栓 (S)、墊圈 (T)、外法蘭 (U) 以及舊砂輪 (J)。
3. 確保法蘭表面乾淨、平滑。
4. 不要將螺栓擰得過緊。

⚠ 警告：進行砂輪切片更換時，請檢查切斷機所停放的工作表面。當移動臂被完全降下時，砂輪切片有可能會接觸到/切入任何處於底座下、工作表面之上的物件或結構！

更精確的切割，操作提示

- 讓砂輪自動切割。過度使用體力將拋光砂輪的表面，進而降低其切割效率並/或導致砂輪彎曲，造成切割不準確。
- 適當調整擋板角度。
- 確保材料平躺於底座上。
- 適當夾緊材料，以避免移動和震動。

檢查和更換電動機電刷 (圖 9)

⚠ 警告：請關閉電源並拔下工具的插頭。請確保觸發開關處於關閉 (OFF) 位置。

應定期檢查電刷是否出現磨損。要檢查電刷，請擰鬆兩個端蓋螺絲 (V)，然後拆下端蓋 (W)。拆下電刷蓋 (Y)。電刷 (X) 應能夠在電刷盒中自由滑動。如果電刷如圖 9 所示，已磨損至 0.3" (8mm)，則應對其進行更換。要重新安裝，請將電刷推回電刷盒中。要更換現有電刷，請在移除時維持相同的方向。更換電刷蓋 (不要過度擰緊)。更換端蓋以及兩個螺絲。牢固擰緊。

維護

Stanley 電動工具採用卓越的設計，能夠長時間使用，並且只需最少的維護。若要持續獲得滿意的操作效果，需進行正確的工具維護和定期的清潔。

本工具不是使用者可檢修的裝置。請將工具送往 Stanley 授權維修中心。本工具應該定期檢修，或在效能出現顯著改變時進行檢修。

潤滑

Stanley 電動工具在原廠進行過適當的潤滑，可隨即使用。請定期潤滑工具，並根據使用率決定所需頻密度。只應由訓練有素的電動工具維修人員進行潤滑，例如 Stanley 授權檢修中心的維修人員，或其他合格的檢修人員。

全機器使用了潤滑脂密封球面滾子軸承。這些滾子軸承在原廠已經過足夠潤滑，可以在切斷機的整個工作壽命期間持續使用。

清潔

△ 警告：使用軟布清潔外殼前，請先關閉工具電源並拔掉插頭。每週至少一次，在電動機運行的同時，使用乾燥的空氣吹掉所有通風口內的塵埃和灰塵。進行此操作時請佩戴護目眼鏡。您可以使用蘸上溫和洗滌劑的濕布清潔外部的塑膠部件。雖然這些部件都具有很高的抗溶性，但請勿使用溶劑型洗滌劑！

一旦通風口及其周圍積聚可見的塵埃，請立即使用空氣管吹掉主機外殼內的塵埃和砂礫。請始終佩戴正當的護目鏡以及呼吸保護裝置。

工具保養

避免過載您的機器。過載將顯著降低運作速度和效率，並導致裝置變燙。在此情況下，請空載運行機器一至兩分鐘，直到內建風扇將機器冷卻至正常工作溫度為止。在過載情況下開關您的機器將顯著降低開關的工作壽命。

重要資訊

為了確保產品安全及可靠，所有的維修、維護和調整（除了本手冊中列出的之外），都應該由授權的檢修中心或合格機構執行，並始終使用相同的替換部件。本裝置內不含使用者可檢修的部件。一旦通風口及其周圍積聚可見的塵埃，請立即使用空氣管吹掉主機外殼內的塵埃和砂礫。請始終佩戴正當的護目鏡以及呼吸保護裝置。

注：本裝置可在授權檢修中心改裝成 3 線引掛式電纜裝置。

配件

任何電動工具的效能都取決於所使用的配件。Stanley 配件依據高品質標準進行規劃，並設計用於增強電動工具的效能。

注：配件的額定速度必須至少相等於或高於電動工具上所標示的轉/分。

△ 小心：使用任何不建議與本工具配合使用的其他配件會導致危險。僅可使用有機粘合的高強度 1 號砂輪，額定速度必須為 4100 轉/分或以上。只需支付額外費用，您就可以通過當地代理商或授權檢修中心獲取能與您的工具一起使用的推薦配件。

保護環境



若您發現您的產品需要進行替換，或您已經不再需要使用這些產品，請顧及環保。Stanley 建議您與當地理事會聯繫，獲得有關產品處置相關的資訊。

檢修資訊

Stanley 提供覆蓋整個亞洲的公司隸屬和授權檢修地點。所有的 Stanley 檢修中心都具有訓練有素的人員，為客戶提供高效可靠的電動工具檢修服務。不論您需要技術建議、維修或原廠替換部件，請聯繫離您最近的 Stanley 地點。

注意

- Stanley 的政策是持續改善我們的產品，因此，我們保留隨時變更產品規格的權利，恕不另行通知。
- 標準裝置和配件可能會根據不同的國家而有所不同。
- 產品規格可能會根據不同的國家而有所不同。
- 並非所有的國家都將提供完整的產品系列。
- 如需各產品系列的供應情況，請聯絡您當地的 Stanley 代理商。

進口商: 永安實業股份有限公司

電話: 02-29994633

地址: 新北市三重區中山路286號1F