

STANLEY

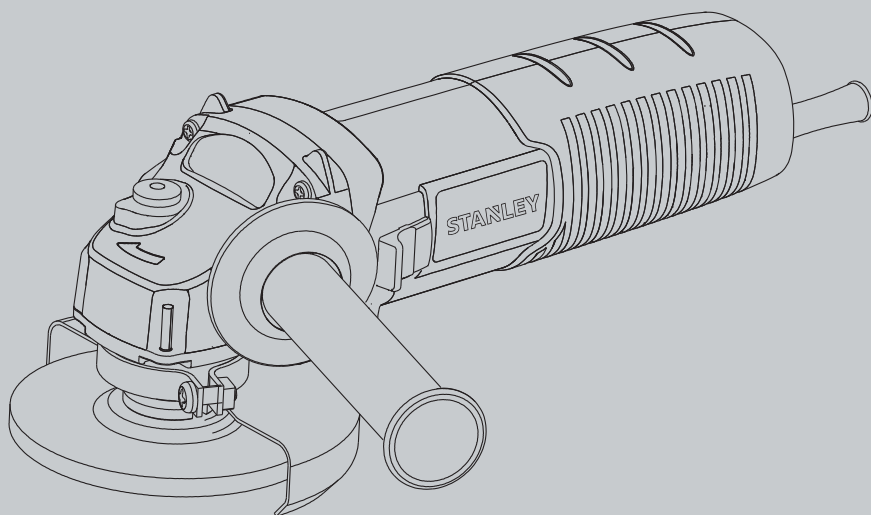

STGS7100
STGT7100

English(Original Instruction)
简体中文

5
13

Figure 1

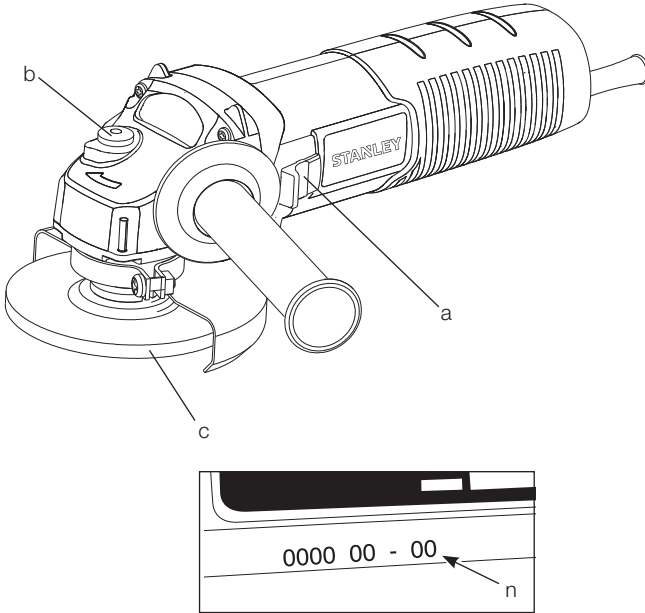

Figure 2

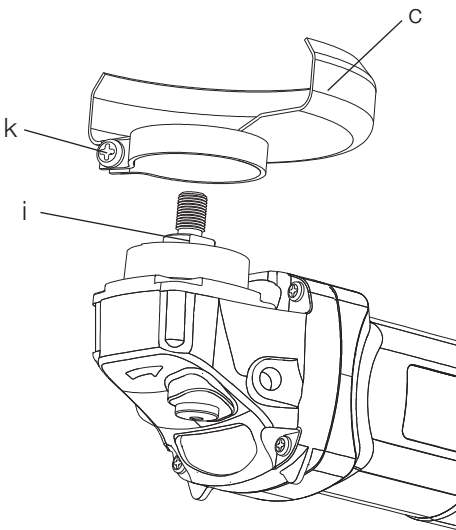

Figure 3

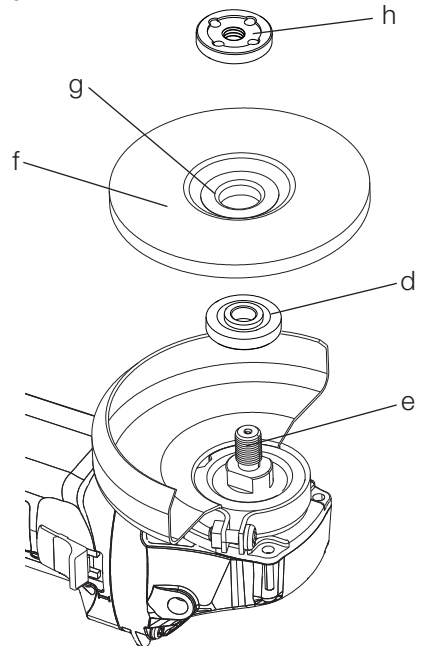

Figure 4

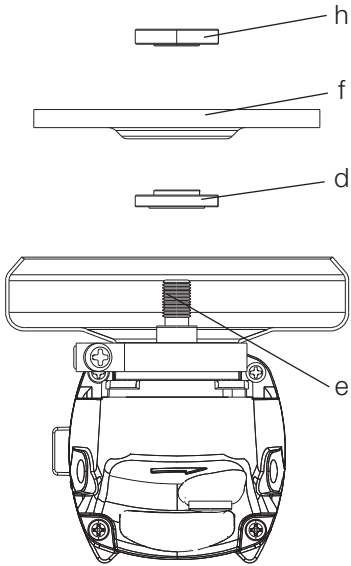

Figure 5

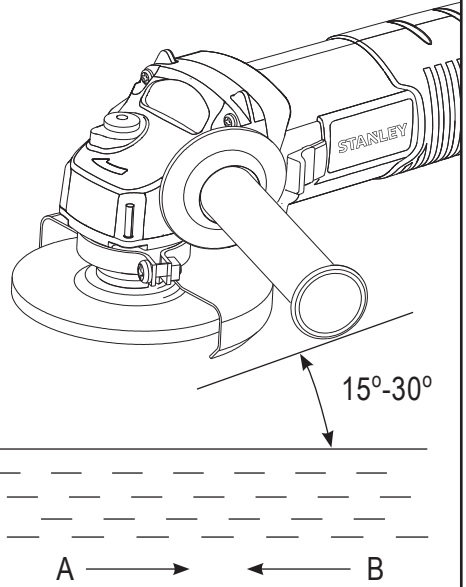

Figure 6

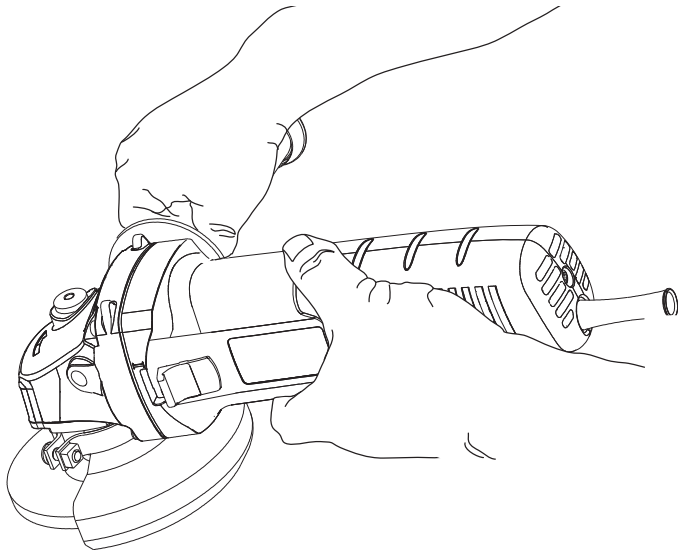
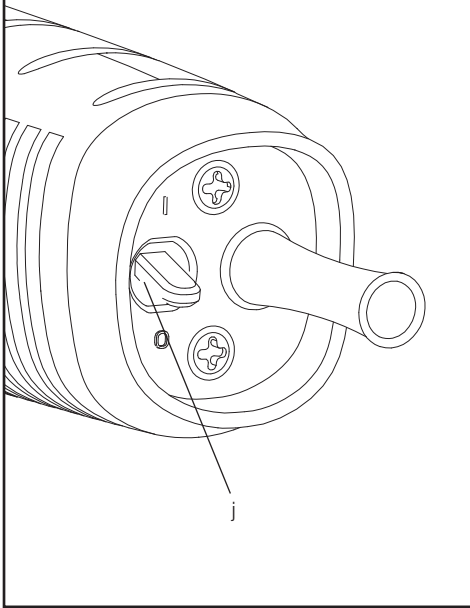

Figure 7



ANGLE GRINDERS

STGS7100/STGT7100

Technical Data

		STGS7100	STGT7100
Input power	W	710	710
No-load speed/rated speed	min ⁻¹	11,000	11,000
Wheel diameter	mm	100	100
Grinding wheels thickness	mm	6	6
Type of wheel		27	27
Spindle diameter		M10	M10
Weight	kg	1.8	1.8

Definitions: Safety Guidelines

The definitions below describe the level of severity for each signal word. Please read the manual and pay attention to these symbols.



DANGER: Indicates an imminently hazardous situation which, if not avoided, **will** result in **death or serious injury**.



WARNING: Indicates a potentially hazardous situation which, if not avoided, **could** result in **death or serious injury**.



CAUTION: Indicates a potentially hazardous situation which, if not avoided, **may** result in **minor or moderate injury**.

NOTICE: Indicates a practice **not related to personal injury** which, if not avoided, **may** result in **property damage**.



Denotes risk of electric shock.



Denotes risk of fire.



WARNING: To reduce the risk of injury, read the instruction manual.

General Power Tool Safety Warnings



WARNING! Read all safety warnings and all instructions. Failure to follow the warnings and instructions may result in electric shock, fire and/or serious injury.

SAVE ALL WARNINGS AND INSTRUCTIONS FOR FUTURE REFERENCE

The term “power tool” in the warnings refers to your mains-operated (corded) power tool or battery-operated (cordless) power tool.

1) WORK AREA SAFETY

- Keep work area clean and well lit.** Cluttered or dark areas invite accidents.
- Do not operate power tools in explosive atmospheres, such as in the presence of flammable liquids, gases or dust.** Power tools create sparks which may ignite the dust or fumes.
- Keep children and bystanders away while operating a power tool.** Distractions can cause you to lose control.

2) ELECTRICAL SAFETY

- Power tool plugs must match the outlet. Never modify the plug in any way. Do not use any adapter plugs with earthed (grounded) power tools.** Unmodified plugs and matching outlets will reduce risk of electric shock.
- Avoid body contact with earthed or grounded surfaces such as pipes, radiators, ranges and refrigerators.** There is an increased risk of electric shock if your body is earthed or grounded.
- Do not expose power tools to rain or wet conditions.** Water entering a power tool will increase the risk of electric shock.
- Do not abuse the cord. Never use the cord for carrying, pulling or unplugging the power tool. Keep cord away from heat, oil, sharp edges or moving parts.** Damaged or entangled cords increase the risk of electric shock.
- When operating a power tool outdoors, use an extension cord suitable for outdoor use.** Use of a cord suitable for outdoor use reduces the risk of electric shock.
- If operating a power tool in a damp location is unavoidable, use a residual current device (RCD) protected supply.** Use of an RCD reduces the risk of electric shock.

3) PERSONAL SAFETY

- Stay alert, watch what you are doing and use common sense when operating a power tool. Do not use a power tool while you are tired or under the influence of drugs, alcohol or medication.** A moment of inattention while operating power tools may result in serious personal injury.

- b) **Use personal protective equipment. Always wear eye protection.** Protective equipment such as dust mask, non-skid safety shoes, hard hat, or hearing protection used for appropriate conditions will reduce personal injuries.
 - c) **Prevent unintentional starting. Ensure the switch is in the off position before connecting to power source and/or battery pack, picking up or carrying the tool.** Carrying power tools with your finger on the switch or energising power tools that have the switch on invites accidents.
 - d) **Remove any adjusting key or wrench before turning the power tool on.** A wrench or a key left attached to a rotating part of the power tool may result in personal injury.
 - e) **Do not overreach. Keep proper footing and balance at all times.** This enables better control of the power tool in unexpected situations.
 - f) **Dress properly. Do not wear loose clothing or jewellery. Keep your hair, clothing and gloves away from moving parts.** Loose clothes, jewellery or long hair can be caught in moving parts.
 - g) **If devices are provided for the connection of dust extraction and collection facilities, ensure these are connected and properly used.** Use of dust collection can reduce dust-related hazards.
- e) **Maintain power tools. Check for misalignment or binding of moving parts, breakage of parts and any other condition that may affect the power tool's operation. If damaged, have the power tool repaired before use.** Many accidents are caused by poorly maintained power tools.
 - f) **Keep cutting tools sharp and clean.** Properly maintained cutting tools with sharp cutting edges are less likely to bind and are easier to control.
 - g) **Use the power tool, accessories and tool bits etc., in accordance with these instructions taking into account the working conditions and the work to be performed.** Use of the power tool for operations different from those intended could result in a hazardous situation.

5) SERVICE

- a) **Have your power tool serviced by a qualified repair person using only identical replacement parts.** This will ensure that the safety of the power tool is maintained.

ADDITIONAL SPECIFIC SAFETY RULES

Safety Instructions for All Operations

Safety Warnings common for Grinding

4) POWER TOOL USE AND CARE

- a) **Do not force the power tool. Use the correct power tool for your application.** The correct power tool will do the job better and safer at the rate for which it was designed.
- b) **Do not use the power tool if the switch does not turn it on and off.** Any power tool that cannot be controlled with the switch is dangerous and must be repaired.
- c) **Disconnect the plug from the power source and/or the battery pack from the power tool before making any adjustments, changing accessories, or storing power tools.** Such preventive safety measures reduce the risk of starting the power tool accidentally.
- d) **Store idle power tools out of the reach of children and do not allow persons unfamiliar with the power tool or these instructions to operate the power tool.** Power tools are dangerous in the hands of untrained users.
- a) **This power tool is intended to function as a grinder. Read all safety warnings, instructions, illustrations and specifications provided with this power tool.** Failure to follow all instructions listed below may result in electric shock, fire and/or serious injury.
- b) **Operations such as cutting-off, sander, wire brush or polisher are not recommended to be performed with this power tool.** Operations for which the power tool was not designed may create a hazard and cause personal injury.
- c) **Do not use accessories which are not specifically designed and recommended by the tool manufacturer.** Just because the accessory can be attached to your power tool, it does not assure safe operation.
- d) **The rated speed of the accessory must be at least equal to the maximum speed marked on the power tool.** Accessories running faster than their rated speed can break and fly apart.
- e) **The outside diameter and the thickness of your accessory must be within the capacity rating of your power tool.** Incorrectly sized accessories cannot be adequately guarded or

controlled.

- f) **The arbour size of wheels, flanges, backing pads or any other accessory must properly fit the spindle of the power tool.** Accessories with arbour holes that do not match the mounting hardware of the power tool will run out of balance, vibrate excessively and may cause loss of control.
- g) **Do not use a damaged accessory. Before each use inspect the accessory such as abrasive wheel for chips and cracks, backing pad for cracks, tear or excess wear, wire brush for loose or cracked wires. If power tool or accessory is dropped, inspect for damage or install an undamaged accessory. After inspecting and installing an accessory, position yourself and bystanders away from the plane of the rotating accessory and run the power tool at maximum no-load speed for one minute. Damaged accessories will normally break apart during this test time.**
- h) **Wear personal protective equipment. Depending on application, use face shield, safety goggles or safety glasses. As appropriate, wear dust mask, hearing protectors, gloves and workshop apron capable of stopping small abrasive or workpiece fragments.** The eye protection must be capable of stopping flying debris generated by various operations. The dust mask or respirator must be capable of filtering particles generated by your operation. Prolonged exposure to high intensity noise may cause hearing loss.
- i) **Keep bystanders a safe distance away from work area. Anyone entering the work area must wear personal protective equipment.** Fragments of workpiece or of a broken accessory may fly away and cause injury beyond immediate area of operation.
- j) **Hold the power tool by insulated gripping surfaces only, when performing an operation where the cutting accessory may contact hidden wiring or its own cord.** Cutting accessory contacting a "live" wire may make exposed metal parts of the power tool "live" and could give the operator an electric shock.
- k) **Position the cord clear of the spinning accessory.** If you lose control, the cord may be cut or snagged and your hand or arm may be pulled into the spinning accessory.
- l) **Never lay the power tool down until the accessory has come to a complete stop.** The spinning accessory may grab the surface and pull the power tool out of your control.

- m) **Do not run the power tool while carrying it at your side.** Accidental contact with the spinning accessory could snag your clothing, pulling the accessory into your body.
- n) **Regularly clean the power tool's air vents.** The motor's fan will draw the dust inside the housing and excessive accumulation of powdered metal may cause electrical hazards.
- o) **Do not operate the power tool near flammable materials.** Sparks could ignite these materials.
- p) **Do not use accessories that require liquid coolants.** Using water or other liquid coolants may result in electrocution or shock.

FURTHER SAFETY INSTRUCTIONS FOR ALL OPERATIONS

Kickback and Related Warnings

Kickback is a sudden reaction to a pinched or snagged rotating wheel, backing pad, brush or any other accessory. Pinching or snagging causes rapid stalling of the rotating accessory which in turn causes the uncontrolled power tool to be forced in the direction opposite of the accessory's rotation at the point of the binding.

For example, if an abrasive wheel is snagged or pinched by the workpiece, the edge of the wheel that is entering into the pinch point can dig into the surface of the material causing the wheel to climb out or kick out. The wheel may either jump toward or away from the operator, depending on direction of the wheel's movement at the point of pinching. Abrasive wheels may also break under these conditions.

Kickback is the result of tool misuse and/or incorrect operating procedures or conditions and can be avoided by taking proper precautions as given below:

- a) **Maintain a firm grip on the power tool and position your body and arm to allow you to resist kickback forces. Always use auxiliary handle, if provided, for maximum control over kickback or torque reaction during start up.** The operator can control torque reaction or kickback forces, if proper precautions are taken.
- b) **Never place your hand near the rotating accessory.** Accessory may kickback over your hand.
- c) **Do not position your body in the area where power tool will move if kickback occurs.** Kickback will propel the tool in direction opposite to the wheel's movement at the point

of snagging.

- d) **Use special care when working corners, sharp edges etc. Avoid bouncing and snagging the accessory.** Corners, sharp edges or bouncing have a tendency to snag the rotating accessory and cause loss of control or kickback.
- e) **Do not attach a saw chain woodcarving blade or toothed saw blade.** Such blades create frequent kickback and loss of control.

Safety Warnings Specific for Grinding Operations

- a) **Use only wheel types that are recommended for your power tool and the specific guard designed for the selected wheel.** Wheels for which the power tool was not designed cannot be adequately guarded and are unsafe.
- b) **The guard must be securely attached to the power tool and positioned for maximum safety, so the least amount of wheel is exposed towards the operator.** The guard helps to protect operator from broken wheel fragments and accidental contact with wheel and sparks that could ignite clothing.
- c) **Wheels must be used only for recommended applications. For example: do not grind with the side of cut-off wheel.** Abrasive cut-off wheels are intended for peripheral grinding, side forces applied to these wheels may cause them to shatter.
- d) **Always use undamaged wheel flanges that are of correct size and shape for your selected wheel.** Proper wheel flanges support the wheel thus reducing the possibility of wheel breakage. Flanges for cut-off wheels may be different from grinding wheel flanges.
- e) **Do not use worn down wheels from larger power tools.** Wheel intended for larger power tool is not suitable for the higher speed of a smaller tool and may burst.

Residual Risks

In spite of the application of the relevant safety regulations and the implementation of safety devices, certain residual risks cannot be avoided. These are:

- Impairment of hearing
- Risk of personal injury due flying particles.
- Risk of burns due to accessories becoming hot during operation.
- Risk of personal injury due to prolonged use.

- Risk of dust from hazardous substances.

Tool Symbols

The following symbols are printed on the tool:



Read the instruction manual before use.



Please wear hearing protectors.



Please wear eye protection equipment.

POSITION OF DATE BARCODE (FIG. 1)

The date barcode (n), including the year of manufacturing, is printed on the tool housing.

E.g.:

2015 XX JN

Year of manufacturing

Package Content

This product package includes:

- 1 Angle grinder
 - 1 Guard
 - 1 Flange set
 - 1 Spanner
 - 1 Handle (only apply for STGS7100/STGS6100)
 - 1 Instruction manual
- Check the tool, parts, and accessories to see if they are damaged during transportation.
 - Take a few moments to read and understand this manual before using the tool.

Description (Fig. 1)



WARNING: Never modify the power tool or any part of the tool, otherwise it may cause damage to the tool or result in personal injury.

- a. ON/OFF switch
- b. Spindle lock
- c. Guard

PURPOSE OF DESIGN

This angle grinder is designed especially for grinding.

Do not use sandpaper discs and grinding wheels other than those with depressed center.

Do not use the tool in wet conditions or environments in the presence of flammable liquids or gases.

This heavy-duty angle grinder is a professional power tool.

Do not allow children to come in contact with this tool. Inexperienced operators are required to use this tool under supervision.

Electrical Equipment Safety

Only one voltage is applicable to this tool. Be sure to check that the power supply corresponds to the voltage on the rating plate.



Your Stanley tool is equipped with double insulation, hence, it does not require to be earthed.

When the power cord is damaged, have it sent to a Stanley service center for replacement to specially prepared cables.

Using Extension Cords

If an extension cord is required, please select a 3-phase extension cord that has been inspected and matches the input power (see Technical Data) of this tool. The minimum conductor size is 1.5mm², maximum length is 30 meters.

When using a cable reel, be sure to pull out all the cables.

Assembly and Adjustment



WARNING: To minimize the danger of serious personal injury, please switch off the tool power and disconnect all plugs before adjusting or removing/ installing any accessory. Before reassembling the tool, press and release the trigger switch to make sure the tool is already switched off.

Attaching and Removing the Wheel Guard (Fig. 2)



WARNING: To minimize the danger of serious personal injury, please switch off the tool power and disconnect all plugs before adjusting or removing/ installing any accessory. Before reassembling the tool, press and release the trigger switch to make sure the tool is already switched off.

ATTACHING THE GUARD

1. Place the angle grinder on a work bench, groove facing up.
2. Bring the flange of the guard (c) collar over the groove (i) of the gear housing.
3. Turn the guard (c) counterclockwise by 150 degrees.
4. Make sure that the screws (k) are tightened.

REMOVING THE GUARD

1. Loosen the screws (k) on the guard collar.
2. Pull up the guard (c).



WARNING: Do not operate the tool when the safety guard is not in place.

Note: Refer to the **grinding accessories chart** at the end of this section for accessories that can be used together with this angle grinder.

Attaching and Removing Grinding Wheels (Fig. 3, 4)



WARNING: Do not use damaged grinding wheels.

1. Place the tool on a work bench, groove facing up.
2. Attach the inner flange (d) correctly on the output shaft (e) (Fig. 3).
3. Place the grinding wheel (f) on the inner flange (d). When attaching a grinding wheel with a raised center, make sure that the raised center (g) faces the inner flange (d).
4. Tighten the outer flange (h) until the output shaft (e) (Fig. 4). When attaching the grinding wheel, the ring on top of the outer flange (h) must face the wheel.
5. Press the spindle lock (b) and prevent the spindle (e) from rotating until it locks in place.
6. Use the pin spanner to tighten the outer flange (h).

Preparation Before Use

- Attach the safety guard and appropriate abrasive or grinding wheels. Do not use abrasive or grinding wheels that are overly worn.
- Make sure that the inner and outer flanges are attached correctly.
- Make sure that the abrasive or grinding wheels are rotating in the direction of the arrows on the accessories and tool.

Operation (Fig. 5)

Instructions



WARNING: Always observe the safety instructions and applicable regulations.



WARNING: To minimize the danger of serious personal injury, please switch off the tool power and disconnect all plugs before adjusting or removing/installing any accessory. Before reassembling the tool, press and release the trigger switch to make sure the tool is already switched off.



WARNING:

- Make sure all materials to be grinded are secured in position.
- Apply slight pressure to the tool. Do not apply side pressure to the abrasive disc.
- Avoid overloading. If the tool becomes hot, let it spin for a few minutes with no load.

1. Be sure to hold the tool tightly with both hands (one hand on housing, the other on side handle). Start the tool and bring the grinding wheel on the workpiece.
2. Keep the edge of the wheel tilted at angle from 15 to 30 degrees against the surface of the workpiece.
3. When using a new grinding wheel, do not operate the wheel in the B direction, otherwise, it will cut into the workpiece. When the edge of wheel has been rounded off, you are free to operate the grinder in either the A or B direction.

Starting and Stopping (Fig. 1)



WARNING: Before using the tool, check whether the handle is tightened securely. Check whether the ON/OFF switch is working normally.

Before plugging in the tool to the power supply, check whether the switch is in the OFF (o) position when pressing the rear end of the switch.

Slider switch (STGS6100/7100)

Before plugging in the tool to the power supply, check whether the switch is in the OFF (a) position when pressing the rear end of the switch.

To start the tool, press the rear end of the switch and slide it forward. Then press the front end of the

switch to lock it. Press the rear end of the switch to stop the tool.

Toggle switch (STGT6100/7100)

To run the tool, press the switch (j) in before moving it completely forward.

To stop the tool, move the switch (j) back the opposite way.

to stop the tool in continuous operation, press on back part of the switch.



WARNING: Do not switch the tool on or off while under load conditions.



WARNING: Do not switch the tool on or off while under load conditions.

Switches



CAUTION: Hold the body of the tool firmly to maintain control of the tool at start up and during use and until the wheel or accessory stops rotating. Make sure the wheel has come to a complete stop before laying the tool down.

NOTE: To reduce unexpected tool movement, do not switch the tool on or off while under load conditions. Allow the grinder to run up to full speed before touching the work surface. Lift the tool from the surface before turning the tool off. Allow the tool to stop rotating before putting it down.

SLIDER SWITCH (STGS7100/STGS6100)



WARNING: Before connecting the tool to a power supply, be sure the slider switch is in the off position by pressing the rear part of the switch and releasing. Ensure the slider switch is in the off position as described above after any interruption in power supply to the tool, such as the activation of a ground fault interrupter, throwing of a circuit breaker, accidental unplugging, or power failure. If the slider switch is locked on when the power is connected, the tool will start unexpectedly.

To start the tool, slide the slider switch (a) toward the front of the tool.

To stop the tool, release the slider switch. For continuous operation, slide the switch toward the front of the tool and press the forward part of the switch inward.

To stop the tool while operating in continuous mode, press the rear part of the slider switch and release.

TOGGLE SWITCH (STGT7100/STGT6100)



WARNING: Before connecting the tool to a power supply, be sure the toggle switch is in the off (0) position by pressing the rear part of the switch and releasing. Ensure the toggle switch is in the off position as described above after any interruption in power supply to the tool, such as the activation of a ground fault interrupter, throwing of a circuit breaker, accidental unplugging, or power failure. If the toggle switch is locked on when the power is connected, the tool will start unexpectedly.

To start the tool, move the switch (j) completely forward to "1" position. To stop the tool, move the switch (j) back the opposite "0" position. To run the tool in continuous operation, keep the switch (j) on "1" position. To stop the tool in continuous operation, move the switch (j) back the opposite "0" position.

Proper Hand Position (Fig. 6)



WARNING: To reduce the risk of serious personal injury, **ALWAYS** use proper hand position as shown.



WARNING: To reduce the risk of serious personal injury, **ALWAYS** hold securely in anticipation of a sudden reaction.

Proper hand position requires one hand on the side handle (figure 1), with the other hand on the body of the tool, as shown in figure 6.

Spindle lock (Fig. 1)

The spindle lock (b) prevents the output shaft from rotating when attaching or removing the grinding wheel. Only use the spindle lock when the tool is switched off, power is unplugged, and wheel stops completely.



NOTE: To minimize tool damages, don't use the spindle lock when the tool is operating. Otherwise, it may damage the tool. The attached accessories may come off and cause injury.

If using the spindle lock, press the spindle lock button and rotate the output shaft until it stops.

Application on Metals

When applying the tool on metals, make sure that a residual-current device (RCD) is inserted to prevent danger from metal chips.

If the RCD causes power disconnection, have the tool sent to an authorized Stanley dealer for repair.



WARNING: Under extreme working conditions, conductive dust and grit may accumulate on the housing interior when handling metal workpieces. This could create an electric shock hazard as it weakens the protective insulation in the grinder.

To avoid accumulation of metal chips in the interior of the grinder, we recommend cleaning the ventilation ducts daily. Refer to **Maintenance**.

Using Grinding Wheels



WARNING: Metal powder accumulates. Excessive use of the grinding wheel on metals may increase the risk of electric shock. To reduce the risk, insert the RCD before use and clean the ventilation ducts daily. Follow the maintenance instructions below to blow dry compressed air into the ventilation ducts.

Maintenance

Stanley power tools have been designed to operate over a long period of time with minimal maintenance. Continuous satisfactory operation depends upon proper tool care and regular cleaning.



WARNING: To minimize the danger of serious personal injury, please switch off the tool power and disconnect all plugs before adjusting or removing/installing any accessory. Before reassembling the tool, press and release the trigger switch to make sure the tool is already switched off.



Lubrication

This power tool does not require separate lubrication.



Cleaning



WARNING: Once visible dust accumulates on the ventilation ducts and the surrounding, immediately use dry air to blow away dust and grit out of the interior of the housing. You need to wear approved eye and facial protective gear when performing this process.



WARNING: Never use solvents or harsh chemicals to clean non-metal parts of the tool. These chemicals may weaken the material of the parts. Use only mild soap and damp cloth to clean the tool. Never let any liquid get inside the tool; never immerse any part of the tool into liquid.

- Product specifications may differ by country.
- Complete product range may not be available in all countries. Contact your local Stanley dealers for range availability.

Accessories



WARNING: Excluding accessories provided by Stanley, all other accessories have not been tested for product compatibility. Using such accessories together with this tool may cause safety hazards. To minimize the risk of personal injury, we recommend you to use only Stanley accessories with this product.

Please inquire at your dealer for more information regarding suitable accessories.

Protecting The Environment



Sorting and Recycling. This product is not to be disposed of with normal household waste.

In the event that you need to replace your Stanley product or if it is of no further use to you, please do not dispose of it together with household waste. Please sort it out for separate recycling.



Sorting out and recycling used products and packaging ensure usable materials are recycled and reused. Reusing reusable materials helps to prevent environmental pollution and reduce the demand for raw materials.

Regulations may stipulate your local city council and new product retailers to provide waste disposal centers or electrical product recycling service.

Stanley provides collection and recycling of end-of-life products. To enjoy this service, please have the product sent back to any authorized dealer for recycling.

Remarks

- Stanley's policy is one of continuous improvement to our products and as such, we reserve the right to modify product specifications without prior notice.
- Standard equipment and accessories may vary by country.

角向磨光机

STGS7100/STGT7100

技术参数

型号		STGS7100	STGT7100
输入功率	瓦	710	710
空载转速 /			
额定转速	次 / 分	11,000	11,000
砂轮片直径	毫米	100	100
磨削砂轮片厚度	毫米	6	6
砂轮片孔径	毫米	27	27
主轴螺纹		M10	M10
重量	千克	1.8	1.8

定义：安全指引

下列定义描述了各警示词的严重程度。请仔细阅读本手册，并注意这些警示符号。



危险：表示紧急危险情况，如果不加以避免，将导致死亡或严重伤害。



警告：表示存在潜在的危险情况，如果不加以避免，可能导致死亡或严重伤害。



警示：表示存在潜在危险情况，如果不加以避免，可能导致轻度或中度伤害。

注意：表示存在不涉及人身伤害的情况，如果不加以避免，可能导致财产损失。



表示存在触电危险。



表示存在火灾风险。



警告：为降低伤害风险，请阅读使用手册。

一般安全规则



警告！阅读说明 没有按照以下列举的说明而使用或操作将导致触电、着火

和/或严重伤害。在所有以下列举的警告中术语“电动工具”指市电驱动（有线）电动工具或电池驱动（无线）电动工具。

保存这些说明

a) 工作场地

- 1) 保持工作场地清洁和明亮。混乱和黑暗的场地会引发事故。
- 2) 不要在易爆环境，如有易燃液体、气体或粉尘的环境下操作电动工具。电动工具产生的火花会点燃粉尘或气体。
- 3) 让儿童和旁观者离开后操作电动工具。分心会使你放松控制。

b) 电气安全

- 1) 电动工具插头必须与插座相配。绝不能以任何方式改装插头。需接地的电动工具不能使用任何转换插头。未经改装的插头和相配的插座将减少触电危险。
- 2) 避免人体接触接地表面，如管道、散热片和冰箱。如果你身体接地会增加电击危险。
- 3) 不得将电动工具暴露在雨中或潮湿环境中。水进入电动工具将增加电击危险。
- 4) 不得滥用电线。绝不能用电线搬运、拉动电动工具或拨出其插头。让电动工具远离热、油、锐边或运动部件。受损或缠绕的电线会增加触电危险。
- 5) 当在户外使用电动工具时，使用适合户外使用的外接软线。适合户外使用的软线将减少电击危险。

c) 人身安全

- 1) 保持警觉，当操作电动工具时关注所从事的操作并保持清醒。切勿在有疲倦、药物、酒精或治疗反应下操作电动工具。在操作电动工具期间精力分散会导致严重人身伤害。
- 2) 使用安全装置。始终配戴护目镜。安全装置，诸如适当条件下的防尘面具、防滑安全鞋、安全帽、听力防护等装置能减少人身伤害。

- 3) 避免突然起动。确保开关在插入插头时处于关断位置。手指放在已接能电源的开关上或开关处于接通时插入插头可能会导致危险。
 - 4) 在电动工具接通之前, 拿掉所有调节钥匙或扳手。遗留在电动工具旋转零件上的扳手或钥匙会导致人身伤害。
 - 5) 手不要伸展得太长。时刻注意立足点和身体平衡。这样在意外情况下能很好地控制电动工具。
 - 6) 着装适当。不要穿宽松衣服或佩带饰品。让你的头发、衣服和袖子远离运动部件。宽松衣服、佩饰或长发可能会卷入运动部件中。
 - 7) 如果提供了与排屑装置、集尘设备连接的装置, 则确保他们连接完好且使用得当。使用这些装置可减少尘屑引起的危险。
- d) 电动工具使用和注意事项
- 1) 不要滥用电动工具, 根据用途使用适当的电动工具。选用适当的设计额定值的电动工具会使你工作更有效、更安全。
 - 2) 如果开关不能接通或关断工具电源, 则不能使用该电动工具。不能用开关来控制的电动工具是危险的且必须进行修理。
 - 3) 在进行任何调节、更换附件或贮存电动工具之前, 必须从电源上拔掉插头和/或将电池盒脱开电源。这种防护性措施将减少电动工具突然起动的危险。
 - 4) 将闲置电动工具贮存在儿童所及范围之外, 并且不要让不熟悉电动工具或对这些说明不了解的人操作电动工具。电动工具在未经训练的用户手中的是危险的。
 - 5) 保养电动工具。检查运动件的安装偏差或卡住、零件破损情况和影响电动工具运行的其他条件。如有损坏, 电动工具必须在使用前修理好。许多事故由维护不良的电动工具引发。
 - 6) 保持切削刀具锋利和清洁。保养良好的有锋利切削刃的刀具不易卡住而且容易控制。
 - 7) 按照使用说明书以及打算使用的电动工具的特殊类型要求的方式, 考虑作业条件和进行

的作业来使用电动工具、附加和工具的刀头等。将电动工具用作那些与要求不符的操作可能会导致危险情况。

e) 维修

- a) 将你的电动工具送交专业维修人员, 必须使用同样的备件进行更换。这样将确保所维修的电动工具的安全性。

所有操作的使用说明

研磨操作的通用安全警告

- a) 该电动工具是用于实现砂轮机功能的。阅读随该电动工具提供的所有安全警告、说明、图解和规定。不了解以下所列所有说明将导致电击、着火和/或严重伤害。
- b) 不推荐用该电动工具进行诸如砂光、刷光、抛光或切割等操作。电动工具不按指定的功能去操作, 可能会发生危险和引起人身伤害。
- c) 不可使用非工具制造商推荐和专门设计的附件。否则该附件可能被装到你的电动工具上, 而它不能安全操作。
- d) 附件的额定转速必须至少等于电动工具上标出的最大速度。附件以比其额定转速大的速度运转会发生爆裂和飞溅。
- e) 附件的外径和厚度必须在电动工具额定能力范围内。不正确的附件尺寸不能得到充分保护或控制。
- f) 砂轮、法兰盘、靠背垫或任何其他附件的轴孔尺寸必须适合于安装到电动工具的主轴上。带轴孔、与电动工具安装件不配的附件将会失稳、过度振动并会引起失控。
- g) 不要使用损坏的附件。在每次使用前要检查附件, 例如砂轮是否有碎片和裂缝, 靠背垫是否有裂缝、撕裂或过度磨损, 钢丝刷是否松动或金属丝是否断裂。如果电动工具或附件跌落了, 检查是否有损坏或安装没有损坏的附件。检查和安装附件后, 让自己和旁观者的位置远离旋转附件的平面, 并以电动工具最大空载转速运

- 行 1min。破损的附件通常在该试验时会碎裂。
- h) 戴上防护用品。根据适用情况，使用面罩、安全护目镜或安全眼镜。适用时，戴上防尘面具、听力保护器、手套和能挡小磨料或工件碎片的工作围裙。眼防护罩必须挡住各种操作产生的飞屑。防尘面具或口罩必须能够过滤操作产生的颗粒。长期暴露在高强度噪声中会引起失聪。
- i) 让旁观者与工作区域保持一定安全距离。任何进入工作区域的人必须戴上防护用品。工件或破损附件的碎片可能会飞出并引起紧靠着操作区域的旁观者的伤害。切割附件触及带电导线会使电动工具外漏的金属零件带电，并使操作者触电。
- j) 当在切割附件有可能切割到暗线或自身电线的场所进行操作时，只能通过绝缘握持面来握住电动工具。切割附件碰到一根带电导线会使电动工具外露金属零件带电并使操作者发生电击危险。
- k) 使软线远离旋转的附件。如如果控制不当，软线可能被切断或缠绕，并使得你的手或手臂可能被卷入旋转附件中。
- l) 直到附件完全停止运动才放下电动工具。旋转的附件可能会抓住表面并拉动电动工具而让你失去对工具的控制。
- m) 当携带电动工具时不要开动它。意外地触及旋转附件可能会缠绕你的衣服而使附件伤害身体。
- n) 经常清理电动工具的通风口。电动机风扇会将灰尘吸进机壳，过多的金属粉尘沉积会导致电气危险。
- o) 不要在易燃材料附近操作电动工具。火星可能会点燃这些材料。
- p) 不要使用需要冷却液的附件。用水或其他冷却液可能会导致触电或触电死亡。

所有操作的进一步安全指示

反弹和相关警告

反弹是因卡住或缠绕住的旋转砂轮、靠背垫、钢丝

刷或其他附件而产生的突然反作用力。卡住或缠绕会引起转动附件的迅速堵转，随之使失控的电动工具在卡住点产生与附件旋转方向相反的运动。

例如，如果砂轮被工件缠绕或卡住，伸入卡住点的砂轮边缘可能会进入材料表面而引起砂轮爬出或反弹。砂轮可能会飞向或飞离操作者，这取决于砂轮在卡住点的运动方向。在此条件下砂轮也可能会碎裂。

反弹是电动工具误用和 / 或不正确的操作工序或条件的结果。可以通过采取以下给出的适当预防措施得以避免。

- a) 保持紧握电动工具，使您的身体和手臂处于正确状态以抵抗反弹力。如有辅助手柄，则要一直使用，以便最大限度地控制启动时的反弹力或反力矩。如果采取合适的预防措施，操作员就可以控制反力矩或反弹力。
- b) 绝不能将手靠近转动附件。附件可能会反弹碰到手。
- c) 不要站在发生反弹时电动工具可能移动到的位置。反弹将在缠绕点驱使工具逆砂轮片运动方向运动。
- d) 当在尖角、锐边等处作业时要特别小心。避免附件的弹跳和缠绕。尖角、锐边和弹跳具有缠绕旋转附件的趋势并引起反弹的失控。
- e) 不要附装上锯链、木雕刀片或带齿锯片。这些锯片会产生频繁的反弹和失控。

砂磨和切割操作的附件安全说明

对砂磨操作的专用安全警告

- a) 只使用所推荐的砂轮型号和为选用砂轮专门设

计的护罩。不是为电动工具设计的砂轮不能充分得到保护，是不安全的。

- b) 护罩必须牢固地装在电动工具上，且放置得最具安全性，只有最小的砂轮部分暴露在操作人面前。护罩帮助保护操作者免于受到爆裂砂轮碎片和偶然触及砂轮的危險。
- c) 砂轮只用作推荐的用途。例如：不要用切割砂轮的侧面进行磨削。施加到砂轮侧面的力可能会使其碎裂。
- d) 始终为所选砂轮选用未损坏的、有恰当规格和形状的砂轮法兰盘。合适的砂轮法兰盘支撑砂轮可以减小砂轮破裂的可能性。切割砂轮的法兰盘可以不同于砂轮的法兰盘。
- e) 不要使用从大规格电动工具上用剩的磨损砂轮。用于大规格电动工具上的砂轮不适于较小规格工具的高速工况并可能会爆裂。

剩余风险

尽管遵守了相关的安全法规并采用了安全装备，某些剩余风险仍然是无法避免的。这些风险包括：

- 听力损伤
- 飞散碎木料造成的人身伤害风险。
- 操作过程中附件加热而产生的烧伤危险。
- 长时间使用导致的人身伤害风险。
- 有害物质粉尘引起的风险。

工具上的标记

工具上印有下列标志：



使用前请阅读使用手册。



请佩戴听力保护器。



请佩戴护目装备。

日期码位置（图 1）

日期码 (n) 印在工具外壳上，其中还包含制造年份。

例如：

2015 XX JN

制造年份

包装内容

本产品包装内含有：

- 1 角磨机
- 1 护罩
- 1 法兰套件
- 1 带销扳手
- 1 手柄（仅适用于 STGS7100/STGS6100）
- 1 使用手册
 - 检查工具、部件或附件是否在运输过程中损坏。
 - 操作前，请抽空仔细阅读并掌握本手册。

描述（图 1）



警告：切勿改装电动工具或其任何部件，

否则可能会导致损坏或人身伤害。

- a. “开/关”开关
- b. 轴锁
- c. 护罩

设计用途

此角磨机设计用于专业磨削应用。

禁止使用中心凹陷砂轮片以外的砂轮片和砂纸盘。

请勿在潮湿环境中或在有易燃液体或气体的环境中使用。

本重型角磨机是专业型电动工具。

请勿让儿童接触本工具。缺乏经验的操作员需要在监督下使用本工具。

电气安全

电机只适用一种工作电压。请务必检查电源电压是否与铭牌上的电压一致。



您的史丹利工具带有双重绝缘，因此无需接地线。

电源线损坏时，必须由史丹利服务部门采用专门制备的电线进行更换。

使用延长电缆

如需使用延长电缆，请使用与本工具的输入功率（见技术数据）匹配的经检验 3 芯延长线。最小导体尺寸为 1.5 平方毫米，最大长度为 30 米。

使用电缆卷筒时，请务必拉出所有的电缆。

组装和调整



警告：为降低严重的人身伤害风险，在进行任何调整或取出 / 安装配件或附件之前，请关闭工具电源和断开工具电源连接。重新连接工具之前，请按下并松开触发开关以确保工具已关闭。

安装和取出护罩（图 2）



警告：为降低严重的人身伤害风险，在进行任何调整或取出 / 安装配件或附件之前，请关闭工具电源和断开工具电源连接。重新连接工具之前，请按下并松开触发开关以确保工具已关闭。

安装护罩

1. 将主机放置在工作台上，槽口朝上。
2. 将护罩 (c) 卡箍上的凸缘对准轴承座上的槽口 (i)。
3. 将护罩 (c) 按逆时针旋转 150 度。
4. 确认将螺钉 (k) 拧紧。

拆除护罩

1. 松开护罩卡箍上的螺钉 (k)。
2. 将护罩 (c) 往上拉。



警告：切勿在没有安装护罩的情况下使用本工具。

注：请参阅本节结束处的磨削附件图表，查看可与本角磨机配合使用的其他附件。

安装和拆除砂轮片（图 3、4）



警告：禁止使用破损砂轮片。

1. 将工具放置在工作台上，护罩朝上。
2. 将内法兰 (d) 正确安装到输出轴 (e) 上（图 3）。
3. 将砂轮片 (f) 放置在内法兰 (d) 上。安装中心凸起的砂轮片时，确保凸起的中心 (g) 面向内法兰 (d)。
4. 将外法兰 (h) 拧紧到输出轴 (e) 上（图 4）。安装砂轮片时，外法兰 (h) 上的圆环必须面向砂轮片。
5. 按下主轴锁 (b)，防止主轴 (e) 旋转，直到其锁定到位。
6. 使用双销扳手拧紧外法兰 (h)。

使用前的准备工作

- 安装护罩及合适的磨片或砂轮片。禁止使用过度磨损的磨片或砂轮片。
- 确保内部和外部法兰已正确安装。
- 确保磨片或砂轮片按附件和工具上的箭头方向转动。

操作（图 5）

使用说明



警告：请务必遵守安全指示和适用法规。



警告：为降低严重的人身伤害风险，在进行任何调整或取出 / 安装配件或附件之前，请关闭工具电源和断开工具电源连接。重新连接工具之前，请按下并松开触发开关以确保工具已关闭。

**警告：**

- 确保所有要磨削的材料已固定到位。
- 轻轻地对工具施加压力。切勿对磨片施加侧压力。
- 避免过载。如果工具变得灼热，请让它在空载情况下运转几分钟。

1. 请务必双手紧握工具（一只手握住外壳，另一只手握住侧手柄）。启动工具，然后将砂轮至于工件上。
2. 通常砂轮片的边缘应于工件表面角度保持在 15 度到 30 度之间。
3. 在使用新砂轮片时，请勿沿 B 方向操作砂轮，否则，砂轮片会切入工件内。当砂轮片边缘经过使用被磨圆后方可按 A、B 任意方向操作。

启动与关闭 (图 1)

**警告：**使用工具之前，请检查手柄是否牢固拧紧。检查开关是否工作正常

工具插入电源前，检查按下开关后部时，开关是否处于“关闭 (o)”位置。

滑动开关 (STGS6100/7100)

启动工具时，压下开关后部，并向前推进开关，然后压下开关前部锁住开关。压下开关的后部即关闭。

拨杆开关 (STGT6100/7100)

启动工具时，拨杆开关选到“1”（通）位置，停止时，将其选到“0”（断）位置。

**警告：**不要在有负载时打开或关闭工具。

开关



警告：紧握工具主体以在启动时和使用过程中保持对工具的控制，直到砂轮或附件停止转动。确保砂轮完全停止后才放下工具。

注：若要减少工具意外移动，请勿在负载情况下开启或关闭工具。允许角磨机运转达到全速后再接触

工作表面。从工作表面提起工具，然后再关闭工具。允许工具停止转动后再将其放下。

侧滑开关 (STGS7100/STGS6100)

**警告：**将工具连接到电源之前，按下侧

滑开关的后部，然后松开，确保开关处于关闭位置。在工具的电源出现中断后，如激活接地故障断路器、丢弃断路器、意外拔下插头或断电，如上面所述确保侧滑开关处于关闭位置。如果连接电源后侧滑开关锁定为开启状态，工具将会意外启动。

若要启动工具，请将侧滑开关 (a) 滑向工具的前方。若要停止工具，请松开侧滑开关。要使工具连续运行，请将开关滑向工具的前方并向内按开关的前部。若要在连续运行模式停止工具，请按下侧滑开关的后部，然后松开。

拨杆开关 (STGT6100/7100)



警告：将工具连接到电源之前，确保开关处于关闭 (0) 位置。在工具的电源出现中断后，如激活接地故障断路器、丢弃断路器、意外拔下插头或断电，如上面所述确保拨杆开关处于关闭位置。如果连接电源后拨杆开关锁定为开启状态，工具将会意外启动。

若要启动工具，请将拨杆开关 (j) 拨向“1”位置。若要停止工具，请将拨杆开关 (j) 拨向“0”位置。要使工具连续运行，请将开关拨向“1”位置。若要在连续运行模式停止工具，请拨杆开关拨向“0”位置。

正确的手持方式 (图 6)



警告：为降低严重的人身伤害风险，请始终使用正确的手持方式，如图所示。



警告：为降低严重的人身伤害风险，预

期有突然反应时务必紧握住工具。正确的手持方式要求一只手握住侧手柄（图 6），另一只手握住工具主体，如图 6 所示。

轴锁（图 1）

主轴锁 (b) 可在安装或拆除砂轮机片时防止输出轴转动。只能在工具关闭、拔出电源插头且完全停止时使用轴锁。



注意：为了降低工具损坏的风险，请勿在工具运行时使用轴锁。否则将损坏工具，附着的附件可能会甩脱，从而导致伤害。

若要使用轴锁，请按下轴锁按钮并转动输出轴，直到无法再转动为止。

金属应用

将工具用于金属时，确保已插入漏电保护器 (RCD) 以避免金属屑导致的剩余风险。

如果 RCD 切断电源，请将工具送交史丹利授权维修代理。



警告：在极端工作条件下，处理金属时，机壳内部可能会积聚导电粉尘。这可能导致机器中的保护绝缘变弱，可能有触电的风险。

若要避免在机器内部积聚金属屑，我们建议每天清洁通风槽。请参阅维护。

使用砂轮片



警告：金属粉尘积聚。在金属应用中过度使用砂轮片可能会增加触电的风险。若要降低此风险，使用前请插入 RCD，并每天清洁通风槽，按照以下维护说明将干燥的压缩空气吹入通风槽。

维护

史丹利电动工具设计精良，可以长期使用，而且只需最少的维护。要连续获得令人满意的工作效果，需要进行合适的工具维护和定期清洁。



警告：为降低严重的人身伤害风险，在进行任何调整或取出 / 安装配件或附件之前，请关闭工具电源和断开工具电源连接。重新连接工具之前，请按下并松开触发开关以确保工具已关闭。



润滑

本电动工具无需另行润滑。



清洁



警告：一旦通风口和周围积聚了可见的粉尘，请立即用干燥的空气吹走主机外壳内的粉尘和灰尘。执行此过程时，需戴上经认可的护目装备和防尘面具。



警告：切勿使用溶剂或其他刺激性化学制品来清洁工具的非金属部件。这些化学物质可能会削弱这些部件使用的材料。请用布蘸温和的肥皂水擦拭。切勿让任何液体渗入工具，切勿让工具的任何部分浸在液体中。

可选附件



警告：除了史丹利提供的附件之外，其他附件都未经此产品兼容性测试，若将此类附件与本工具一起使用将存在安全隐患。为降低人身伤害风险，本产品只可使用史丹利推荐的附件。

请向您的经销商咨询更多关于合适附件的信息。

保护环境



分类回收。本产品不得与普通家庭垃圾一起处理。

如果您发现您的史丹利产品需要更换或您已经不再需要使用这些产品，请不要将它们与家庭垃圾一起处理。请将它们单独分类回收。



分类回收使用过的产品和包装能够让材料得以再循环和再利用。再生材料的再利用有助于防止环境污染，并降低对原材料的需求。

当地法规可能要求由市政废物处理点或向您出售新产品的零售商提供从家庭中分类回收电气产品的服务。

史丹利提供设施收集和回收使用寿命到期的史丹利产品。若要享受这项服务，请将产品送回任一授权维修代理，他们将代表我们回收您的产品。

备注

- 史丹利的政策是持续改善我们的产品，因此，我们保留随时变更产品规格的权利，恕不另行通知。
- 标准设备和配件可能会根据不同的国家而有所不同。
- 产品规格可能会根据不同的国家而有所不同。
- 并非所有的国家都有提供完整的产品系列。如需各产品系列的供应情况，请联络您当地的史丹利代理商。

制造商：史丹利五金工具（上海）有限公司

制造商地址：上海市外高桥保税区泰谷路 88 号

丰谷大楼六层 676A 室

产地：江苏启东