

**DEWALT®**

**[www.DEWALT.com](http://www.DEWALT.com)**

**DWE7492**

---

English

7

---

简体中文

21

---

Fig. A  
图 A

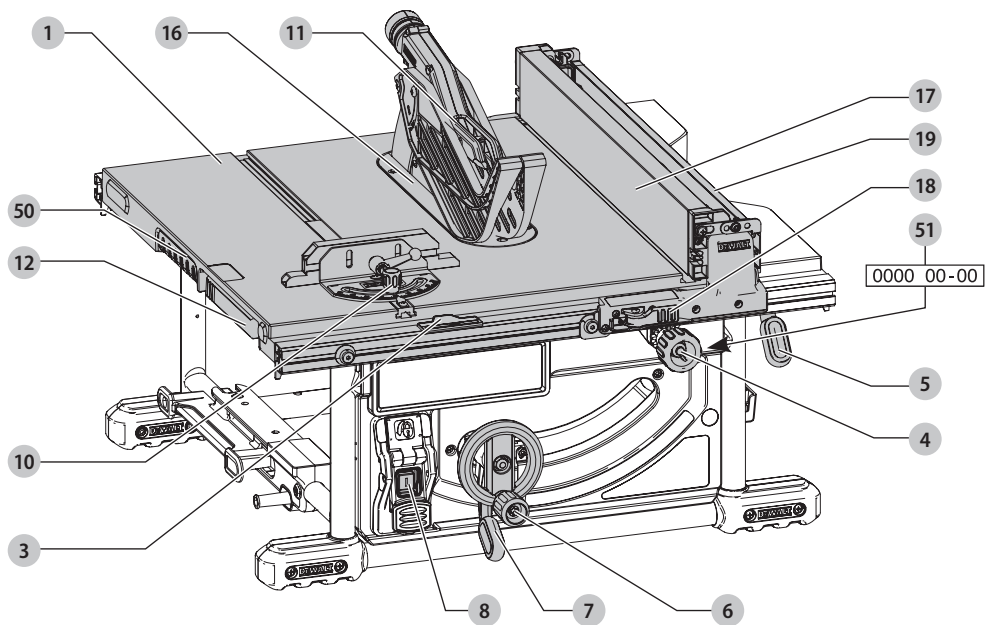

Fig. B  
图 B

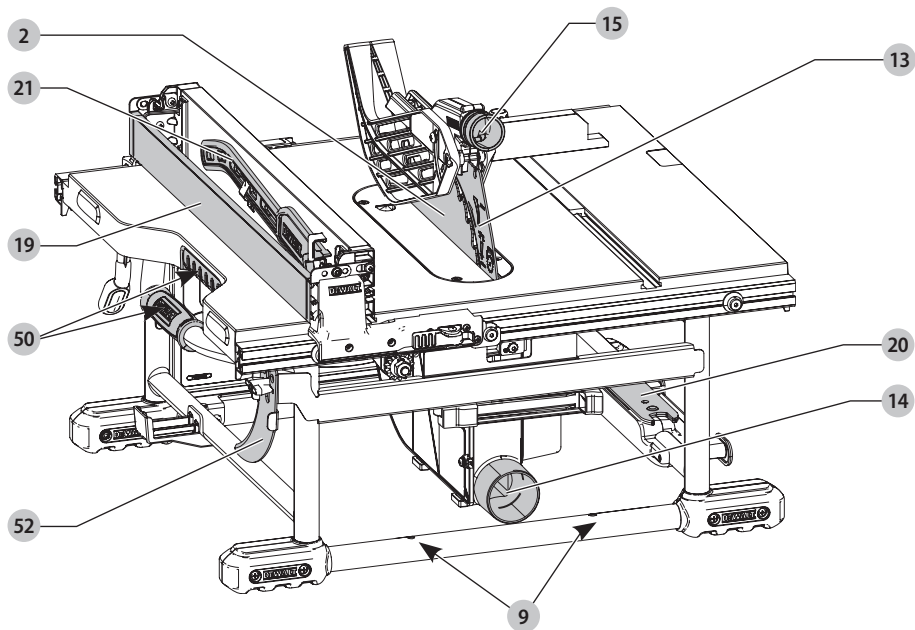

Fig. C  
图 C

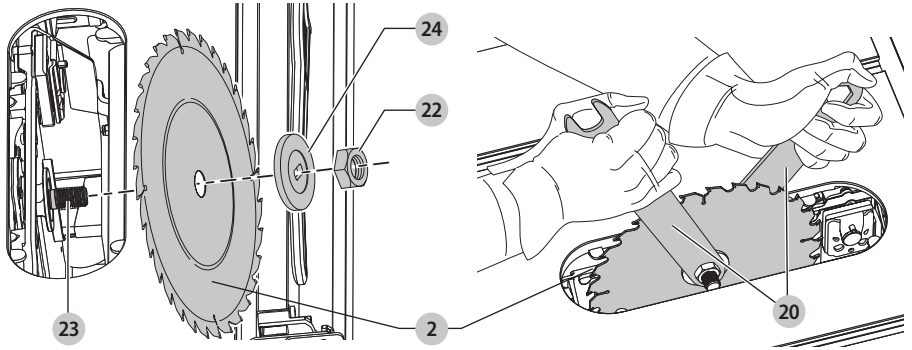

Fig. D  
图 D

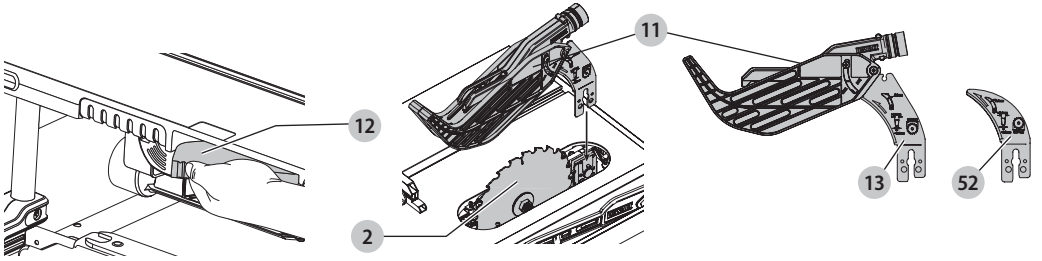

Fig. E  
图 E

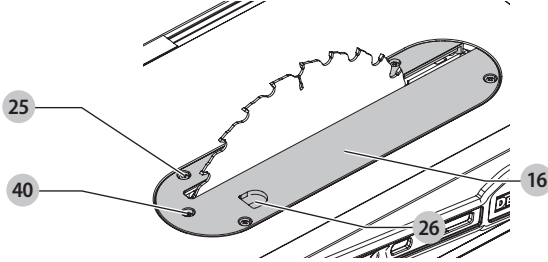

Fig. F  
图 F

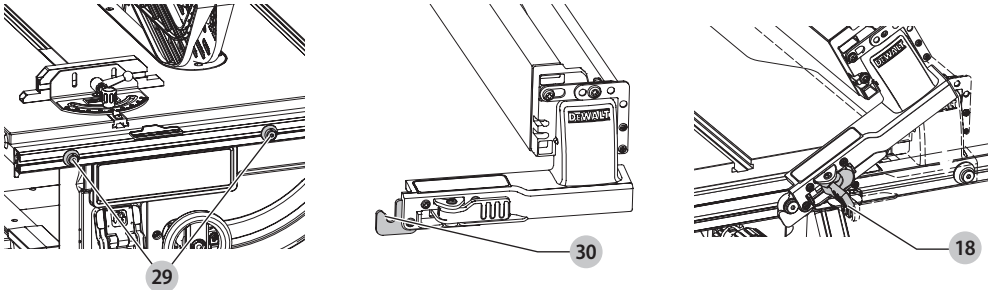

Fig. G  
图 G

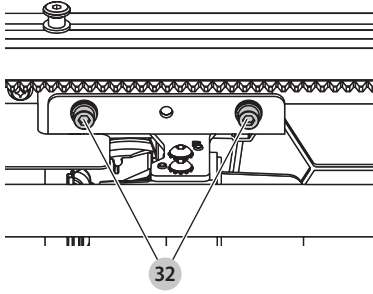

Fig. H  
图 H

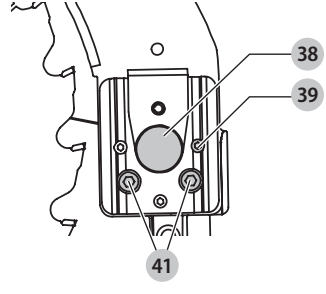

Fig. I  
图 I

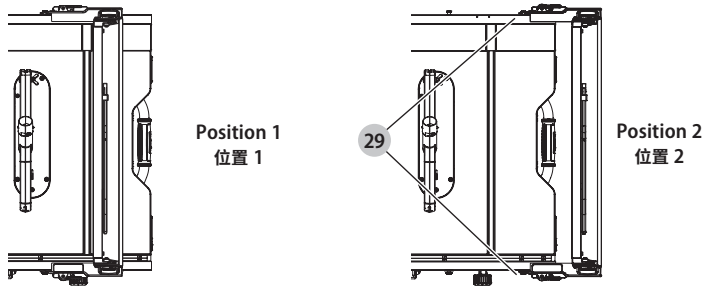

Fig. J  
图 J

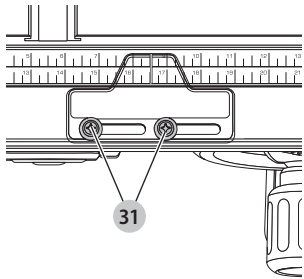

Fig. K  
图 K

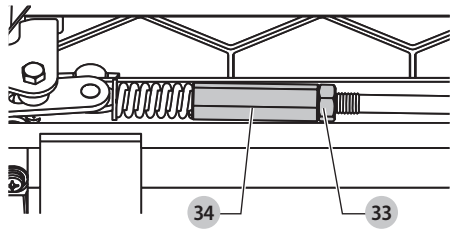

Fig. L  
图 L

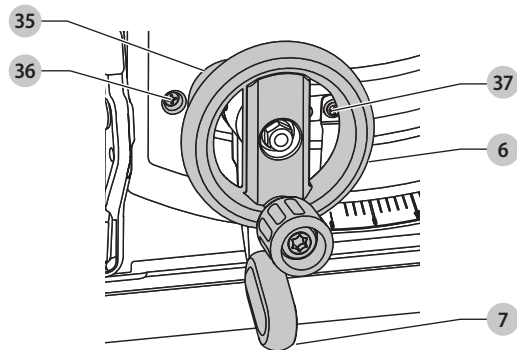

Fig. M  
图 M

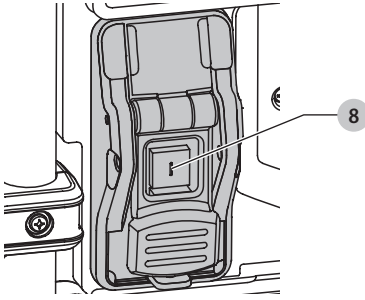

Fig. N  
图 N

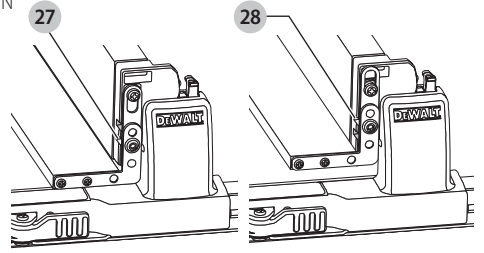

Fig. O  
图 O

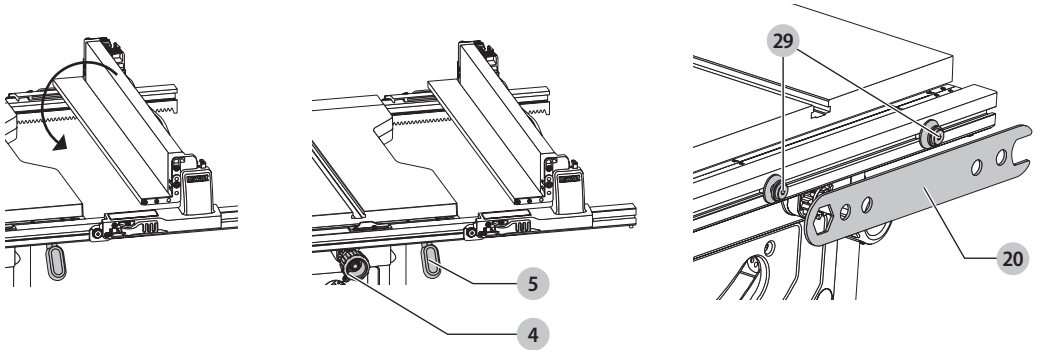

Fig. P  
图 P

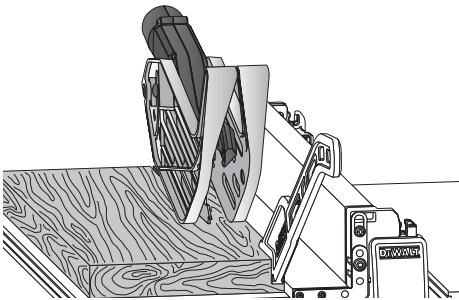

Fig. Q  
图 Q

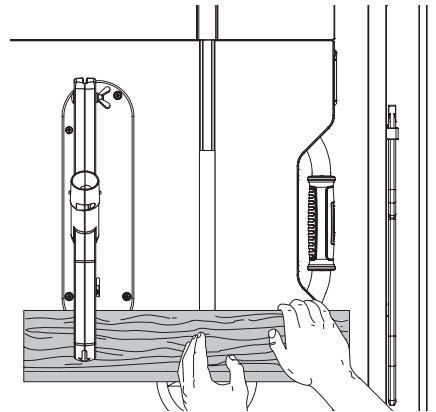

Fig. R  
图 R

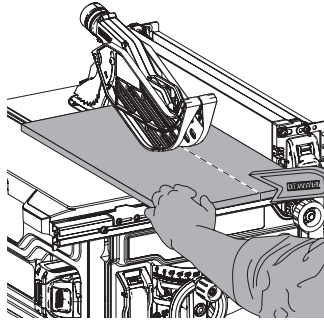

Fig. S  
图 S

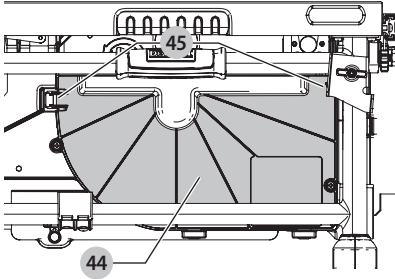

Fig. T  
图 T

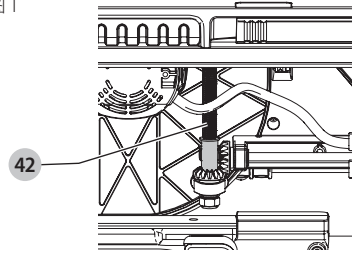

Fig. U  
图 U

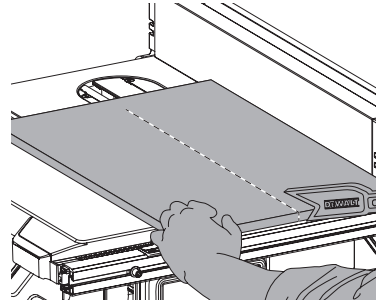
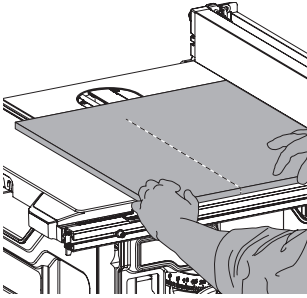

Fig. V  
图 V

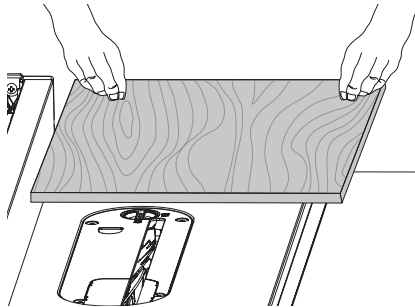

Fig. W  
图 W

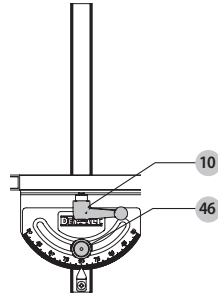
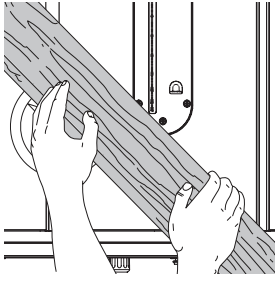

Fig. X  
图 X

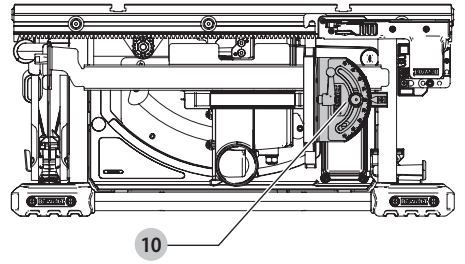
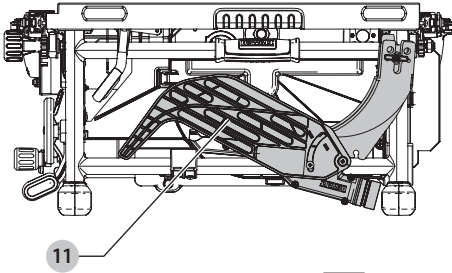

Fig. Y  
图 Y

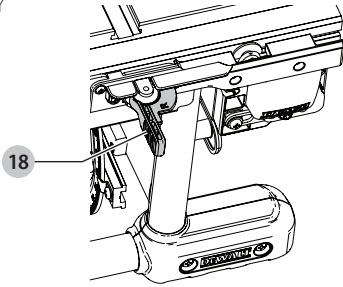

Fig. Z  
图 Z

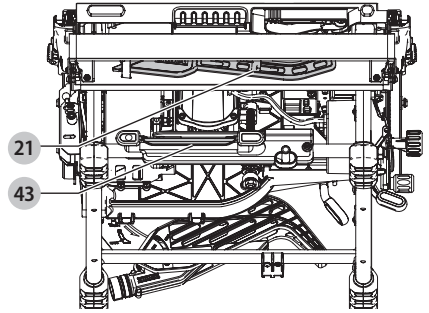
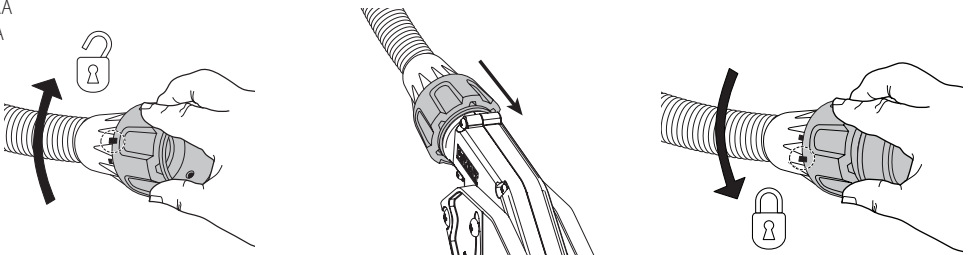

Fig. AA  
图 AA





# TABLE SAW

## DWE7492

### Congratulations!

You have chosen a DEWALT tool. Years of experience, thorough product development and innovation make DEWALT one of the most reliable partners for professional power tool users.

### Technical Data

		DWE7492-B1	DWE7492-IN/A9
Voltage	V <sub>AC</sub>	220-240	220-240
Motor power (input)	W	2000	2000
Motor power (output)	W	1200	1200
No load speed	min <sup>-1</sup>	4800	4800
Blade diameter	mm	250	254
Blade bore	mm	25.4	25.4
Blade body thickness	mm	<2.2	2.0
Riving knife thickness	mm	2.3	2.2
Depth of cut at 90°	mm	77	79
Depth of cut at 45°	mm	55	57
Bevel angle	°	45-90	45-90
Maximum bevel angle	°	45-90	45-90
Mitre angle	°	30-90	30-90
Ripping capacity	mm	825	825
Overall dimensions	mm	680 x 650 x 330	680 x 650 x 330
Weight	kg	26.5	26.5

### Definitions: Safety Guidelines

The definitions below describe the level of severity for each signal word. Please read the manual and pay attention to these symbols.



**DANGER:** Indicates an imminently hazardous situation which, if not avoided, **will** result in **death or serious injury**.



**WARNING:** Indicates a potentially hazardous situation which, if not avoided, **could** result in **death or serious injury**.



**CAUTION:** Indicates a potentially hazardous situation which, if not avoided, **may** result in **minor or moderate injury**.

**NOTICE:** Indicates a practice **not related to personal injury** which, if not avoided, **may** result in **property damage**.



Denotes risk of electric shock.



Denotes risk of fire.

### General Power Tool Safety Warnings



**WARNING:** Read all safety warnings, instructions, illustrations and specifications provided with this power tool. Failure to follow all instructions listed below may result in electric shock, fire and/or serious injury.

#### SAVE ALL WARNINGS AND INSTRUCTIONS FOR FUTURE REFERENCE

The term "power tool" in the warnings refers to your mains-operated (corded) power tool or battery-operated (cordless) power tool.

#### 1) Work area safety

- Keep work area clean and well lit.** Cluttered or dark areas invite accidents.
- Do not operate power tools in explosive atmospheres, such as in the presence of flammable liquids, gases or dust.** Power tools create sparks which may ignite the dust or fumes.
- Keep children and bystanders away while operating a power tool.** Distractions can cause you to lose control.

#### 2) Electrical safety

- Power tool plugs must match the outlet. Never modify the plug in any way. Do not use any adapter plugs with earthed (grounded) power tools.** Unmodified plugs and matching outlets will reduce risk of electric shock.
- Avoid body contact with earthed or grounded surfaces such as pipes, radiators, ranges and refrigerators.** There is an increased risk of electric shock if your body is earthed or grounded.
- Do not expose power tools to rain or wet conditions.** Water entering a power tool will increase the risk of electric shock.
- Do not abuse the cord. Never use the cord for carrying, pulling or unplugging the power tool. Keep cord away from heat, oil, sharp edges or moving parts.** Damaged or entangled cords increase the risk of electric shock.
- When operating a power tool outdoors, use an extension cord suitable for outdoor use.** Use of a cord suitable for outdoor use reduces the risk of electric shock.
- If operating a power tool in a damp location is unavoidable, use a residual current device (RCD) protected supply.** Use of an RCD reduces the risk of electric shock.

#### 3) Personal safety

- Stay alert, watch what you are doing and use common sense when operating a power tool. Do not use a power tool while you are tired or under the influence of drugs, alcohol or medication.** A moment

of inattention while operating power tools may result in serious personal injury.

- b) **Use personal protective equipment. Always wear eye protection.** Protective equipment such as dust mask, non-skid safety shoes, hard hat, or hearing protection used for appropriate conditions will reduce personal injuries.
- c) **Prevent unintentional starting. Ensure the switch is in the off position before connecting to power source and/or battery pack, picking up or carrying the tool.** Carrying power tools with your finger on the switch or energising power tools that have the switch on invites accidents.
- d) **Remove any adjusting key or wrench before turning the power tool on.** A wrench or a key left attached to a rotating part of the power tool may result in personal injury.
- e) **Do not overreach. Keep proper footing and balance at all times.** This enables better control of the power tool in unexpected situations.
- f) **Dress properly. Do not wear loose clothing or jewellery. Keep your hair, clothing and gloves away from moving parts.** Loose clothes, jewellery or long hair can be caught in moving parts.
- g) **If devices are provided for the connection of dust extraction and collection facilities, ensure these are connected and properly used.** Use of dust collection can reduce dust-related hazards.
- h) **Do not let familiarity gained from frequent use of tools allow you to become complacent and ignore tool safety principles.** A careless action can cause severe injury within a fraction of a second.

#### 4) Power tool use and care

- a) **Do not force the power tool. Use the correct power tool for your application.** The correct power tool will do the job better and safer at the rate for which it was designed.
- b) **Do not use the power tool if the switch does not turn it on and off.** Any power tool that cannot be controlled with the switch is dangerous and must be repaired.
- c) **Disconnect the plug from the power source and/or remove the battery pack, if detachable, from the power tool before making any adjustments, changing accessories, or storing power tools.** Such preventive safety measures reduce the risk of starting the power tool accidentally.
- d) **Store idle power tools out of the reach of children and do not allow persons unfamiliar with the power tool or these instructions to operate the power tool.** Power tools are dangerous in the hands of untrained users.
- e) **Maintain power tools and accessories. Check for misalignment or binding of moving parts, breakage of parts and any other condition that may affect the power tool's operation. If damaged, have the power tool repaired before use.** Many accidents are caused by poorly maintained power tools.
- f) **Keep cutting tools sharp and clean.** Properly maintained cutting tools with sharp cutting edges are less likely to bind and are easier to control.
- g) **Use the power tool, accessories and tool bits etc., in accordance with these instructions taking into account the working conditions and the work to be performed.** Use of the power tool for operations different from those intended could result in a hazardous situation.
- h) **Keep handles and grasping surfaces dry, clean and free from oil and grease.** Slippery handles and grasping surfaces do not allow for safe handling and control of the tool in unexpected situations.

#### 5) Service

- a) **Have your power tool serviced by a qualified repair person using only identical replacement parts.** This will ensure that the safety of the power tool is maintained.

### Safety Instructions for Table Saws

#### 1) Guarding Related Warnings

- a) **Keep guards in place. Guards must be in working order and be properly mounted.** A guard that is loose, damaged, or is not functioning correctly must be repaired or replaced.
- b) **Always use saw blade guard, riving knife and anti-kickback pawls for every through-cutting operation.** For through-cutting operations where the saw blade cuts completely through the thickness of the workpiece, the guard and other safety devices help reduce the risk of injury.
- c) **Immediately reattach the guarding system after completing an operation (such as rabbeting cuts) which requires removal of the guard, riving knife and/or anti-kickback device.** The guard, riving knife, and anti-kickback device help to reduce the risk of injury.
- d) **Make sure the saw blade is not contacting the guard, riving knife or the workpiece before the switch is turned on.** Inadvertent contact of these items with the saw blade could cause a hazardous condition.
- e) **Adjust the riving knife as described in this instruction manual.** Incorrect spacing, positioning and alignment can make the riving knife ineffective in reducing the likelihood of kickback.
- f) **For the riving knife and anti-kickback pawls to work, they must be engaged in the workpiece.** The riving knife and anti-kickback pawls are ineffective when cutting workpieces that are too short to be engaged with the riving knife and anti-kickback pawls. Under these conditions a kickback cannot be prevented by the riving knife and anti-kickback pawls.
- g) **Use the appropriate saw blade for the riving knife.** For the riving knife to function properly, the saw blade diameter must match the appropriate riving knife and the body of the saw blade must be thinner than the thickness of the riving knife and the cutting width of the saw blade must be wider than the thickness of the riving knife.

## 2) Cutting Procedures Warnings

- a)  **DANGER: Never place your fingers or hands in the vicinity or in line with the saw blade.** A moment of inattention or a slip could direct your hand towards the saw blade and result in serious personal injury.
- b) **Feed the workpiece into the saw blade or cutter only against the direction of rotation.** Feeding the workpiece in the same direction that the saw blade is rotating above the table may result in the workpiece, and your hand, being pulled into the saw blade.
- c) **Never use the mitre gauge to feed the workpiece when ripping and do not use the rip fence as a length stop when cross cutting with the mitre gauge.** Guiding the workpiece with the rip fence and the mitre gauge at the same time increases the likelihood of saw blade binding and kickback.
- d) **When ripping, always apply the workpiece feeding force between the fence and the saw blade. Use a push stick when the distance between the fence and the saw blade is less than 150 mm, and use a push block when this distance is less than 50 mm.** "Work helping" devices will keep your hand at a safe distance from the saw blade.
- e) **Use only the push stick provided by the manufacturer or constructed in accordance with the instructions.** This push stick provides sufficient distance of the hand from the saw blade.
- f) **Never use a damaged or cut push stick.** A damaged push stick may break causing your hand to slip into the saw blade.
- g) **Do not perform any operation "freehand". Always use either the rip fence or the mitre gauge to position and guide the workpiece.** "Freehand" means using your hands to support or guide the workpiece, in lieu of a rip fence or mitre gauge. Freehand sawing leads to misalignment, binding and kickback.
- h) **Never reach around or over a rotating saw blade.** Reaching for a workpiece may lead to accidental contact with the moving saw blade.
- i) **Provide auxiliary workpiece support to the rear and/or sides of the saw table for long and/or wide workpieces to keep them level.** A long and/or wide workpiece has a tendency to pivot on the table's edge, causing loss of control, saw blade binding and kickback.
- j) **Feed workpiece at an even pace. Do not bend or twist the workpiece. If jamming occurs, turn the tool off immediately, unplug the tool then clear the jam.** Jamming the saw blade by the workpiece can cause kickback or stall the motor.
- k) **Do not remove pieces of cut-off material while the saw is running.** The material may become trapped between the fence or inside the saw blade guard and the saw blade pulling your fingers into the saw blade. Turn the saw off and wait until the saw blade stops before removing material.

- l) **Use an auxiliary fence in contact with the table top when ripping workpieces less than 2 mm thick.** A thin workpiece may wedge under the rip fence and create a kickback.

## 3) Kickback Causes and Related Warnings

Kickback is a sudden reaction of the workpiece due to a pinched, jammed saw blade or misaligned line of cut in the workpiece with respect to the saw blade or when a part of the workpiece binds between the saw blade and the rip fence or other fixed object. Most frequently during kickback, the workpiece is lifted from the table by the rear portion of the saw blade and is propelled towards the operator.

Kickback is the result of saw misuse and/or incorrect operating procedures or conditions and can be avoided by taking proper precautions as given below.

- a) **Never stand directly in line with the saw blade. Always position your body on the same side of the saw blade as the fence.** Kickback may propel the workpiece at high velocity towards anyone standing in front and in line with the saw blade.
- b) **Never reach over or in back of the saw blade to pull or to support the workpiece.** Accidental contact with the saw blade may occur or kickback may drag your fingers into the saw blade.
- c) **Never hold and press the workpiece that is being cut off against the rotating saw blade.** Pressing the workpiece being cut off against the saw blade will create a binding condition and kickback.
- d) **Align the fence to be parallel with the saw blade.** A misaligned fence will pinch the workpiece against the saw blade and create kickback.
- e) **Use a featherboard to guide the workpiece against the table and fence when making non-through cuts such as rabbeting cuts.** A featherboard helps to control the workpiece in the event of a kickback.
- f) **Support large panels to minimise the risk of saw blade pinching and kickback.** Large panels tend to sag under their own weight. Support(s) must be placed under all portions of the panel overhanging the table top.
- g) **Use extra caution when cutting a workpiece that is twisted, knotted, warped or does not have a straight edge to guide it with a mitre gauge or along the fence.** A warped, knotted, or twisted workpiece is unstable and causes misalignment of the kerf with the saw blade, binding and kickback.
- h) **Never cut more than one workpiece, stacked vertically or horizontally.** The saw blade could pick up one or more pieces and cause kickback.
- i) **When restarting the saw with the saw blade in the workpiece, centre the saw blade in the kerf so that the saw teeth are not engaged in the material.** If the saw blade binds, it may lift up the workpiece and cause kickback when the saw is restarted.
- j) **Keep saw blades clean, sharp, and with sufficient set. Never use warped saw blades or saw blades with**

**cracked or broken teeth.** Sharp and properly set saw blades minimise binding, stalling and kickback.

#### 4) Table Saw Operating Procedure Warnings

- a) **Turn off the table saw and disconnect from the power source when removing the table insert, changing the saw blade or making adjustments to the riving knife, anti-kickback pawls or saw blade guard, and when the machine is left unattended.** Precautionary measures will avoid accidents.
  - b) **Never leave the table saw running unattended. Turn it off and don't leave the tool until it comes to a complete stop.** An unattended running saw is an uncontrolled hazard.
  - c) **Locate the table saw in a well-lit and level area where you can maintain good footing and balance. It should be installed in an area that provides enough room to easily handle the size of your workpiece.** Cramped, dark areas, and uneven slippery floors invite accidents.
  - d) **Frequently clean and remove sawdust from under the saw table and/or the dust collection device.** Accumulated sawdust is combustible and may self-ignite.
  - e) **The table saw must be secured.** A table saw that is not properly secured may move or tip over.
  - f) **Remove tools, wood scraps, etc. from the table before the table saw is turned on.** Distraction or a potential jam can be dangerous.
  - g) **Always use saw blades with correct size and shape (diamond versus round) of arbour holes.** Saw blades that do not match the mounting hardware of the saw will run off-centre, causing loss of control.
  - h) **Never use damaged or incorrect saw blade mounting means such as flanges, saw blade washers, bolts or nuts.** These mounting means were specially designed for your saw, for safe operation and optimum performance.
  - i) **Never stand on the table saw, do not use it as a stepping stool.** Serious injury could occur if the tool is tipped or if the cutting tool is accidentally contacted.
  - j) **Make sure that the saw blade is installed to rotate in the proper direction. Do not use grinding wheels, wire brushes, or abrasive wheels on a table saw.** Improper saw blade installation or use of accessories not recommended may cause serious injury.
- **Keep arms, hands and fingers away from the blade to prevent serious injury.**
  - **Use a push stick that is appropriate to the application to push workpieces through the saw.** A push stick is a wooden or plastic stick, often homemade, that should be used whenever the size or shape of the workpiece would cause you to place your hands within 152 mm of the blade.
  - **Use hold-downs, jigs, fixtures or feather boards to help guide and control the workpiece.** Accessories for use with your tool are available at extra cost from your local dealer or authorized service centre.
  - **Do not perform ripping, crosscutting or any other operation freehand.**
  - **Never reach around or over saw blade while the blade is spinning.**
  - **Stability.** Make sure the table saw is firmly mounted to a secure surface before use and does not move.
  - **The table saw should only be set up on a level and stable surface.** The work area should be free from obstructions and trip hazards. No materials or tools should be leaned against the saw.
  - **Never cut metals, cement board or masonry.** Certain man-made materials have special instructions for cutting on table saws. Follow the manufacturer's recommendations at all times. Damage to the saw and personal injury may result.
  - Do not install a diamond masonry blade and attempt to use the table saw as a wet saw.
  - **The proper throat plate must be locked in place at all times to reduce the risk of a thrown workpiece and possible injury.**
  - **Wear gloves when handling saw blades.**
  - **Use the correct saw blade for the intended operation.** The blade must rotate toward the front of the saw. Always tighten the blade arbor nut securely. Before use, inspect the blade for cracks or missing teeth. Do not use a damaged or dull blade.
  - **Never attempt to free a stalled saw blade without first turning the machine off and disconnect tool from power source.** If a workpiece or cut-off piece becomes trapped inside the blade guard assembly, turn saw off and wait for blade to stop before lifting the blade guard assembly and removing the piece.
  - **Never start the machine with the workpiece against the blade to reduce the risk of a thrown workpiece and personal injury.**
  - **Do not have any part of your body in line with the blade.** Personal injury may occur. Stand to either side of the blade.
  - **Never perform layout, assembly or set-up work on the table/work area when the machine is running.** A sudden slip could cause a hand to move into the blade. Severe injury can result.

#### Additional Safety Rules for Table Saws



**WARNING:** Cutting plastics, sap coated wood, and other materials may cause melted material to accumulate on the blade tips and the body of the saw blade, increasing the risk of blade overheating and binding while cutting.

- **Avoid awkward positions, where a sudden slip could cause a hand to move into a saw blade.**
- **Do not attempt to retrieve materials near the blade on the saw table while the blade is spinning.**
- **Never reach in back of, or around, the cutting tool with either hand to hold down the workpiece.**

- **Never perform any adjustments while the saw is running such as fence repositioning or removal, bevel lock adjustment, or blade height adjustment.**
- **Clean the table/work area before leaving the machine.**  
Lock the switch in the "OFF" position and disconnect tool from power source to prevent unauthorized use.
- **Always lock the fence and bevel adjustment before cutting.**
- **Avoid overheating the saw blade tips.** Keep material moving and parallel with the fence. Do not force work into the blade.
- **If cutting plastic materials, avoid melting the plastic.**
- **Do not leave a long board (or other workpiece) unsupported so the spring of the board causes it to shift on the table resulting in loss of control and possible injury.** Provide proper support for the workpiece, based on its size and the type of operation to be performed. Hold the work firmly against the fence and down against the table surface.
- **If this saw makes an unfamiliar noise or if it vibrates excessively, cease operating immediately, turn unit off and disconnect tool from power source until the problem has been located and corrected.** Contact a DEWALT factory service centre, a DEWALT authorized service centre or other qualified service personnel if the problem can not be found.
- **Do not operate this machine until it is completely assembled and installed according to the instructions.** A machine incorrectly assembled can cause serious injury.
- **Never attempt to cut a stack of loose pieces of material which could cause loss of control or kickback.** Support all materials securely.

## Saw Blades



**WARNING:** to minimise the risk of kickback and to ensure proper cutting, the splitter and riving knife must be the proper thickness for the blade used. If a different blade is used, check the blade body (plate) thickness and the blade kerf (cutting) width marked on the blade or on the blade packaging. The splitter and riving knife thickness must be greater than the body thickness and less than the kerf width.

- Do not use saw blades that do not conform to the dimensions stated in the **Technical Data**. Do not use any spacers to make a blade fit onto the spindle. Use only the blades specified in this manual, complying with EN847-1, if intended for wood and similar materials.
- Consider applying specially designed noise-reduction blades.
- Do not use high steel (HS) saw blades.
- Do not use cracked or damaged saw blades.
- Ensure that the chosen saw blade is suitable for the material to be cut.
- Always wear gloves for handling saw blades and rough material. Saw blades should be carried in a holder wherever practicable.

## Residual risks

The following risks are inherent to the use of saws:

- *injuries caused by touching the rotating parts*
- In spite of the application of the relevant safety regulations and the implementation of safety devices, certain residual risks cannot be avoided. These are:
- *Impairment of hearing.*
  - *Risk of accidents caused by the uncovered parts of the rotating saw blade.*
  - *Risk of injury when changing the saw blade with unprotected hands.*
  - *Risk of squeezing fingers when opening the guards.*
  - *Health hazards caused by breathing dust developed when sawing wood, especially oak, beech and MDF.*

The following factors are of influence to noise production:

- *the material to be cut*
- *the type of saw blade*
- *the feed force*
- *machine maintenance*

The following factors are of influence to dust exposure:

- *worn saw blade*
- *dust extractor with air velocity less than 20 m/s*
- *workpiece not exactly guided*

## Electrical Safety

The electric motor has been designed for one voltage only. Always check that the power supply corresponds to the voltage on the rating plate.



Your DEWALT tool is double insulated in accordance with IEC62841; therefore no earth wire is required.



**WARNING:** 220-240V units have to be operated via a fail-safe isolating transformer with an earth screen between the primary and secondary winding.

If the supply cord is damaged, it must be replaced only by DEWALT or an authorised service organisation.

**NOTE:** This device is intended for the connection to a power supply system with maximum permissible system impedance  $Z_{max}$  of 0.28  $\Omega$  at the interface point (power service box) of user's supply. The user has to ensure that this device is connected only to a power system which fulfills the requirement above. If necessary, the user can ask the public power supply company for the system impedance at the interface point.

## Using an Extension Cable

If an extension cable is required, use an approved 3-core extension cable suitable for the power input of this tool (see **Technical Data**). The minimum conductor size is 1.5 mm<sup>2</sup>; the maximum length is 30 m.

When using a cable reel, always unwind the cable completely.

## Package Contents

The package contains:

- 1 Partly assembled machine
- 1 Rip fence
- 1 Mitre gauge
- 1 Upper blade guard assembly
- 1 Throat plate
- 2 Blade wrenches
- 1 Push Stick
- 1 Dust extraction adapter
- 1 Instruction manual
- Check for damage to the tool, parts or accessories which may have occurred during transport.
- Take the time to thoroughly read and understand this manual prior to operation.

## Markings on Tool

The following pictograms are shown on the tool:



Read instruction manual before use.



Wear ear protection.



Wear eye protection.



Wear respiratory protection.



Keep hands away from cutting area and the blade.



Riving knife or splitter thickness



Saw blade body thickness and kerf width



Saw blade diameter



Blade guard release lever



Lock/unlock cover at the main switch.



Unplug saw before changing blade



Protect the supply cord/plug against humidity and sharp edges of saw blade

## Date Code Position (Fig. A)

The Date Code **51**, which also includes the year of manufacture, is printed into the housing.

Example:

2021 XX XX

Year of Manufacture

## Description (Fig. A, B)



**WARNING:** Never modify the power tool or any part of it. Damage or personal injury could result.

- 1 Table
- 2 Blade(Blade sold separately)
- 3 Rip scale indicator
- 4 Fine adjust knob
- 5 Rail lock lever
- 6 Blade height adjustment wheel
- 7 Bevel lock lever
- 8 ON/OFF switch
- 9 Mounting holes
- 10 Mitre gauge
- 11 Blade guard assembly
- 12 Blade guard release lever
- 13 Splitter
- 14 Dust exhaust port
- 15 Guard dust exhaust port
- 16 Throat plate
- 17 Rip fence
- 18 Rip fence latch
- 19 Work support/narrow rip fence (shown in stored position)
- 20 Blade wrenches
- 21 Push stick (shown in stored position)
- 50 Carrying handles
- 52 Non-through cutting riving knife (shown in storage position)

## Intended Use

DWE7492 table saw is designed for professional ripping, cross-cutting, mitreing and bevelling with various materials as wood, wood composite materials and plastics.

**DO NOT** use under wet conditions or in the presence of flammable liquids or gases.

**DO NOT** use for cutting metal, cement board, or masonry.

**DO NOT** use shaping cutter heads on this saw.

**DO NOT** perform tapered cuts without a tapered jig accessory.

**DO NOT** use the saw for plunge or cove cutting.

These table saws are professional power tools.

**DO NOT** let children come into contact with the tool.

Supervision is required when inexperienced operators use this tool.

- **Young children and the infirm.** This appliance is not intended for use by young children or infirm persons without supervision. This product is not intended for use by persons (including children) suffering from diminished physical, sensory or mental abilities; lack of experience, knowledge or skills unless they are supervised by a person responsible for their safety. Children should never be left alone with this product.

## ASSEMBLY

- ⚠ **WARNING:** To reduce the risk of serious personal injury, turn tool off and disconnect tool from power source before making any adjustments or removing/installing attachments or accessories. An accidental start-up can cause injury.

## Unpacking

- Remove the saw from the packaging material carefully.
- The machine is fully assembled except for the rip fence, blade guard assembly, mitre gauge, blade wrenches, and dust extraction reducer port.
- Finalize the assembly following the instructions as described below.

- ⚠ **WARNING:** Always keep the push stick in its place when not in use.

## Mounting the Saw Blade (Fig. A, C)

- ⚠ **WARNING:** To reduce the risk of injury, turn unit off and disconnect machine from power source before installing and removing accessories, before adjusting or changing set-ups or when making repairs. An accidental start-up can cause injury.
- ⚠ **WARNING:** When mounting the saw blade, wear protective gloves. The teeth of the saw blades are very sharp and can be dangerous.
- ⚠ **WARNING:** The saw blade **MUST** be replaced as described in this section. **ONLY** use saw blades as specified under **Technical Data**.
- ⚠ **WARNING:** Do not touch the saw blade after working before it has cooled. The saw blade becomes very hot while working.

1. Raise the saw blade arbor to its maximum height by turning the blade height adjustment wheel **6** clockwise.
2. Remove the throat plate **16**. Refer to **Mounting the Throat Plate**.
3. Using wrenches **20**, loosen and remove the arbor nut **22** and flange **24** from the saw arbor by turning anti-clockwise.
4. Place the saw blade on to the spindle **23** making sure the teeth of the blade **2** point down at the front of the table. Assemble the washers and arbor nut to the spindle and tighten arbor nut **22** as far as possible by hand, making sure that the saw blade is against the inner washer and the outer flange **24** is against the blade. Ensure the largest diameter of the flange is against the blade. Ensure the spindle and washers are free from dust and debris.

5. To keep the spindle from rotating when tightening the arbor nut, use the open end of the blade wrench **20** to secure the spindle.
6. Using the arbor wrench, tighten the arbor nut **22** by turning it clockwise.
7. Replace the throat plate.

- ⚠ **WARNING:** Always check the rip fence pointer and the blade guard assembly after having changed the blade.

## Mounting the Blade Guard Assembly/Riving Knife (Fig. A, D)

- ⚠ **WARNING:** Use the guard assembly for all through cutting.
- ⚠ **WARNING:** Use the riving knife for non-through-cutting when blade guard assembly cannot be used.
- ⚠ **WARNING:** Do not insert both the blade guard assembly and the non-through-cutting riving knife into the clamp at the same time.

**NOTE:** The saw is shipped with the non-through-cutting riving knife installed.

1. Raise the saw blade arbor to its maximum height.
2. Install blade guard assembly by pulling the guard release lever **12** and inserting either the non-through-cutting riving knife **52** or the blade guard assembly **11** until it bottoms out.
3. Release lever, make sure clamp plates are fully closed and clamp the splitter securely.

- ⚠ **WARNING:** Before connecting the table saw to the power source or operating the saw, always inspect the blade guard assembly for proper alignment and clearance with saw blade. Check alignment after each change of bevel angle.
- ⚠ **WARNING:** To reduce the risk of serious personal injury, DO NOT operate saw if blade assembly is not securely clamped in place.

When properly aligned, the splitter **13** or riving knife **52** will be in line with the blade at both table top level, and at the top of the blade. Using a straight edge, ensure that the blade **2** is aligned with the splitter **13** or riving knife **52**. With power disconnected, operate the blade tilt and height adjustments through the extremes of travel and insure the blade guard assembly clears the blade in all operations. Refer to **Aligning Guard Assembly/Splitter to Blade**.

- ⚠ **WARNING:** Correct mounting and alignment of the blade guard assembly is essential to safe operation!

## To Remove the Blade Guard Assembly/Riving Knife (Fig. D)

1. Pull the guard release lever **12**.
2. Lift up on blade guard assembly **11** or riving knife **52**.

## Mounting the Throat Plate (Fig. E)

1. Align the throat plate **16** as shown in Figure E, and insert the tabs on the back of the throat plate into the holes on the back of the table opening.

- Turn the locking screw **40** clockwise 90° to lock the table insert in place.
- The throat plate includes four adjustment screws **25** which raise or lower the throat plate. When properly adjusted, the front of the throat plate should be flush or slightly below the surface of the table top and secured in place. The rear of the throat plate should be flush or slightly above the table top.



**WARNING:** Never use the machine without the throat plate. Immediately replace the throat plate when worn or damaged.

### To Remove the Throat Plate

- Remove the throat plate **16** by turning the locking screw **40** 90° anti-clockwise
- Using finger hole **26**, pull throat plate up and forward to expose the inside of the saw. DO NOT operate the saw without the throat plate. If using a dado blade, use proper dado throat plate (sold separately).

### Fitting the Rip Fence (Fig. F)

The rip fence can be installed in two positions on the right (Position 1 for 0 mm to 62 cm ripping, and Position 2 for 20.3 cm to 82.5 cm ripping) and one position on the left of your table saw.

- Unlock the rip fence latches **18**.
- Holding the fence at an angle, align the locator pins (front and back) **29** on the fence rails with the fence head slots **30**.
- Slide the head slots onto the pins and rotate the fence down until it rests on the rails.
- Lock the fence in place by closing the front and back latches **18** onto the rails.

### Bench Mounting (Fig. A)



**CAUTION:** To reduce the risk of personal injury, make sure table saw is firmly mounted to a stable surface before use.



**CAUTION:** Ensure that the surface is stable enough that large pieces of material will not cause it to tip over during use.

The table saw must be mounted firmly. Four holes **9** are provided in the tool's base for mounting. We strongly recommend that these holes be used to anchor the table saw to your workbench or other stationary rigid frame.

- Centre the saw on a square piece of 12.7 mm plywood.
- Mark the positions of the two rear mounting holes (spaced 220 mm apart) in the frame of the saw with a pencil. Then measure forward 498.5 mm for the two front holes spaced 230 mm apart.
- Remove the saw and drill 9 mm holes in the places you have just marked.
- Position the saw over the four holes you drilled in the plywood and insert four 8 mm machine screws FROM THE BOTTOM. Install washers and 8 mm nuts on the top. Tighten securely.
- In order to prevent the screw heads from marring the surface to which you clamp the saw, attach two strips of

scrap wood to the bottom of the plywood base. These strips can be attached with wood screws installed from the top side as long as they don't protrude through the bottom of the strip.

- Use a "C" clamp to secure the plywood base to your workbench whenever you use the saw.

## ADJUSTMENTS

### Blade Adjustment (Fig. G)

#### Blade Alignment (Parallel to Mitre Slot)



**WARNING:** Cut Hazard. Check the blade at 0° and 45° to make sure blade does not hit the throat plate, causing personal injury.

If the blade appears to be out of alignment with the mitre slot on the table top, it will require calibration for alignment. To realign the blade and mitre slot, use the following procedure:



**WARNING:** To reduce the risk of injury, turn unit off and disconnect machine from power source before installing and removing accessories, before adjusting or changing set-ups or when making repairs. An accidental start-up can cause injury.

- Using a 5 mm hex wrench, loosen rear pivot bracket fasteners **32**, located on the underside of the table, just enough to allow the bracket to move side-to-side.
- Adjust the bracket until the blade is parallel to the mitre gauge slot.
- Tighten the rear pivot bracket fasteners to 12.5–13.6 Nm (110–120 in-lbs).

#### Blade height adjustment (Fig. A)

The blade can be raised and lowered by turning the blade height adjustment wheel **6**.

Make sure the top three teeth of the blade are just breaking through the upper surface of the workpiece when sawing. This will ensure that the maximum number of teeth are removing material at any given time, thus giving optimum performance.

### Aligning Guard Assembly/Splitter to Blade (Fig. A, H)

- Remove the throat plate. Refer to **Remove Throat Plate**.
- Raise the blade to full depth of cut and 0° bevel angle.
- Locate the three small set screws **39** adjacent to the guard assembly lock shaft **38**. These screws will be used to adjust the guard assembly position.
- Lay a straight edge on the table against two blade tips. The splitter **13** should not touch the straight edge. If needed, loosen the two larger lock screws **41**.
- Adjust the small set screws **39** to move the splitter according to the position noted in step 4. Lay the straight edge on the opposite side of the blade and repeat adjustments as needed.
- Lightly tighten the two larger lock screws **41**.
- Place a square flat against the splitter to verify splitter is vertical and in-line with the blade.



- If needed, use the set screws to bring the splitter vertical with the square.
- Repeat steps 4 and 5 to verify position of splitter.
- Fully tighten the two larger lock screws **41**.
- Re-install and lock the throat plate **16**.

## Parallel Adjustment (Fig. A, I, J, O)

 **WARNING:** A misaligned fence, not parallel to the blade, increases the risk of kickback!

For optimum performance, the blade must be parallel to the rip fence. This adjustment has been made at the factory. To re-adjust:

### Position 1 Fence Alignment

- Install the fence in position 1 and unlock the rail lock lever **5**. Locate both locator pins **29** that support the fence on the front and rear rails.
- Loosen the rear locator pin screw and adjust the alignment of the fence in the groove until the fence face is parallel to the blade. Make sure you measure from the fence face to the front and back of the blade to ensure alignment.
- Tighten the locator screw and repeat on the left side of the blade.
- Check rip scale pointer adjustment (Fig. J).

### Position 2 Fence Alignment

- To align position 2 fence locator pins **29**, ensure position 1 pins have been aligned, refer to **Position 1 Fence Alignment**.
- Loosen the position 2 pins, then using the blade wrench holes as a guide for positioning, align the pins (Fig. O).
- Tighten the locator pins (front and rear).

## Adjusting the Rip Scale (Fig. A, J)

- Unlock the rail lock lever **5**.
- Set the blade at 0° bevel and move the fence in until it touches the blade.
- Lock the rail lock lever.
- Loosen the rip scale indicator screws **31** and set the rip scale indicator to read zero (0). Retighten the rip scale indicator screws. The yellow rip scale (top) reads correctly only when the fence is mounted on the right side of the blade and is in position 1 (for zero to 62 cm ripping) not the 82.5 cm rip position. The white scale (bottom) reads correctly only when the fence is mounted on the right side of the blade and in position 2 (for 20.3 cm to 82.5 cm ripping).

The rip scale reads correctly only when the fence is mounted to the right of the blade.

## Rail Lock Adjustment (Fig. A, K)

The rail lock has been factory-set. If you need to re-adjust, proceed as follows:

- Lock the rail lock lever **5**.
- On the underside of the saw, loosen the jam nut **33**.

- Tighten the hex rod **34** until the spring on the locking system is compressed creating the desired tension on the rail lock lever. Retighten the jam nut against the hex rod.
- Flip the saw over and check that the fence does not move when the lock lever is engaged. If the fence is still loose, tighten the spring further.

## Bevel Stop and Pointer Adjustment (Fig. L)

- Raise the blade fully by rotating the blade height adjustment wheel **6** clockwise until it stops.
- Unlock the bevel lock lever **7** by pushing it up and to the right. Loosen the bevel stop screw **36**.
- Place a square flat against the table top and against the blade between teeth. Ensure the bevel lock lever is in its unlocked, or up position.
- Using the bevel lock lever, adjust the bevel angle until the blade is flat against the square.
- Tighten the bevel lock lever by pushing it down.
- Turn the bevel stop cam **35** until it firmly contacts the bearing block. Tighten the bevel stop screw **36**.
- Check the bevel angle scale. If the pointer does not read 0°, loosen pointer screw **37** and move the pointer so it reads correctly. Retighten the pointer screw.
- Repeat at 45°, but do not adjust pointer.

## Mitre Gauge Adjustment (Fig. A)

To adjust mitre gauge **10** loosen knob, set to desired angle and tighten knob.

## Body and Hand Position

Proper positioning of your body and hands when operating the table saw will make cutting easier, more accurate and safer.



### WARNING:

- Never place your hands near the cutting area.
- Place your hands no closer than 150 mm from the blade.
- Do not cross your hands.
- Keep both feet firmly on the floor and maintain proper balance.

## Prior to Operation



### WARNING:

- Install the appropriate saw blade. Do not use excessively worn blades. The maximum rotation speed of the tool must not exceed that of the saw blade.
- Do not attempt to cut excessively small pieces.
- Allow the blade to cut freely. Do not force.
- Allow the motor to reach full speed before cutting.

## OPERATION

### Instructions for Use



**WARNING:** Always observe the safety instructions and applicable regulations.



**WARNING:** To reduce the risk of serious personal injury, turn tool off and disconnect tool from power source before making any adjustments or removing/installing attachments or accessories. An accidental start-up can cause injury.

The attention of UK users is drawn to the "woodworking machines regulations 1974" and any subsequent amendments. Ensure the machine is placed to satisfy your ergonomic conditions in terms of table height and stability. The machine site shall be chosen so that the operator has a good overview and enough free surrounding space around the machine that allows handling of the workpiece without any restrictions.

To reduce effects of increased vibration, make sure the environment is not too cold, the machine and accessory are well maintained and the workpiece size is suitable for this machine.

**WARNING:**

- Ensure the machine is placed to satisfy ergonomic conditions in terms of table height and stability. The machine site shall be chosen so that the operator has a good overview and enough free surrounding space around the machine that allow handling of the workpiece without any restrictions.
- Install the appropriate saw blade. Do not use excessively worn blades. The maximum rotation speed of the tool must not exceed that of the saw blade.
- Do not attempt to cut excessively small pieces.
- Allow the blade to cut freely. Do not force.
- Allow the motor to reach full speed before cutting.
- Make sure all locking knobs and clamp handles are tight.
- Never place either hand in the blade area when the saw is connected to the electrical power source.
- Never use your saw for freehand cuts!
- Do not saw warped, bowed or cupped workpieces. There must be at least one straight, smooth side to go against the rip fence or mitre fence.
- Always support long workpieces to prevent kickback.
- Do not remove any cut-offs from the blade area while the blade is running.

**Switching On and Off (Fig. M)**

The on/off switch **8** of your saw bench offers multiple advantages:

- No-volt release function: should the power be shut off for any reason, the switch has to be deliberately reactivated.
- To switch the machine on, press the green start button.
- To switch the machine off, press the red stop button.

**Lock Off Feature Instructions**

A cover above the switch folds down for insertion of a padlock to lock the saw off. A padlock with a maximum diameter of 6.35 mm and minimum clearance of 76.2 mm is recommended.

**Rip Fence Operation (Fig. N–P)****Rail lock lever**

The rail lock lever **5** locks the fence in place preventing movement during cutting. To lock the rail lever, push it down and toward the rear of the saw. To unlock, pull it up and toward the front of the saw.

**NOTE:** When ripping, always lock the rail lock lever.

**Work Support Extension / Narrow Ripping Fence**

Your table saw is equipped with a work support extension to support work that extends beyond the saw table.

To use the narrow ripping fence in the work support position, rotate it from its stored position as shown in Figure O, and slide the pins into the lower sets of slots **27** on both ends of the fence.

To use the narrow ripping fence in the narrow ripping position, snap the pins into the upper sets of slots **28** on both ends of the fence. This feature will allow 51 mm of extra clearance to the blade. Refer to Figure P.

**NOTE:** Retract the work support extension or adjust to narrow rip fence position whenever working over the table.

**NOTE:** When using the narrow ripping fence, subtract 51 mm from the indicated rip scale reading.

**Fine Adjustment Knob**

The fine adjustment knob **4** allows smaller adjustments when setting the fence. Before adjusting, be sure the rail lock lever is in its up or unlocked, position.

**Rip Scale Pointer**

The rip scale pointer will need to be adjusted for proper performance of the rip fence if the user switches between thick and thin kerf blades. The rip scale pointer only reads correctly when the fence is installed in position 1 or 2 to the right side of the blade. When using the narrow ripping fence for narrow ripping (not in work support position), subtract 51 mm from the indicated rip scale reading. See **Adjusting the Rip Scale** under **Adjustments**.

**BASIC SAW CUTS****Through-Cutting Operations**

**WARNING:** Use blade guard assembly for all through-cutting operations.

**Ripping (Fig. A, B, Q, R)**

**WARNING:** Sharp edges.

1. Set the blade to 0°.
2. Install the rip fence and lock the rip fence latch **18** (Fig. A).
3. Raise the blade until it is about 3 mm higher than the top of the workpiece. Adjust the height of the upper blade guard as necessary.
4. Adjust the position of the fence and lock the rail lock lever **5**, refer to **Rip Fence Operation**.

5. Hold the workpiece flat on the table and against the fence. Keep the workpiece away from the blade.
6. Keep both hands away from the path of the blade (Fig. Q).
7. Switch the machine on and allow the blade to reach full speed.
8. Slowly feed the workpiece underneath the guard, keeping it firmly pressed against the rip fence. Allow the teeth to cut, and do not force the workpiece through the blade. The blade speed should be kept constant.
9. Always use a push stick **21** when working close to the blade (Fig. R).
10. After completing the cut, switch the machine off, allow the blade to stop and remove the workpiece.

### **WARNING:**

- Never push or hold the "free" or cut-off-side of the workpiece.
- Do not cut excessively small workpieces.
- Always use a push stick when ripping small workpieces.

## Bevel Cuts (Fig. A)

1. To set the required bevel angle, rotate the bevel lock lever **7** by pushing it up and to the right.
2. To set to desired angle, rotate the lever by pushing it down and to the left to lock in place.
3. Proceed as for ripping.

## Cross-Cutting and Bevel Crosscutting (Fig. Q)

1. Remove the rip fence and install the mitre gauge in the desired slot.
2. Lock the mitre gauge at 0°.
3. Proceed as for ripping.

## Mitre Cuts (Fig. A)

1. Set the mitre gauge **10** to the required angle.

**NOTE:** Always hold the workpiece tightly against the face of the mitre gauge.

2. Proceed as for ripping.

## Compound Mitre

This cut is a combination of a mitre and a bevel cut. Set the bevel to the angle required and proceed as for a cross-cut mitre.

## Support for Long Pieces

- Always support long pieces.
- Support long workpieces using any convenient means such as saw-horses or similar devices to keep the ends from dropping.

## Non-Through-Cutting (Grooving and Rabbeting)

 **WARNING:** Remove the blade guard assembly **11** and install the non-through-cutting riving knife **52** for non-through-cutting operations. Use featherboards for all non-through-cutting operations where the blade guard

assembly, anti-kickback assembly and riving knife cannot be used.

Instructions in the **Ripping, Crosscutting, Bevel Crosscutting, Mitreing, and Compound Mitreing** sections are for cuts made through the full thickness of the material. The saw can also perform non-through cuts to form grooves or rabbets in the material.

### Non-Through-Ripping (Fig. D, U)

 **WARNING:** A rip fence should **ALWAYS** be used for ripping operations to prevent loss of control and personal injury. **NEVER** perform a ripping operation freehand. **ALWAYS** lock the fence to the rail.

 **WARNING:** When bevel ripping and whenever possible, place the fence on the side of the blade so that the blade is tilted away from the fence and hands.

 **WARNING:** Keep hands clear of the blade. With non-through-cutting the blade is not always visible during the cut, so increased caution is necessary to ensure hands are clear of the blade.

 **WARNING:** Use a push stick to feed the workpiece if there are 51–152 mm between the fence and the blade. Use a narrow ripping fence feature and push block to feed the workpiece if there are 51 mm or narrower between the fence and the blade.

1. Remove the blade guard assembly **11** and install the non-through-cutting riving knife **52** (Fig. D). Refer to: **Mounting the Blade Guard Assembly/Riving Knife**.
2. Lock the rip fence by pressing the rail lock lever down. Remove the mitre gauge.
3. Raise the blade to the desired cut depth.
4. Hold the workpiece flat on the table and against the fence. Keep the workpiece about 25.4 mm away from the blade.

 **WARNING:** The workpiece must have a straight edge against the fence and must not be warped, twisted or bowed. Keep both hands away from the blade and away from the path of the blade. See proper hand position in Figure U.

5. Turn the saw on and allow the blade to come up to speed. Both hands can be used in starting the cut. When there are approximately 305 mm left to be ripped, use only one hand, with your thumb pushing the material, your index and second finger holding the material down and your other fingers hooked over the fence. Always keep your thumb along side your first two fingers and near the fence.
6. Keeping the workpiece against the table and fence, slowly feed the workpiece rearward all the way through the saw blade. Continue pushing the workpiece until it is clear of the blade guard assembly and it falls off the rear of the table. Do not overload the motor.
7. Never try to pull the workpiece back with the blade turning. Turn the switch off, allow the blade to stop and slide the workpiece out.
8. When sawing a long piece of material or a panel, always use a work support. A sawhorse, rollers, or out feed assembly provides adequate support for this purpose. The work

support must be at the same height or slightly lower than the saw table.

### Non-Through-Ripping Small Pieces (Fig. A)

It is unsafe to rip small pieces. It is not safe to put your hands close to the blade. Instead, rip a larger piece to obtain the desired piece. When a small width is to be ripped and the hand cannot be safely put between the blade and the rip fence, use one or more push sticks. A push stick **21** is included with this saw, attached to the rip fence. Use the push stick(s) to hold the workpiece against the table and fence, and push the workpiece fully past the blade.

### Non-Through-Bevel Ripping (Fig. V)

This operation is the same as non-through-cut ripping except the bevel angle is set to an angle other than zero degrees. For proper hand position, Refer to Figure V.



**WARNING:** Before connecting to power source or operating the saw, always inspect the riving knife for proper alignment and clearance with saw blade. Check alignment after each change of bevel angle.

### Non-Through-Crosscutting (Fig. W)



**WARNING: NEVER** use rip fence in combination with mitre gauge.



**WARNING:** To reduce the risk of injury, NEVER use the fence as a guide or length stop when crosscutting.



**WARNING:** When using a block as a cut-off gauge, the block must be at least 19 mm thick and is very important that the rear end of the block be positioned so the workpiece is clear of the block before it enters the blade to prevent contact with blade resulting in a thrown workpiece and possibly injury.

1. Remove the rip fence and place the mitre gauge in the desired slot.
2. Adjust the blade height to the desired cut depth.
3. Hold the workpiece firmly against the mitre gauge **10** with the path of the blade in line with the desired cut location. Keep the workpiece an inch or so in front of the blade. KEEP BOTH HANDS AWAY FROM THE BLADE AND THE PATH OF THE BLADE (Fig. W).
4. Start the saw motor and allow the blade to come up to speed.
5. While using both hands to keep the workpiece against the face of the mitre gauge, and holding the workpiece flat against the table, slowly push the workpiece through the blade.
6. Never try to pull the workpiece with the blade turning. Turn the switch off, allow the blade to stop, and carefully slide the workpiece out.

### Non-Through-Bevel Crosscutting

This operation is the same as crosscutting except that the bevel angle is set to an angle other than 0°.



**WARNING:** Before connecting to power source or operating the saw, always inspect the riving knife for

proper alignment and clearance with saw blade. Check alignment after each change of bevel angle.

### Non-Through-Mitreing (Fig. W)

This operation is the same as crosscutting except the mitre gauge is locked at an angle other than 0°. Hold the workpiece FIRMLY against the mitre gauge **10** and feed the workpiece slowly into the blade (to prevent the workpiece from moving).

#### Non-Through-Mitre Gauge Operation

To set your mitre gauge:

1. Loosen the mitre gauge lock knob **46**.
2. Move the mitre gauge to the desired angle.
3. Tighten the mitre gauge lock knob.

#### Non-Through-Compound Mitreing

This is a combination of non-through-bevel crosscutting and non-through-mitreing. Follow the instructions for both non-through-bevel crosscutting and non-through-mitreing.



### Dust extraction (Fig. A, AA)

The machine is provided with a dust exhaust port **14** at the rear of the machine suitable for use with dust extraction equipment featuring 57/65 mm nozzles. Supplied with the machine is a reducer port for use of dust extraction nozzles of 34–40 mm diameter.

Supplied with the machine is a reducer port for use with the DEWALT AirLock system (DWW9000-XJ).

The blade guard assembly also features a dust exhaust port for 35mm nozzles or direct attachment to the DEWALT AirLock (DWW9000-XJ).

Dust from materials such as lead-containing coatings and some wood types, can be harmful to one's health. Breathing-in the dust can cause allergic reactions and/or lead to respiratory infections of the user or bystanders.

Certain dust, such as oak or beech dust, is considered carcinogenic, especially in connection with wood-treatment additives.

Observe the relevant regulations in your country for the materials to be worked.

The vacuum cleaner must be suitable for the material being worked.

When vacuuming dry dust that is especially detrimental to health or carcinogenic, use dust class M vacuum cleaner.

The blade guard assembly also features a dust exhaust port for 35 mm nozzles (M class vacuum).

- During all operations, connect a dust extraction device designed in accordance with the relevant regulations regarding dust emission.
- Ensure that the dust extraction hose in use is suitable for the application and material being cut. Ensure proper hose management.
- Be aware that man-made materials such as chipboard or MDF produce more dust particles during cutting than natural timber.

## Storage (Fig. B, X–Z)

Store the machine in a safe manner when not being used. The storage location must be dry and lockable. This prevents the machine from storage damage, and from being operated by untrained persons.

1. Attach push stick **21** to fence.
2. Remove blade guard assembly. See **To Remove Blade Guard Assembly**. Slide blade guard assembly **11** into holder as shown, then turn lock knob 1/4 to lock in place. Refer to Figure X.
3. Slide blade wrenches **20** into pocket until yellow button aligns with hole to secure in place, refer to Figure B.
4. Insert guide bar of mitre gauge into pocket until it bottoms out.
5. Wrap cord in this location **43**. Refer to Figure Z.
6. To store fence, snap work support in stored position. Remove fence from rails. Reattach fence upside down on left side of saw, refer to Figure Y. DO NOT hook locator slots on left side fence locator screws. These screws will align with clearance pocket on fence as shown. Close the rip fence latches **18** to secure.
7. Non-through cutting riving knife **52** can be installed in the saw (working position) or stored along with the blade guard assembly. Refer to Figure B.

## Transporting (Fig. A, B)

Before transportation following has to be done:

- Wrap cord
- Turn the blade height adjustment wheel **6** in anticlockwise direction until the teeth of the saw blade are positioned below the saw table. Lock the bevel lock lever **7**.
- Slide the fence rails completely inward and fix it by rail lock lever **5**.
- Always carry the machine using the designated handles **50**, refer to Figures A and B.

 **WARNING:** Always transport the machine with the upper blade guard fitted.

## MAINTENANCE

Your DeWALT power tool has been designed to operate over a long period of time with a minimum of maintenance. Continuous satisfactory operation depends upon proper tool care and regular cleaning.

 **WARNING:** To reduce the risk of serious personal injury, turn tool off and disconnect tool from power source before making any adjustments or removing/installing attachments or accessories. An accidental start-up can cause injury.



## Lubrication (Fig. T)

The motor and bearings require no additional lubrication. If raising and lowering the blade becomes difficult, clean and grease the height adjustment screws:

1. Unplug the saw from power source.
2. Turn the saw on its side.
3. Clean and lubricate the height adjustment screw threads **42** on the underside of this saw as shown in Figure T. Use general purpose grease.





## Cleaning (Fig. A, S)

 **WARNING:** To reduce the risk of serious personal injury, turn unit off and disconnect machine from power source before cleaning. An accidental start-up can cause injury.

 **WARNING:** Blow dirt and dust out of the main housing with dry air as often as dirt is seen collecting in and around the air vents. Wear approved eye protection and approved dust mask when performing this procedure.

 **WARNING:** Never use solvents or other harsh chemicals for cleaning the non-metallic parts of the tool. These chemicals may weaken the materials used in these parts. Use a cloth dampened only with water and mild soap. Never let any liquid get inside the tool; never immerse any part of the tool into a liquid.

 **WARNING:** To reduce the risk of injury, regularly clean the table top.

 **WARNING:** To reduce the risk of injury, regularly clean the dust collection system.

The blade guard assembly **11** and throat plate must be placed in position before operating the saw.

Before use, carefully inspect upper and lower blade guards as well as the dust extraction tube to determine that it will operate properly. Ensure that chips, dust or work piece particles cannot lead to blockage of one of the functions.

In case workpiece fragments are jammed between saw blade and guards, disconnect the machine from the power supply and follow the instructions given in section **Mounting the saw blade**. Remove the jammed parts and reassemble the saw blade.

Keep the ventilation slots clear and regularly clean the housing with a soft cloth.

Regularly clean the dust collection system:

1. Unplug the saw.
2. Turn the saw on its side, so the bottom, open part of the unit is accessible.
3. Open the dust access door **44** shown in Figure S loosening the two screws and then by pressing the side clips **45** toward each other. Clean out the excess dust, and re-secure by pushing the side clips completely into place then tightening the lock screws.

## Optional Accessories



**WARNING:** Since accessories, other than those offered by DeWALT, have not been tested with this product, use of such accessories with this tool could be hazardous. To reduce the risk of injury, only DeWALT recommended accessories should be used with this product.

Consult your dealer for further information on the appropriate accessories.

Replace blade guard when worn. Contact your local DeWALT service centre for details on a blade guard replacement.

**SAW BLADES(FOR B1):** ALWAYS USE 250 mm noise reduced saw blades with 25.4 mm arbour holes. Blade speed rating must be at least 5000 RPM. Never use a smaller diameter blade. It will not be guarded properly.

**SAW BLADES(FOR IN/A9):** ALWAYS USE 254 mm noise reduced saw blades with 25.4 mm arbour holes. Blade speed rating must be at least 5000 RPM. Never use a smaller diameter blade. It will not be guarded properly.

### BLADE DESCRIPTIONS(B1)

APPLICATION	DIAMETER	TEETH
<b>Construction Saw Blades</b> ( <i>fast rip</i> )		
General Purpose	250 mm	24
Fine Crosscuts	250 mm	40
<b>Woodworking Saw Blades</b> ( <i>provide smooth, clean cuts</i> )		
Fine crosscuts	250 mm	60

### BLADE DESCRIPTIONS(IN/A9)

APPLICATION	DIAMETER	TEETH
<b>Construction Saw Blades</b> ( <i>fast rip</i> )		
General Purpose	254 mm	24
Fine Crosscuts	254 mm	40
<b>Woodworking Saw Blades</b> ( <i>provide smooth, clean cuts</i> )		
Fine crosscuts	254 mm	60

Consult your dealer for further information on the appropriate accessories.

- DWE74911 Rolling Table Saw Stand
- DWE74912 Scissor Leg Stand

## Protecting the Environment



Separate collection. Products and batteries marked with this symbol must not be disposed of with normal household waste.

Products and batteries contain materials that can be recovered or recycled reducing the demand for raw materials. Please recycle electrical products and batteries according to local provisions. Further information is available at [www.2helpU.com](http://www.2helpU.com).

# 台锯

## DWE7492

### 恭喜!

感谢您选购 DeWALT 工具。凭借多年的产品开发和创新能力，DeWALT 已经成为专业电动工具用户最可靠的合作伙伴之一。

### 技术参数

		DWE7492
电压	伏特 <sub>交流</sub>	220
电机功率 (输入)	瓦	2000
电机功率 (输出)	瓦	1200
空载转速	转/分	4800
锯片直径	毫米	254
锯片孔	毫米	25.4
锯片厚度	毫米	2.0
分料刀厚度	毫米	2.2
90° 锯深	毫米	79
45° 锯深	毫米	57
斜角角度	°	45–90
最大斜角角度	°	45–90
斜接角度	°	30–90
纵向切割能力	毫米	825
总尺寸	毫米	680 x 650 x 330
重量	千克	26.5

### 定义: 安全指南

下列定义描述了各标志术语的严重程度。请仔细阅读本手册，并注意这些标志。



**危险:** 表示存在紧急危险情况，如果不加以避免，将导致死亡或严重伤害。



**警告:** 表示存在潜在的危险情况，如果不加以避免，可能导致死亡或严重伤害。



**警示:** 表示存在潜在危险情况，如果不加以避免，可能导致轻度或中度伤害。

**注意:** 表示存在不涉及人身伤害的情况，如果不加以避免，可能导致财产损失。



表示存在触电风险。



表示存在火灾风险。

### 电动工具一般安全警告



**警告:** 请阅读随该电动工具提供的所有安全警告、指示、图解和规定。不了解以下所列所有指示可能会导致电击、着火和/或严重伤害。

### 请妥善保存所有警告和说明

#### 以备将来查阅

警告中的术语“电动工具”是指电源供电式（有线）或电池供电式（无线）电动工具。

#### 1) 工作场所安全

- 保持工作场地清洁和明亮。杂乱或阴暗的地方容易引发事故。
- 不要在易爆环境中操作电动工具，如有易燃液体、气体或粉尘的环境。电动工具产生的火花可能会点燃粉尘或气体。
- 操作电动工具时，切勿让儿童和闲人靠近。注意力分散会导致您放松控制。

#### 2) 电气安全

- 电动工具插头必须与同规格的插座匹配。禁止以任何方式改装插头。需接地的电动工具不能使用任何转换插头。使用未经改装的插头和与之匹配的插座可以降低触电的风险。
- 避免身体接触接地表面，如管道、散热片、炉灶和冰箱等。身体接地会增加触电的风险。
- 请勿将电动工具暴露在雨中或潮湿的环境中。电动工具进水会增加触电的风险。
- 请勿滥用电线。请勿使用电线搬运、拉动电动工具或拔出插头。保持电线远离热源、油、锐边或运动部件。电线受损或缠结会增加触电风险。
- 在户外操作电动工具时，请使用适合户外使用的延长线。采用适合户外使用的电线可降低触电风险。
- 如果必须在潮湿场合使用电动工具，请使用漏电保护装置(RCD)。使用漏电保护器可减少触电的危险。

#### 3) 人身安全

- 保持警觉。操作电动工具时，关注所从事的操作并保持清醒。不要在疲倦，或受到药物、酒精或治疗的影响下使用电动工具。操作电动工具时片刻的注意力分散可能会导致严重的人身伤害。
- 使用个人防护装备。始终佩戴护目镜。在适用情况下使用防护装备（如防尘口罩、防滑安全鞋、安全帽或听力保护设备等）可减少人身伤害。
- 避免意外启动。在连接电源和/或电池组之前，以及拿起或搬动工具之前，请确保开关处于关闭位置。搬动电动工具时把手指放在开关上，或开关处于接通状态时插入插头均可引发危险。
- 在启动电动工具之前，先取下所有调节钥匙或扳手。连接在电动工具旋转部件上的扳手或调整键可能导致人身伤害。
- 请勿伸手越过电动工具。时刻注意脚下和身体平衡。这样才能在意外情况下更好地控制电动工具。
- 正确着装。切勿穿宽松的衣服或佩戴首饰。让您的头发、衣服和手套远离运动部件。宽松的衣服、首饰或长发可能会被运动部件缠住。

- g) 如果提供了与排屑装置和集尘设备连接用的装置，请确保这些装置连接完好且使用得当。使用集尘设备可减少与粉尘相关的危害。
- h) 请勿因频繁使用工具而产生的熟练感而过于自信，导致忽略工具安全原则。任何不谨慎的动作都可能会在一秒钟之内造成严重伤害。

#### 4) 电动工具的使用和保养

- a) 使用电动工具时请勿用力过猛。根据用途选用适当的电动工具。适当的电动工具在设计速率下能获得更好的工作效果，而且更加安全。
- b) 如果开关不能接通或切断工具电源，则不能使用该电动工具。无法用开关控制的电动工具是危险的，必须进行修理。
- c) 进行任何调整、更换配件或存放电动工具之前，请从电源上拔掉插头和/或从电动工具上卸下电池组。这种预防性安全措施能降低电动工具意外启动的风险。
- d) 请将闲置的电动工具存放在儿童无法触及的地方，并且不能允许不熟悉电动工具或对本说明书不了解的人员操作电动工具。让未经培训的用户操作电动工具是很危险的。
- e) 维护电动工具和配件。检查运动部件的偏差或卡住、零件破损情况和影响电动工具运行的其它条件。如有损坏，必须在使用前对电动工具进行维修。许多事故都是因电动工具维护不良而导致的。
- f) 保持刀具锋利清洁。妥善维护的锋利刀具在操作时不容易卡住，并且更容易控制。
- g) 使用电动工具、配件以及工具刀头等时，请遵循这些说明并考量具体的工作条件以及要执行的工作。将电动工具用于设计之外的操作时可能会发生危险。
- h) 保持手柄和抓握表面干燥、清洁，无油和油脂。光滑的手柄和抓握表面无法在意想不到的情况下安全地操作和控制工具。

#### 5) 检修

- a) 将您的电动工具交由合格的维修人员，只能使用相同的替换部件进行更换。这样可以确保电动工具的安全性。

### 适用于所有台锯的安全说明

#### 1) 防护相关警告

- a) 保持防护罩就位。防护罩必须处于正常工作状态并正确安装。松动、损坏或无法正常工作的防护罩必须进行修理或更换。
- b) 每次进行直切操作时，均应使用锯片防护罩、分料刀和防反撞爪。对于直切操作，锯片将完全切穿工件的整个厚度，安装防护罩和其他安全装置将有助于降低受伤的风险。
- c) 完成需要移除防护罩、分料刀和/或防反撞爪的操作（例如嵌接切口）后，请立即重新连接防护系统。防护罩、分料刀和防反撞爪有助于降低受伤风险。
- d) 确保在打开工具电源前，锯片不接触防护罩、分料刀或工件。意外接触这些物品与锯片可能会导致危险情况。
- e) 按照本说明手册中的说明调整分料刀。不正确的间距、定位和对齐方式会使分料刀在降低反冲的可能性时无法发挥效力。

- f) 如需使分料刀和防反撞爪正常工作，必须将其与工件相结合。当切割工件太短而无法与分料刀和防反撞爪结合时，分料刀和防反撞爪将无法发挥应有效力。在这种情况下，分料刀和防反撞爪不能防止反冲。
- g) 使用与分料刀适合的锯片。为了使分料刀正常工作，锯片的直径必须与相应的分料刀相匹配，并且锯片的主体必须比分料刀的厚度薄，锯片的切割宽度必须大于分料刀的厚度。

#### 2) 切割程序安全指示

- a)  **危险：切勿将手指或手放在锯片附近或与锯片对齐。**疏忽或滑倒可能会使您的手伸向锯片，并导致严重的人身伤害。
- b) 仅沿与旋转方向相反的方向将工件送入锯片或切割器。以与锯片在锯台上方旋转相同的方向送入工件可能会导致工件和您的手被拉入锯片。
- c) 纵向切割时切勿使用斜接计送入工件，使用斜接计进行横切时，切勿使用纵切挡板作为长度止挡。同时使用纵切挡板和斜接计对工件进行导向，将增加锯片粘附和反冲的可能性。
- d) 纵向切割时，始终在挡板和锯片之间对工件施加推送力。当挡板和锯片之间的距离小于 150 毫米时，请使用推杆；如果该距离小于 50 毫米，请使用推块。“工作帮助”设备可使您的手与锯片保持安全距离。
- e) 仅使用制造商提供或根据说明构造的推杆。该推杆可以使手与锯片保持足够的距离。
- f) 切勿使用损坏或断裂的推杆。损坏的推杆可能会断裂，导致您的手滑入锯片。
- g) 请勿徒手执行任何操作。始终使用纵切挡板或斜接计来定位和引导工件。“徒手”是指用您的双手支撑或引导工件，而不是使用纵切挡板或斜接计。徒手操作会导致无法对准，卡住和反冲。
- h) 切勿将手置于旋转的锯片周围或上方。伸入工件可能会导致意外接触活动的锯片。
- i) 在锯台的后部和/或侧面提供辅助工件支撑，以使较长和/或较宽的工作保持水平。长和/或宽的工作有可能在锯台边缘枢转，从而导致控制失灵，锯片粘附和反冲。
- j) 以均匀的速度进给工件。请勿弯曲或扭曲工件。如果发生卡住现象，请立即关闭工具，拔出工具插头，然后清除卡住物体。锯片被工件卡住会导致反冲或使电机停转。
- k) 锯运行时，切勿清除碎屑。物料可能会滞留在挡板之间或锯片防护罩内部，并且锯片会将您的手指拉入锯片。关闭锯，并等到锯片停止后再清除残余物料。
- l) 抓取厚度小于 2 毫米的工件时，请使用辅助挡板以与桌面进行接触。较薄的工件可能会楔入纵切挡板下方并产生反冲。

#### 3) 反冲原因和相关警告

反冲是指由于锯片被挤压，卡住或工件未对准锯片的切割线或工件的一部分粘在锯片与纵切挡板或其他固定物体之间而引起的工件突然反应。

在反冲过程中，最常见的是，工件由锯片的后部从锯台上抬起并被推向操作员。

反冲是由于使用不当和/或不正确的操作程序或条件造成的。适当采取下列预防措施，可避免反冲现象：



- a) 切勿站在与锯片对齐的位置。始终将身体置于挡板和锯片的同一侧。反冲可将工件高速推向站在前面并与锯片成一直线的任何人。
- b) 切勿伸过锯片的上方或后部拉扯或支撑工件。可能意外接触锯片，或者反冲可能会将手指拖入锯片。
- c) 切勿将切下的工件紧紧地按在旋转的锯片上。将切下的工件压在锯片上会产生粘卡情况和反冲。
- d) 将挡板对准锯片。未对准的挡板会将工件夹在锯片上，并产生反冲。
- e) 进行非直通切割（例如嵌接切口）时，请使用靠板将工件导向锯台和挡板。发生反冲时，靠板有助于控制工件。
- f) 支撑好大型板材将卡锯和反冲的风险最小化。大型板材容易因自身的重量下垂。必须在悬于桌面上方的整块板材下面提供支撑物件。
- g) 切割扭曲、打结、翘曲或没有直边的工件时，请特别注意用斜接计或沿挡板引导工件。翘曲、打结或扭曲的工件是不稳定的，并且会导致锯缝中心与锯片无法对齐，卡住和反冲。
- h) 切勿切割数量多于一个的工件，无论是垂直还是水平堆叠。锯片可能会抓起一个或多个工件并引起反冲。
- i) 如果锯片需要在插入工件时重新启动，请把锯片与锯缝中心对准，确保锯齿没有卡在材料里。如果锯片被卡住，可能会抬起工件并在重新启动锯片时引起反冲。
- j) 保持锯片清洁，锋利并且已进行完整设置。切勿使用弯曲的锯片或锯齿破裂或折断的锯片。锋利且正确设置的锯片可最大程度地减少卡住，失速和反冲。

#### 4) 台锯操作程序警告

- a) 拆下锯台附件，更换锯片或对分料刀，防反撞爪或锯片防护罩进行调整，以及无人看管机器时，请关闭台锯并断开电源线。采取预防措施可以避免事故的发生。
- b) 切勿将运行中的台锯闲置在一旁。请将工具关闭，并且在工具完全停止之前，请勿将工具闲置在一旁。无人看管的台锯将产生无法控制的危险。
- c) 将台锯放置在光线充足且水平的区域，以保持良好的直立和平衡状态。应将其安装在有足够空间轻松处理工件尺寸的区域。狭窄，黑暗的区域以及不平坦的湿滑地板都可能引发事故。
- d) 经常清洁并从锯台和/或集尘装置下面清除锯末。积累的锯末是可被点燃的，并且可能自燃。
- e) 台锯必须被固定住。未正确固定的台锯可能会移动或翻倒。
- f) 在打开台锯之前，请从锯台上移除工具和木屑等。分心或潜在的卡住情况可能产生危险。
- g) 切记使用的锯片要具有正确尺寸和形状的轴心孔（菱形或圆形）。与锯台设备不匹配的锯片将出现偏心运动，导致失控。
- h) 切勿使用损坏或不正确的锯片安装装置，例如法兰、锯片垫圈，螺栓或螺母。这些安装装置是为您设计的，以确保其安全操作和最佳性能。
- i) 切勿站在台锯上，请勿将其用作脚踏凳。如果工具倾斜或意外触及切割工具，可能会造成严重伤害。
- j) 确保锯片已安装为沿正确方向旋转。请勿在台锯上使用砂轮，钢丝刷或研磨轮。锯片安装不当或使用不推荐的配件可能会造成严重伤害。

## 台锯附加安全规范



**警告：**切割塑料，树皮涂层木材和其他材料可能导致熔化的材料积聚在锯片尖端和锯片主体上，可能增加锯片在切割时过热和卡住的风险。

- 请避免采取不适宜的姿势，以免突然滑倒并可能导致手移入锯片。
- 锯片旋转时，请勿尝试在锯台上的锯片附近取回材料。
- 切勿用任何一只手伸入切削工具的后部或周围以压下工件。
- 保持手臂，手和手指远离锯片，以防止严重伤害。
- 使用适合应用的推杆将工件推过锯。推杆通常是一种自制的木制或塑料制的杆，应在工件的尺寸或形状可能需要您将手放置在离锯片 152 毫米的范围之内时使用。
- 使用压紧装置、夹具，固定装置或羽毛板来帮助引导和控制工件。与工具一起使用的配件可从当地经销商或授权服务中心购得，但需要额外付费。
- 请勿进行纵向切割，横向切割或任何徒手操作。
- 锯片旋转时，切勿将手伸至锯片周围或上方。
- 稳定性。使用前，请确保台锯牢固地安装在安全的表面上并且不能移动。
- 台锯只能放置在水平且稳定的表面上。工作区域应没有障碍物且无绊倒危险。请勿将任何材料或工具靠在锯上。
- 切勿切割金属，水泥板或砖石。切割某些人造材料需遵循台锯的切割特殊说明。始终遵循制造商的建议。这可能会导致台锯受损和人身伤害。
- 请勿安装金刚石砌石锯片，并尝试将台锯用作湿锯。
- 必须始终将适当的针板锁定在适当的位置，以减少工件抛出和可能受伤的风险。
- 处理锯片时戴上手套。
- 使用正确的锯片进行预期的操作。锯片必须朝向锯的前方旋转。始终牢牢拧紧锯片杆螺母。使用前，请检查锯片是否破裂或缺齿。请勿使用破损或变钝的锯片。
- 在未关闭机器并断开工具与电源的连接之前，切勿尝试释放失速的锯片。如果工件或切割件被卡在锯片防护罩组件内，请关闭锯并等待锯片停下来，然后再提起锯片防护罩组件并卸下该部件。
- 切勿在工件紧贴锯片的情况下启动机器，以减少抛出工件和造成人身伤害的风险。
- 请勿将身体的任何部分与锯片对齐。否则可能会造成人身伤害。站在锯片的任一侧。
- 机器运行时，切勿在工作台/工作区上进行布局，组装或设置工件。突然打滑可能会导致手移入锯片。可能会导致严重伤害。
- 切勿在锯运行时进行任何调整，例如重新设置或拆除挡板，斜角锁定调整或锯片高度调整。
- 离开机器前请清洁工作台/工作区。将开关锁定在“OFF”位置，并断开工具与电源的连接以防止未经授权的使用。
- 在切割之前始终锁定挡板和斜角调整。
- 避免使锯片尖端过热。让物料移动并与挡板平行。请勿强行将工件伸入锯片。
- 如果切割塑料，请避免熔化塑料。
- 请勿在没有支撑的地方放置长板（或其他工件），以免板的弹簧使其在工作台上移动，从而导致失控和可能的伤害。根据工件的大小和需要执行的操作类型为工件提供适当的支撑。将工件牢牢地靠在挡板上并向上下压在桌子表面上。

- 如果该锯发出不熟悉的声音或振动过大，请立即停止操作，关闭装置并断开工具与电源的连接，直到发现问题为止。如果无法确定问题根源，请联系 DeWALT 工厂服务中心，DeWALT 授权服务中心或其他合格的服务人员。
- 在按照说明完全组装和安装之前，请勿操作本机器。机器组装不正确会导致严重伤害。
- 切勿试图切割一堆散落的材料，这些材料可能会导致失控或反冲。对所有材料进行安全支撑。

## 锯片

- **警告：**为了最大程度地减少反冲的风险并确保正确的切割，分流器和分料刀必须适用于所用锯片的厚度。如果使用其他锯片，请检查锯片或锯片包装上标记的锯片主体（板）厚度和锯片切缝（切口）宽度。分流器和分流刀的厚度必须大于锯片厚度且小于切缝宽度。
- 请勿使用尺寸不符合**技术参数**中介绍的锯片。请勿使用任何垫圈将锯片安装到主轴上。如果打算用于木材和类似材料，请仅使用本手册规定的、符合 EN847-1 要求的锯片。
- 请考虑使用特殊设计的降噪锯片。
- 请勿使用高碳钢 (HS) 锯片。
- 请勿使用破裂或损坏的锯片。
- 请确保所选的锯片适用于要切割的材料。
- 处理锯片和粗糙材料时，请始终佩戴手套。适当时，应将锯片放在固定器中。

## 剩余风险

使用斜切锯时具有下列固有风险：

- 接触旋转部件造成的伤害

尽管遵守了相关的安全法规并采用了安全装备，某些其他风险仍然是无法避免的。这些风险包括：

- 听力损伤。
- 旋转锯片的未遮盖部件造成的事故风险。
- 双手未受保护时更换锯片导致受伤的风险。
- 打开防护罩时夹伤手指的风险。
- 锯切木材，尤其是橡木、山毛榉与中密度纤维板时，吸入粉尘导致的健康危害。

以下因素会影响工作噪音：

- 切割的材料
- 锯片的类型
- 进刀力度
- 机器维护

以下因素会影响所暴露的灰尘：

- 锯片磨损
- 集尘器气流速度低于 20m/s
- 工件未准确操控

## 电气安全

电机只适用一种工作电压。请务必检查电源电压是否与铭牌上的电压一致。



您的得伟工具依据 IEC62841 标准设置双重绝缘，因此无须接地线。



**警告：**220V 装置必须通过故障保险隔离变压器操作，在初级绕组和次级绕组之间使用接地屏蔽。

如果电源线损坏，必须仅通过 DeWALT 或授权服务机构进行更换。

**注：**该设备用于连接用户电源接口（电源服务箱）上最大允许系统阻抗  $Z_{max}$  为 0.28Ω 的电源系统。用户必须确保该设备仅连接到满足上述要求的电源系统。如有必要，用户可以向公共电源公司询问接口点处的系统阻抗。

## 使用延长线

如需使用延长电缆，请使用与本工具的输入功率（见**技术参数**）匹配的经验检验 3 芯延长线。最小导体尺寸为 1.5 平方毫米，最大长度为 30 米。

使用电缆卷筒时，请务必拉出所有的电缆。

## 包装内的物品

包装内的物品包括：

- 1 台 部分组装的机器
- 1 个 纵切挡板
- 1 只 斜接计
- 1 个 上锯片防护罩组件
- 1 个 针板
- 2 只 锯片扳手
- 1 根 推杆
- 1 个 集尘适配器
- 1 本 说明手册

- 检查工具、部件或附件是否在运输过程中损坏。
- 操作前，请抽空仔细阅读并掌握本手册。

## 工具上的标记

工具上印有下列图形：



使用前请阅读使用手册。



请佩戴听力保护器。



请佩戴护目装备。



请佩戴呼吸防护装置。



双手要远离切割区域和锯片。



分料刀或分离器的厚度



锯片厚度和切口宽度



锯片直径



锯片防护罩释放杆



锁定/解锁主开关盖。



更换锯片之前先拔下锯的插头



保护电源线/插头不受潮且远离锯片的锋利边缘

## 日期码位置 (图 A)

日期码 **51** 印在工具外壳上，其中还包含制造年份。

示例:

2021 XX XX

制造年份

## 说明 (图 A、B)

**警告:** 切勿改装电动工具或其任何部件，否则可能会导致损坏或人身伤害。

- 1 锯台
- 2 锯片(中国和印度区域不包含锯片)
- 3 导轨刻度器
- 4 微调旋钮
- 5 导轨锁定杆
- 6 锯片高度调节轮
- 7 斜面锁定杆
- 8 开关
- 9 安装孔
- 10 斜接计
- 11 锯片防护罩组件
- 12 锯片防护罩释放杆
- 13 分离器
- 14 排尘口
- 15 防护罩排尘口
- 16 针板
- 17 纵切挡板
- 18 纵切挡板门锁
- 19 工件支撑/窄纵切挡板 (显示于存放位置)
- 20 锯片扳手
- 21 推杆 (显示于存放位置)
- 50 搬运手柄
- 52 非直通纵切分料刀 (显示于存放位置)

## 设计用途

DWE7492 台锯是专为木材，木材复合材料和塑料等各种材料进行专业的纵切、横切，斜切和倒角而设计的。

请勿在潮湿环境中或在易燃液体或气体存在的环境中使用本工具。

请勿用于切割金属，水泥板或砖石。

请勿在此锯上使用整形刀头。

请勿进行不带锥形夹具的锥形切割。

请勿使用锯进行切入或切槽。

本台锯为专业电动工具。

请勿让儿童接触工具。缺乏经验的操作员需要在监督下使用本工具。

- **儿童和体弱者。** 在没有他人监督的情况下，儿童或体弱者不适宜使用本产品。本产品不适合体力、感官或智力不足以及缺乏经验、知识或技能的人员(包括儿童)使用，除非一旁有能为他们的安全负责的监督人员。不得在无人监管的情况下让儿童接触本产品。

## 组装

**警告:** 为降低严重的人身伤害风险，在进行任何调整或取出/安装附件或配件之前，请关闭工具电源和断开工具电源连接。意外启动可能会导致人身伤害。

## 拆开包装

- 小心地拆除锯片的包装材料。
- 除纵切挡板、锯片防护罩组件、斜接计、锯片扳手和集尘减少器端口外，该机器已完全组装好。
- 按照下面所述的说明确定组装。

**警告:** 未使用推杆时，务必将其固定到位。

## 安装锯片 (图 A, C)

**警告:** 为降低人身伤害的风险，在拆、装配件或调整、更改工具之前，或在进行修理时，请关闭工具并拔下工具的电源插头。意外启动可能会导致人身伤害。

**警告:** 安装锯片时，请戴上防护手套。锯片的锯齿非常锋利，可能带来危险。

**警告:** 必须按照本部分中的说明更换锯片。只可按照技术参数中的说明使用锯片。

**警告:** 工作之后，请勿在冷却前触摸锯片。锯片在工作时会变得很热。

1. 顺时针旋转锯片高度调节轮 **6**，将锯片刀轴提升到最大高度。
2. 移除针板 **16**。参见 **安装针板**。
3. 用扳手 **20** 沿逆时针方向旋转，拧松并从轴上卸下螺母 **22** 和法兰 **24**。
4. 将锯片放在主轴上 **23**，确保锯齿 **2** 指向工作台的前面。将垫圈和刀杆螺母组装到主轴上，并用手将刀杆螺母 **22** 尽可能拧紧，确保锯片紧靠内部垫圈，而外法兰 **24** 紧靠锯片。确保法兰的最大直径紧靠锯片。确保主轴和垫圈无灰尘和碎屑。
5. 为了在拧紧刀杆螺母时防止主轴旋转，请使用锯片扳手 **20** 的开口端固定主轴。
6. 用扳手顺时针旋转拧紧螺母 **22**。
7. 放回针板。

**警告:** 更换锯片后，请始终检查纵切挡板指示器和锯片防护罩组件。

## 安装锯片防护罩组件/分料刀 (图 A, D)

**警告：**切割全程均需使用防护罩组件。

**警告：**当无法使用锯片防护罩组件时，请使用分料刀进行非直通切割。

**警告：**请勿将锯片防护罩组件和非直通切割分料刀同时插入夹具中。

**注：**锯出厂时已装有非直通式切割分料刀。

1. 将锯片刀轴提升到最大高度。
2. 拉动防护罩释放杆 **12** 并插入非直通式切割分料刀 **52** 或锯片防护罩组件 **11** 直至其触底，以安装锯片防护罩组件。
3. 释放杠杆，确保夹板完全合上，然后牢固固定分离器。

**警告：**在将台锯连接到电源或操作锯之前，请始终检查锯片防护罩组件是否正确对齐并与锯片保持适当间隙。每次改变斜角后都要检查对准情况。

**警告：**为减少严重人身伤害的危险，如果锯片组件未牢固地固定在适当的位置，请勿操作锯。

如果正确对准，分离器 **13** 或分料刀 **52** 将与锯台顶部的锯片持平，并且位于锯片顶部。使用直尺确保锯片 **2** 与分离器 **13** 或分料刀 **52** 对齐。在断开电源的情况下，在锯片的最大操作范围内调整其倾斜度和高度，并确保在所有操作中锯片防护罩组件均能对锯片起到保护作用。请参阅[将防护罩组件/分离器对准锯片](#)。

**警告：**正确安装并对齐锯片防护罩组件对安全操作至关重要！

## 移除锯片防护罩组件/分料刀 (图 D)

1. 拉动防护罩释放杆 **12**。
2. 提起锯片防护罩组件 **11** 或分料刀 **52**。

## 安装针板 (图 E)

1. 如图 E 所示对准针板 **16**，然后将针板背面的卡舌插入桌子开口背面的孔中。
2. 顺时针旋转锁定螺丝 **40** 90°，将工作台插件锁定到位。
3. 针板包括四个调节螺钉 **25**，用于升高或降低针板。正确调整后，针板的前部应齐平或略低于桌面表面，并固定到位。针板的后部应齐平或略高于桌面。

**警告：**切勿在没有针板的情况下使用机器。磨损或损坏时，请立即更换针板。

## 移除针板

1. 逆时针旋转锁定螺丝 **40** 90°，卸下针板 **16**。
2. 用指孔 **26** 向上和向前拉动针板以露出锯的内部。切勿在没有针板的情况下操作锯。如果使用开槽锯片，请使用合适的开槽针板 (另售)。

## 安装纵切挡板 (图 F)

纵切挡板可以安装在台锯右侧的两个位置上 (位置 1 进行 0 毫米至 62 厘米的纵切，位置 2 进行 20.3 厘米至 82.5 厘米的纵切) 和左侧的一个位置。

1. 解锁纵切挡板门锁 **18**。
2. 保持挡板成一定角度，将挡板导轨上的定位销 (前后) **29** 与挡板顶部插槽 **30** 对齐。
3. 将顶部插槽滑到销钉上，然后向下旋转挡板，直到其固定在导轨上。
4. 通过将前后门锁 **18** 合到导轨上，将挡板锁定在适当的位置。

## 台式安装 (图 A)

**注意：**为了减少人身伤害的危险，使用前请确保将台锯牢固地安装在稳定的表面上。

**警告：**确保表面足够稳定，以免大块材料在使用过程中翻倒。

台锯必须进行牢固安装。工具底座上有四个用于安装的孔 **9**。我们强烈建议使用这些孔将台锯固定到您的工作台或其他固定式刚性框架上。

1. 将锯放在一块 12.7 毫米的胶合板正中。
2. 用铅笔在锯的框架上标记两个后安装孔 (相距 220 毫米) 的位置。然后在两个相距 230 毫米的前孔前 498.5 毫米处进行测量。
3. 移开锯，在刚刚标记的地方钻 9 毫米的孔。
4. 将锯放在您在胶合板上钻的四个孔上，然后从底部插入四个 8 毫米的机器螺钉。在顶部安装垫圈和 8 毫米螺母。然后拧紧。
5. 为了防止螺钉头损坏夹锯的表面，请在胶合板底座的底部连接两条废木条。只要不从木条的底部伸出，就可以使用安装在顶部的木螺钉固定这些木条。
6. 每当使用锯时，请使用“C”形夹将胶合板底座固定到工作台上。

## 调整

### 锯片调节 (图 G)

#### 锯片对齐 (平行于斜切槽)

**警告：**切割危险。在 0° 和 45° 处检查锯片，以确保锯片没有撞到针板，从而造成人身伤害。

如果锯片似乎与桌面上的斜接器插槽未对准，则需要校准以进行对准。如需重新对齐锯片和斜接器插槽，请按照以下步骤进行：

**警告：**为降低人身伤害的风险，在拆、装配件或调整、修理工具之前，请关闭工具并拔出工具插头。意外启动可能会导致人身伤害。

1. 使用 5 毫米六角扳手松开位于桌子底侧的后枢轴支架紧固件 **32**，正好足以使支架左右移动。
2. 调节支架，直至锯片与斜接计插槽平行。
3. 将后枢轴支架紧固件拧紧至 12.5–13.6 Nm (110–120 英寸磅)。

#### 锯片高度调节 (图 A)

转动锯片高度调节轮 **6** 可以升高和降低锯片。

请确保锯切时，锯片的前三个锯齿刚刚穿透工件的上表面。这将确保在任何时间都使用最大锯齿数去除材料，从而提供最佳性能。

## 将防护罩部件/分离器对准锯片 (图 A, H)

1. 移除针板。请参阅[移除针板](#)。
2. 将锯片提升至最大切割深度和 0° 斜角。
3. 找到防护罩组件锁定轴 **38** 附近的三颗小紧定螺钉 **39**。这些螺钉将用于调节防护罩组件的位置。
4. 将直尺放在锯台并靠在两个锯片尖端上。分离器 **13** 不应接触直尺。如果需要，松开两个较大的锁定螺丝 **41**。
5. 调节小固定螺丝 **39**，以按照步骤 4 中所述的位置移动分离器。将直尺放在锯片的另一侧，并根据需要重复进行调整。
6. 轻轻松开两个较大的锁定螺丝 **41**。
7. 在分离器上放置一个正方形的平面，以验证分离器是否垂直且与锯片对齐。
8. 如果需要，请使用固定螺钉使分离器垂直于正方形。

- 重复步骤 4 和 5 以验证分离器的位置。
- 完全松开两个较大的锁定螺丝 **41**。
- 重新安装并锁定针板 **16**。

## 平行调整 (图 A, I, J, O)

**警告：**未对准的挡板 (未平行于锯片) 会增加反冲的危险!

为了获得最佳性能，锯片必须与纵切挡板平行。此调节操作在工厂完成。如需重新调节：

### 位置 1 挡板对齐

- 将挡板安装在位置 1 并解锁导轨锁定杆 **5**。找到支撑前导轨和后导轨上的挡板的两个定位销 **29**。
- 松开后定位器的定位螺钉，并调整挡板在凹槽中的对齐方式，直到挡板面与锯片平行。确保从挡板面到锯片的正面和背面进行测量以确保对齐。
- 拧紧定位器螺丝，然后在锯片的左侧重复上述步骤。
- 检查纵切刻度指针的调整 (图 J)。

### 位置 2 挡板对齐

- 要对齐位置 2 的挡板定位器销钉 **29**，请确保位置 1 的销钉已对齐，请参阅 **位置 1 挡板对齐方式**。
- 松开位置 2 的销钉，然后使用锯片扳手孔作为定位指导，对准销钉 (图 O)。
- 拧紧定位销 (前后)。

## 调节导轨刻度 (图 A, J)

- 解锁导轨锁定杆 **5**。
- 将锯片设置为 0° 斜角，然后将挡板移入直到碰到锯片。
- 锁定导轨锁定杆。
- 松开导轨刻度指示器螺丝 **31**，并将导轨刻度指示器设置为零 (0)。重新拧紧导轨刻度器螺丝。仅当挡板安装在锯片的右侧并且位于位置 1 (对于 0 到 62 厘米的纵切) 而不是 82.5 厘米的纵切位置时，黄色导轨刻度器 (顶部) 才能正确读取。仅当将挡板安装在锯片的右侧并位于位置 2 时 (对于 20.3 厘米至 82.5 厘米的纵切)，白色导轨刻度器 (底部) 才能正确读取。

只有将挡板安装在锯片右侧时，导轨刻度读数才正确。

## 导轨锁定调节 (图 A, K)

导轨锁定已经过出厂设置。如果您需要重新调节，请按以下步骤操作：

- 锁定导轨锁定杆 **5**。
- 在锯的下面，松开防松螺母 **33**。
- 拧紧六角杆 **34**，直至锁定系统上的簧压压缩并在导轨锁定杆上产生所需的张力。重新将安全螺母拧在六角杆上。
- 将锯翻转过来，并检查在锁定杆接合时挡板没有移动。如果挡板仍然松动，请进一步拧紧弹簧。

## 斜面止动和指针调节 (图 L)

- 顺时针旋转锯片高度调节轮 **6** 直至其停止完全抬起锯片。
- 将斜面锁定杆 **7** 向上方和右侧推动来将其解锁。旋松斜面止动螺丝 **36**。
- 在桌面和锯齿之间的锯片上放置一个正方形的平面。确保斜角锁定杆处于解锁或向上位置。
- 使用斜面锁定杆调整斜角角度，直到锯片对着正方形平放为止。

- 向下推紧斜面锁定杆。
- 转动斜面止动凸轮 **35**，直至它紧靠轴承块。旋紧斜面止动螺丝 **36**。
- 查看斜角刻度。如果指针读数不为 0°，请松开指针螺丝 **37** 并移动指针以使其读数正确。紧固指针螺丝。
- 在 45° 重复这一步骤，但不要调整指针。

## 斜接计调节 (图 A)

如需调节斜接计 **10**，松开旋钮，将其设置为所需角度并拧紧旋钮。

## 身体和手的位置

在操作台锯时，如果身体与手放置在正确的位置，则可以更轻松、更准确的进行切割。

- 警告：**
- 双手切勿靠近切割区域。
  - 双手距离锯片的距离不小于 150 毫米。
  - 请勿交叉双手。
  - 请将双脚稳固于地面，并保持身体平衡。

## 使用前的准备工作

- 警告：**
- 安装合适的锯片。请勿使用过度磨损的锯片。工具的最大转速严禁超过锯片的最大速度。
  - 请勿尝试切割过小的工件。
  - 让锯片自由切割。请勿用力过猛。
  - 切割前让电机达到全速。

## 操作

### 使用说明

- 警告：**务必遵守安全指示和适用法规。
- 警告：**为降低严重的人身伤害风险，在进行任何调整或取出/安装附件或配件之前，请关闭工具电源和断开工具电源连接。意外启动可能会导致人身伤害。

请确保锯片位置在锯台高度及稳定度方面符合您的人机工程学情况。操作时应为操作员选择一个拥有良好视野及充分自由活动空间的场所，以便操作员在没有限制的情况下处理工件。

为降低振动增加的影响，请防止环境温度过低、确保机器与配件维护良好、且工件大小与本机相匹配。

- 警告：**
- 请确保锯片位置在锯台高度及稳定度方面符合您的人机工程学情况。操作时应为操作员选择一个拥有良好视野及充分自由活动空间的场所，以便操作员在没有限制的情况下处理工件。
  - 安装合适的锯片。请勿使用过度磨损的锯片。工具的最大转速严禁超过锯片的最大速度。
  - 请勿尝试切割过小的工件。
  - 让锯片自由切割。请勿用力过猛。
  - 切割前让电机达到全速。
  - 确保所有锁定旋钮和夹具手柄紧固。
  - 在工具已连接到电源的情况下，禁止将手放置于锯片区。

- 切勿使用电锯进行徒手切割！
- 切勿锯切扭曲、弯折或杯形的工件。必须有至少一个顺滑的直边来放置纵切挡板或斜接导尺。
- 始终为较长的工件提供支架以防止回弹。
- 请勿在锯片运转时去除锯片区域的任何锯屑物。

## 启动与关闭 (图 M)

锯台的开/关 **8** 具有多种优点：

- 无电压释放功能：如果出于任何原因切断电源，则必须刻意重新启动开关。
- 要启动机器，请按下绿色的启动按钮。
- 要关闭机器，请按下红色的停止按钮。

### 锁定功能说明

开关上方的盖子可向下折叠以插入挂锁以锁定锯。建议使用最大直径为 6.35 毫米，最小间隙为 76.2 毫米的挂锁。

## 纵切挡板操作 (图 N-P)

### 导轨锁定杆

导轨锁定杆 **5** 将挡板锁定在适当的位置，以防止切割过程中移动。如需锁定导轨杆，请向下推并向锯的后部推。如需解锁，请将其向上拉动并朝锯的前面拉动。

**注：**切割时，请始终锁定导轨锁定杆。

### 工件支架扩展/窄纵向挡板

您的台锯配有工件支架扩展，以支持超出锯台尺寸的工件。

如需在工件支架位置使用窄纵向挡板，请如图 O 所示将其从存放位置旋转，然后将销钉滑入挡板两端的下部插槽 **27** 中。

要在窄纵切位置使用窄纵切挡板，请将销钉卡入挡板两端的上部插槽 **28** 中。此功能将为锯片留出 51 毫米的额外间隙。参见图 P。

**注：**在台锯上进行工作时，缩回工件支架延伸件或将其调整至窄纵切挡板位置。

**注：**使用窄纵切挡板时，请从所示的导轨刻度读数中减去 51 毫米。

### 微调旋钮

设置挡板时，微调旋钮 **4** 允许进行较小的调整。调整之前，请确保导轨锁定杆处于向上或解锁位置。

### 导轨刻度指示器

如果用户在粗和细的锯齿锯片之间进行切换，则需要调整导轨刻度指示器，以使纵切挡板发挥适当的性能。仅当将挡板安装在锯片右侧的位置 1 或 2 时，导轨刻度指示器才能正确读取。当使用窄纵切挡板进行窄纵切（不在工件支架位置）时，请从所示的导轨刻度读数中减去 51 毫米。请参阅 **调整下的调节导轨刻度**。

## 基本锯切

### 直切操作



**警告：**所有直切操作全程均需使用锯片防护罩组件。

### 纵向切割 (图 A, B, Q, R)



**警告：**锋利的边缘。

1. 将锯片设置为 0°。
2. 安装纵切挡板并锁定挡板门锁 **18** (图 A)。
3. 抬起锯片，直到其比工件顶部高 3 毫米。必要时调节上锯片防护罩的高度。

4. 调整挡板的位置并锁定导轨锁定杆 **5**，请参阅 **纵切挡板操作**。
5. 将工件在锯台上按平并靠着导尺。保持工件远离锯片。
6. 保持双手远离锯片路径 (图 Q)。
7. 开启机器并允许锯片达到全速。
8. 缓缓将工件送入防护罩下方，将其紧紧压住纵切挡板。允许锯齿切割，但不强制工件穿过锯片。锯片的速度应该保持稳定。
9. 在靠近锯片的位置工作时，请始终使用推杆 **21** (图 R)。
10. 完成切割后，关闭机器，使锯片停止并移除工件。



**警告：**

- 切勿推动或握住工件的“无保护”或切割端。
- 请勿切割过小的工件。
- 纵向切割较小的工件时，始终使用推杆。

## 斜面切割 (图 A)

1. 如需设置所需的斜角，请向上推并向右旋转斜角锁定杆 **7**。
2. 如需将其设置为所需角度，请向下并向左推动控制杆以将其锁定到位。
3. 按照纵向切割的操作继续。

## 横切和斜角横切 (图 Q)

1. 移除纵切挡板并将斜接计安装在所需的插槽中。
2. 将斜接计锁定在 0°。
3. 按照纵向切割的操作继续。

## 斜接切割 (图 A)

1. 将斜接计 **10** 设置为所需角度。

**注：**始终将工件紧紧靠在斜接计的表面上。

2. 按照纵向切割的操作继续。

## 双向斜面

此切割是斜接切与斜面切的组合。将斜面设置为所需的角度的，并按照斜接横切的操作继续。

## 长材料的支撑

- 请务必为长材料提供支撑。
- 请使用任何方便的方法（比如锯木架或类似设备）支架长工件，以防止其两端掉落。

## 非直切 (开槽和打钉)



**警告：**卸下锯片防护罩组件 **11** 并安装非直切式分流刀 **52** 以进行非直切式切割操作。在不能使用锯片防护罩组件，防反冲组件和分料刀的所有非直切操作中，请使用羽毛板。

**纵切、横切、斜角横切、斜切和复合磨削**部分中的说明适用于贯穿材料整个厚度的切割。该锯还可以执行非直切式操作，以在材料中形成凹槽或槽口。

### 非直切式纵切 (图 D, U)



**警告：**应始终使用纵切挡板进行纵切操作，以防止失控和人身伤害。切勿徒手执行纵向切割操作。始终将挡板锁定在导轨上。



**警告：**在进行斜面纵切时，只要有可能，请将防护罩放在锯片的侧面，以使锯片远离挡板和双手。

**警告：**保持双手远离锯片。使用非直切式切割时，锯片在切割过程中并非始终可见，因此必须格外小心，以确保双手远离锯片。

**警告：**如果挡板和锯片之间的距离为 51–152 毫米，请使用推杆进给工件。如果挡板和锯片之间的距离小于或等于 51 毫米，请使用窄纵切挡板功能并用推块进给工件。

- 卸下锯片防护罩组件 **11** 并安装非直切式分流刀 **52** (图 D)。请参见：**安装锯片防护罩组件/分流刀**。
- 向下按导轨锁定杆，锁定纵切挡板。移除斜接计。
- 将锯片提升到所需的切割深度。
- 将工件在锯台上按平并靠着导尺。保持工件远离锯片约 25.4 毫米。

**警告：**工件必须与档板呈直角，并且不得翘曲，扭曲或弯曲。保持双手远离锯片和锯片路径。如图 U 所示参见正确的手部位置。

- 打开锯，让锯片加速。可以使用双手开始进行切割。当工件还剩下大约 305 毫米时，请只用一只手的拇指进给材料，用食指将材料压住，其他手指钩在挡板上。始终将拇指保持在前两个手指旁边并靠近挡板。
- 将工件保持在工作台和档板上，将其缓慢地一直向后穿过锯片。继续推动工件，直到其脱离锯片防护罩组件并且从工作台后部掉落。请勿使电动机过载。
- 切勿在锯片转动时将工件拉回。关闭开关，让锯片停下来并将工件滑出。
- 锯切较长的材料或面板时，请始终使用工件支架。锯木架，滚筒或进出组件为此目的提供了足够的支撑。工作支架必须与锯台处于同一高度或略低于锯台。

## 非直切小块工件 (图 A)

纵切小块工件是不安全的。将手靠近锯片是不安全的。相反，应纵切较大的工件以获得所需的工件尺寸。当要纵切一小段宽度并且无法安全地将手放在锯片和纵切挡板之间时，请使用一个或多个推杆。该锯附带一个推杆 **21**，该推杆安装在纵切挡板上。用推杆将工件固定在工作台和挡板上，然后将工件完全推过锯片。

## 非直切式斜角纵切 (图 V)

除了将斜角设置为零度以外的角度，此操作与非直切式切割相同。如何正确放置双手，请参考图 V。

**警告：**在连接到电源或操作锯之前，请始终检查分料刀是否正确对齐并与锯片保持适当间隙。每次改变斜角后都要检查对准情况。

## 非直切式横切 (图 W)

**警告：**切勿将纵切挡板与斜接计同时使用。

**警告：**为减少受伤的危险，切勿在横切时使用挡板作为导向或限位器。

**警告：**当使用一块木块作为截止量规时，该木块必须至少为 19 毫米厚，这对放置木块的后端非常重要，以使工件在进入锯片之前先离开木块以防止与锯片接触，因为锯片会导致工件抛出并可能造成伤害。

- 移除纵切挡板并将斜接计放置在所需的插槽中。
- 将锯片高度调整到所需的切割深度。
- 将锯片牢固地靠在斜接计 **10** 上，并使锯片的路径与所需的切割位置保持一致。将工件保持在锯片前一英寸左右。保持双手远离锯片和锯片路径 (图 W)。

- 打开锯电动机，让锯片加速。

- 用双手将工件保持在斜接计的表面上，同时将工件平放在工作台上，缓慢地将工件推过锯片。

- 切勿在锯片转动时将工件拉回。关闭开关，让锯片停下来并小心地将工件滑出。

## 非直切式斜切

除了将斜角设置为零度以外的角度，此操作与横切相同。

**警告：**在连接到电源或操作锯之前，请始终检查分料刀是否正确对齐并与锯片保持适当间隙。每次改变斜角后都要检查对准情况。

## 非直切式斜切 (图 W)

除了将斜接计锁定在零度以外的角度，此操作与横切相同。将工件牢牢地靠在斜接计 **10** 上，然后将工件缓慢送入锯片中 (以防止工件移动)。

## 非直切式斜接计操作

按照以下步骤设置您的斜接计：

- 松开斜接计锁旋钮 **46**。
- 将斜接计移动到所需角度。
- 锁定斜接计锁定旋钮。

## 非直切式复合斜切

这是非直切式斜切和非直切式斜接的组合。请按照非直切式斜切和非直切式斜接的组合说明进行操作。



## 集尘 (图 A, AA)

本机在背面提供了排尘口 **14**，适用于配备 57/65 毫米喷嘴的排尘设备。机器随附一个变径接头口，适用于直径为 34-40 毫米的排尘喷嘴。

机器随附的减速器端口用于 DEWALT AirLock 系统 (DWV9000-XJ)。锯片防护罩组件还具有用于 35 毫米喷嘴的排尘口，或直接连接到 DEWALT AirLock (DWV9000-XJ)。

来自诸如含铅涂层和某些木材类型材料的粉尘可能会危害人体健康。吸入这些粉尘会引起过敏反应和/或导致使用者或旁观者呼吸道感染。

某些灰尘，如橡木或山毛榉灰尘，被认为是致癌物质，尤其是与木材处理添加剂有关。

遵守您所在国家/地区有关所用材料的相关规定。

真空吸尘器必须适合所吸取的材料。

在清除对健康有害或可致癌的干粉尘时，请使用 M 级吸尘器。

锯片防护罩组件还具有用于 35 毫米喷嘴 (M 级吸尘器) 的排尘口。

- 在所有操作中，请连接按照与排尘相关的法规设计的排尘设备。
- 确保使用的排尘软管适合应用和要切割的材料。确保对软管进行正确维护。
- 请注意，硬纸板或中密度纤维板等人工材料在切割时会产生比天然木材更多的灰尘颗粒。

## 存放 (图 B, X-Z)

不使用时，请以安全的方式存放机器。存放地点必须保持干燥且可上锁。这样可以防止机器损坏存储空间以及防止未经培训的人员操作机器。

1. 将推杆 **21** 固定在挡板上。
2. 移除锯片防护罩组件。请参见 **移除锯片防护罩组件**。如图所示将锯片防护罩组件 **11** 滑入支架，然后旋转锁定旋钮 1/4 以将其锁定到位。参见图 X。
3. 将锯片扳手 **20** 滑入袋中，直到黄色按钮与孔对齐以固定到位，请参见图 B。
4. 将斜设计的导杆插入袋中，直到触底。
5. 在此位置缠绕电线 **43**。参见图 Z。
6. 如需存放挡板，请将工件支架置于存储位置。从导轨上卸下挡板。重新将挡板上颠倒地安装在锯的左侧，请参见图 Y。请勿将定位器插槽钩在左侧挡板定位器螺钉上。如图所示，这些螺钉将与挡板上的空隙对准。合上纵切挡板门锁 **18** 以固定。
7. 可以将非直切式分料刀 **52** 安装在锯中（工作位置）或与锯片防护罩组件一起存放。参见图 B。

## 搬运 (图 A, B)

在运输之前，必须完成以下步骤：

- 将电线缠绕好
- 沿逆时针方向旋转锯片高度调节轮 **6**，直到锯片的齿位于锯台下方。锁定斜面锁定杆 **7**。
- 将挡板导轨完全向内滑动并通过导轨锁定杆将其固定 **5**。
- 请始终使用指定的手柄 **50** 搬运机器，请参阅图 A 和 B。



**警告：**始终在安装好上锯片防护罩的情况下搬运机器。

## 维护

DEWALT 电动工具设计精良，可以长时间使用，而且只需极少的维护。要持续获得令人满意的工作效果，需要进行合适的工具维护和定期清洁。



**警告：**为降低严重的人身伤害风险，在进行任何调整或移除/安装配件或附件之前，请关闭工具电源和断开工具电源连接。意外启动可能会导致人身伤害。



## 润滑 (图 T)

电机和轴承不需要另外润滑。如果升降锯片变得困难，请清洁并润滑高度调节螺丝：

1. 将锯从电源上断开。
2. 将电锯转向一边。
3. 如图 T 所示，清洁并润滑该锯底部的高度调节螺钉螺纹 **42**。使用通用油脂。



## 清洁 (图 A, S)



**警告：**为了降低严重人身伤害风险，请在清洁前先关闭装置并断开机器的电源连接。意外启动可能会导致人身伤害。



**警告：**一旦看到通风口及其周围积聚了尘屑，请用干燥的空气将灰尘和尘屑从主机外壳内吹出。执行此过程时，需戴上经认可的护目装备和防尘面具。



**警告：**切勿使用溶剂或其他刺激性化学制品来清洁工具的非金属部件。这些化学物质可能会削弱这些部位使用的材料。请用布蘸温和的肥皂水擦拭。切勿让任何液体渗入工具，切勿让工具的任何部件浸在液体中。



**警告：**为降低受伤风险，请定期清洁锯台顶部。



**警告：**为降低受伤风险，请定期清洁集尘系统。

在操作锯之前，必须将锯片防护罩组件 **11** 和针板放置到位。在使用前，请仔细检查上下锯片防护罩和防尘管，以确定其可正常工作。确定碎屑、尘屑或工件微粒不会阻碍其中任一功能。为防止锯片与防护罩间被工件碎片堵塞，请断开机器电源，并按照**安装锯片**中的指示进行操作。拆下堵塞的部件并重新组装锯片。保持通风槽无阻塞并定期使用软布清洁外壳。

定期清洁集尘系统：

1. 拔掉斜切锯插头。
2. 将锯旋转至侧面，以便可以接近装置的底部开口部分。
3. 打开如图 S 所示的灰尘通道门 **44**，松开两个螺钉，然后将两个侧夹 **45** 彼此相对按下。清除多余的灰尘，然后将侧夹完全推入到位，然后拧紧锁紧螺丝以重新固定。

## 可选配件



**警告：**除了 DEWALT 提供的附件之外，其他附件都未经此产品兼容性测试，若将此类附件与本工具一起使用将存在安全隐患。为降低人身伤害风险，本产品只可使用 DEWALT 推荐的附件。

请向您的经销商咨询更多关于合适附件的信息。

磨损时请更换锯片防护罩。请与您当地的 DEWALT 服务中心联系，以获取有关锯片防护罩更换的详细信息。

**锯片：**请务必使用带 25.4 毫米轴孔的 254 毫米降噪锯片。锯片速度额定值必须至少达到 5000 RPM。切勿使用小于上述直径的锯片。否则无法对您进行妥善保护。

锯片说明		
应用	直径	锯齿
<b>建筑用锯片 (快速纵切)</b>		
通用	254 毫米	24
精细横切	254 毫米	40
<b>木工用锯片 (提供平滑、干净的切割)</b>		
精细横切	254 毫米	60

请向您的经销商咨询更多关于合适附件的信息。

- DWE74911 旋转台锯支架
- DWE74912 剪刀脚支架

## 保护环境



分类回收。由此符号标记的产品和电池不得与普通家庭垃圾一起处理。

产品和电池包含可恢复或回收的材料，从而降低对原材料的需求。请根据当地供给回收电子产品和电池。要获得更多信息，请参看 [www.2helpU.com](http://www.2helpU.com)。

制造商：百得德国公司

地址：Black & Decker Str.40 65510 Idstein, 德国

产地：江苏苏州



## 产品中有害物质的名称及含量

部件名称 Parts name	有害物质					
	铅 (Pb)	汞 (Hg)	镉 (Cd)	六价铬 (Cr(VI))	多溴联苯 (PBB)	多溴二苯醚 (PBDE)
马达组件	O	O	O	O	O	O
机壳组件	O	O	O	O	O	O
控制部件 (开关, PCB 等)	X	O	O	O	O	O
传动部件	X	O	O	O	O	O
电线组件	X	O	O	O	O	O
附件(钻头/砂轮片等)	O	O	O	O	O	O

本表格依据 SJ/T 11364 的规定编制。

O: 标识该有害物质在该部位所有均质材料中的含量均在 GB/T 26572 规定的限量要求以下。

X: 标识该有害物质至少在该部位的某一均质材料中的含量超出 GB/T 26572 规定的限量要求。

备注: 本产品不必包含以上所述的所有部件。由于生产工艺和技术的不可替代性, 本产品中含有某些有害物质, 在环保使用期限内可以放心使用, 超过环保使用期限之后则应进入回收循环系统。

环保使用期限为“电子电气产品中含有的有害物质不会发生外泄或突变, 电子电气产品用户正常使用该电子电气产品不会对环境造成严重污染或对其人身、财产造成严重损害的期限”。



: 环保使用期限为 20 年。此环保使用期限不代表产品的安全使用期限和质量保证年限。





