

---

# **DEWALT®**

---

**DWE8202T**  
**DWE8202S**  
**DWE8212S**

**[www.DEWALT.com](http://www.DEWALT.com)**

---

**English (*original instructions*)**

---

**03**

**简体中文**

---

**14**

Figure 1

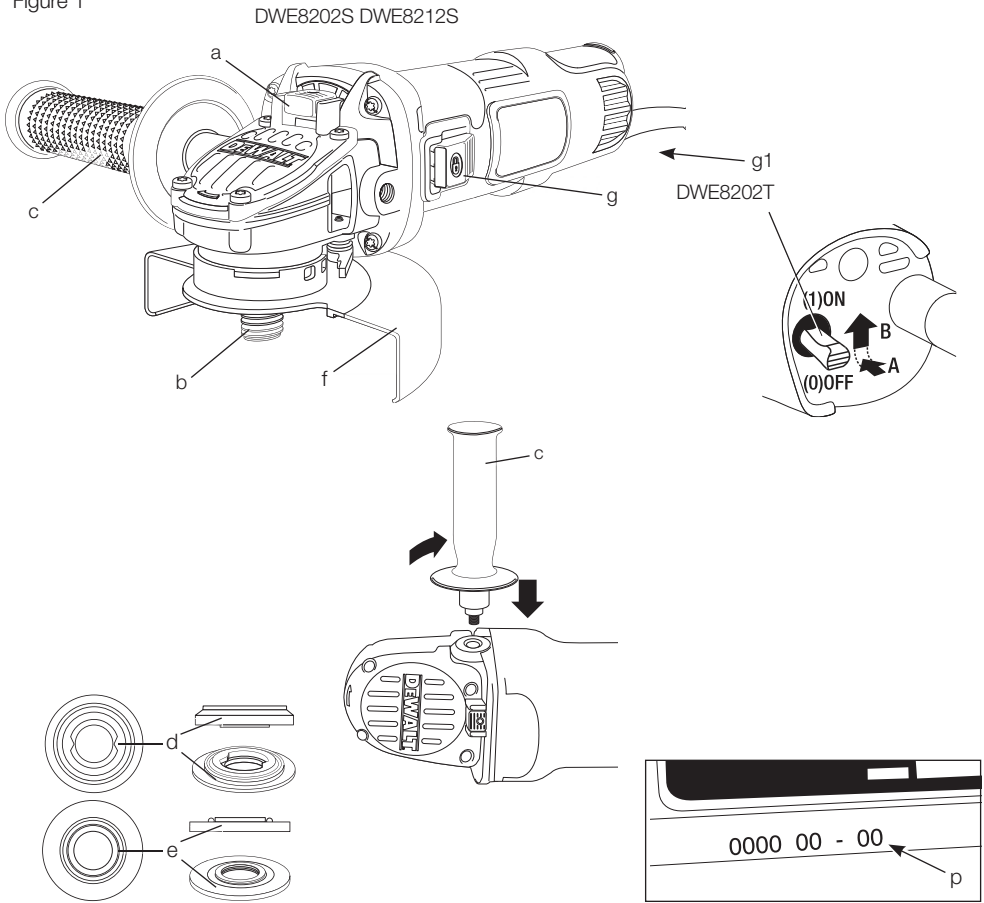

Figure 2

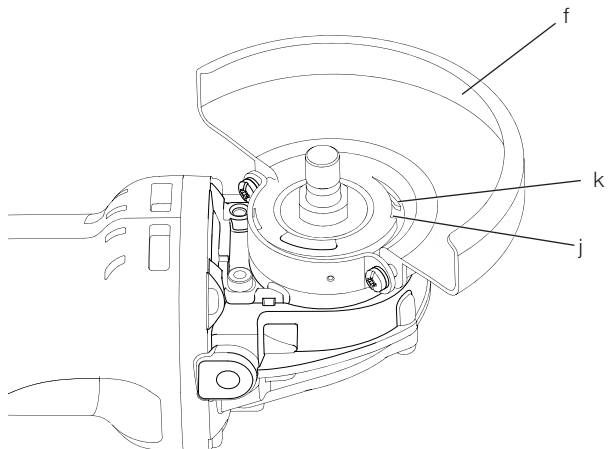

Figure 3

DWE8202S DWE8212S

DWE8202T

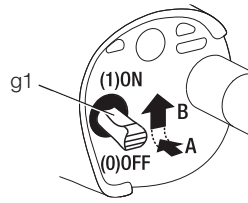
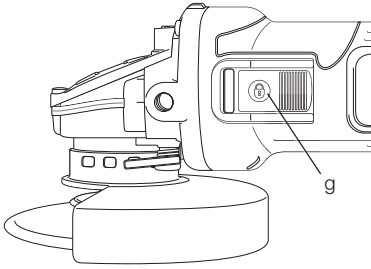

Figure 4

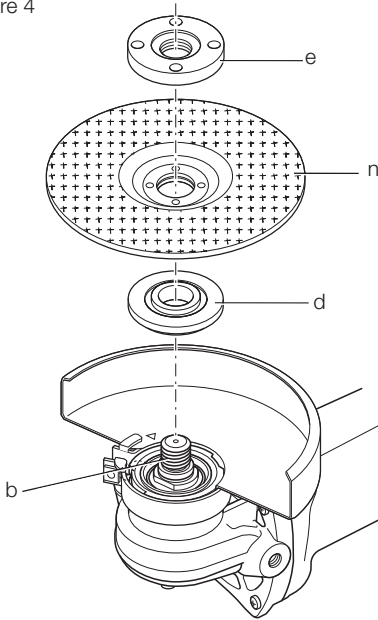

Figure 5

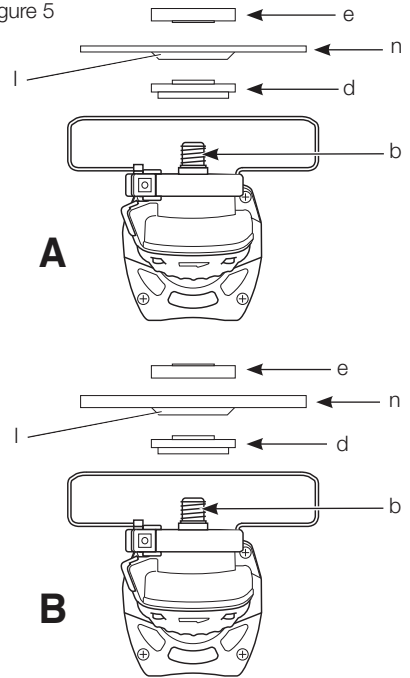
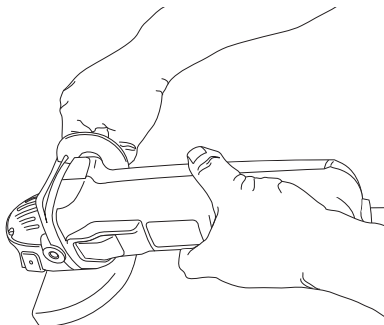

Figure 6



# ANGLE GRINDERS

## DWE8202T, DWE8202S, DWE8212S

### Congratulations!

You have chosen a DEWALT tool. Years of experience, thorough product development and innovation make DEWALT one of the most reliable partners for professional power tool users.

### Technical Data

		DWE8202T	DWE8202S	DWE8212S
Voltage	V	220-240	220-240	220-240
Type		1	1	1
Power input	W	890	890	890
No-load/rated speed	/min	12000	12000	12000
Wheel diameter	mm	100	100	125
Spindle diameter		M10	M10	M14
Switch style		toggle	slide	slide
Weight	kg	1.75*	1.75*	1.95*

\* weight without side handle, cordset and wire; with guard and flanges.

### Definitions: Safety Guidelines

The definitions below describe the level of severity for each signal word. Please read the manual and pay attention to these symbols.



**DANGER:** Indicates an imminently hazardous situation which, if not avoided, **will result in death or serious injury.**



**WARNING:** Indicates a potentially hazardous situation which, if not avoided, **could result in death or serious injury.**



**CAUTION:** Indicates a potentially hazardous situation which, if not avoided, **may result in minor or moderate injury.**

**NOTICE:** Indicates a practice **not related to personal injury** which, if not avoided, **may result in property damage.**



Denotes risk of electric shock.



Denotes risk of fire.



**WARNING:** To reduce the risk of injury, read the instruction manual.

### General Power Tool Safety Warnings



**WARNING! Read all safety warnings and all instructions.** Failure to follow the warnings and instructions may result in electric shock, fire and/or serious injury.

#### SAVE ALL WARNINGS AND INSTRUCTIONS FOR FUTURE REFERENCE

The term "power tool" in the warnings refers to your mains-operated (corded) power tool or battery-operated (cordless) power tool.

#### 1) WORK AREA SAFETY

- Keep work area clean and well lit.** Cluttered or dark areas invite accidents.
- Do not operate power tools in explosive atmospheres, such as in the presence of flammable liquids, gases or dust.** Power tools create sparks which may ignite the dust or fumes.
- Keep children and bystanders away while operating a power tool.** Distractions can cause you to lose control.

#### 2) ELECTRICAL SAFETY

- Power tool plugs must match the outlet. Never modify the plug in any way. Do not use any adapter plugs with earthed (grounded) power tools.** Unmodified plugs and matching outlets will reduce risk of electric shock.

- b) **Avoid body contact with earthed or grounded surfaces such as pipes, radiators, ranges and refrigerators.** There is an increased risk of electric shock if your body is earthed or grounded.
- c) **Do not expose power tools to rain or wet conditions.** Water entering a power tool will increase the risk of electric shock.
- d) **Do not abuse the cord. Never use the cord for carrying, pulling or unplugging the power tool. Keep cord away from heat, oil, sharp edges or moving parts.** Damaged or entangled cords increase the risk of electric shock.
- e) **When operating a power tool outdoors, use an extension cord suitable for outdoor use.** Use of a cord suitable for outdoor use reduces the risk of electric shock.
- f) **If operating a power tool in a damp location is unavoidable, use a residual current device (RCD) protected supply.** Use of an RCD reduces the risk of electric shock.

### 3) PERSONAL SAFETY

- a) **Stay alert, watch what you are doing and use common sense when operating a power tool. Do not use a power tool while you are tired or under the influence of drugs, alcohol or medication.** A moment of inattention while operating power tools may result in serious personal injury.
- b) **Use personal protective equipment. Always wear eye protection.** Protective equipment such as dust mask, non-skid safety shoes, hard hat, or hearing protection used for appropriate conditions will reduce personal injuries.
- c) **Prevent unintentional starting. Ensure the switch is in the off position before connecting to power source and/or battery pack, picking up or carrying the tool.** Carrying power tools with your finger on the switch or energising power tools that have the switch on invites accidents.
- d) **Remove any adjusting key or wrench before turning the power tool on.** A wrench or a key left attached to a rotating part of the power tool may result in personal injury.
- e) **Do not overreach. Keep proper footing and balance at all times.** This enables better control of the power tool in unexpected situations.
- f) **Dress properly. Do not wear loose clothing or jewellery. Keep your hair,**

**clothing and gloves away from moving parts.** Loose clothes, jewellery or long hair can be caught in moving parts.

- g) **If devices are provided for the connection of dust extraction and collection facilities, ensure these are connected and properly used.** Use of dust collection can reduce dust-related hazards.

### 4) POWER TOOL USE AND CARE

- a) **Do not force the power tool. Use the correct power tool for your application.** The correct power tool will do the job better and safer at the rate for which it was designed.
- b) **Do not use the power tool if the switch does not turn it on and off.** Any power tool that cannot be controlled with the switch is dangerous and must be repaired.
- c) **Disconnect the plug from the power source and/or the battery pack from the power tool before making any adjustments, changing accessories, or storing power tools.** Such preventive safety measures reduce the risk of starting the power tool accidentally.
- d) **Store idle power tools out of the reach of children and do not allow persons unfamiliar with the power tool or these instructions to operate the power tool.** Power tools are dangerous in the hands of untrained users.
- e) **Maintain power tools. Check for misalignment or binding of moving parts, breakage of parts and any other condition that may affect the power tool's operation. If damaged, have the power tool repaired before use.** Many accidents are caused by poorly maintained power tools.
- f) **Keep cutting tools sharp and clean.** Properly maintained cutting tools with sharp cutting edges are less likely to bind and are easier to control.
- g) **Use the power tool, accessories and tool bits etc., in accordance with these instructions taking into account the working conditions and the work to be performed.** Use of the power tool for operations different from those intended could result in a hazardous situation.

### 5) SERVICE

- a) **Have your power tool serviced by a qualified repair person using only identical replacement parts.** This will ensure that the safety of the power tool is maintained.

## ADDITIONAL SPECIFIC SAFETY RULES

### Safety Instructions for All Operations

- a) **This power tool is intended to function as a grinder, sander, wire brush, polisher or cut-off tool. Read all safety warnings, instructions, illustrations and specifications provided with this power tool.** Failure to follow all instructions listed below may result in electric shock, fire and/or serious injury.
- b) **Do not use accessories which are not specifically designed and recommended by the tool manufacturer.** Just because the accessory can be attached to your power tool, it does not assure safe operation.
- c) **The rated speed of the accessory must be at least equal to the maximum speed marked on the power tool.** Accessories running faster than their rated speed can break and fly apart.
- d) **The outside diameter and the thickness of your accessory must be within the capacity rating of your power tool.** Incorrectly sized accessories cannot be adequately guarded or controlled.
- e) **The arbour size of wheels, flanges, backing pads or any other accessory must properly fit the spindle of the power tool.** Accessories with arbour holes that do not match the mounting hardware of the power tool will run out of balance, vibrate excessively and may cause loss of control.
- f) **Do not use a damaged accessory. Before each use inspect the accessory such as abrasive wheel for chips and cracks, backing pad for cracks, tear or excess wear, wire brush for loose or cracked wires. If power tool or accessory is dropped, inspect for damage or install an undamaged accessory. After inspecting and installing an accessory, position yourself and bystanders away from the plane of the rotating accessory and run the power tool at maximum no-load speed for one minute.** Damaged accessories will normally break apart during this test time.
- g) **Wear personal protective equipment. Depending on application, use face shield, safety goggles or safety glasses. As appropriate, wear dust mask, hearing protectors, gloves and workshop apron capable of stopping small abrasive or workpiece fragments.** The eye protection must be capable of stopping flying debris generated by various operations. The dust mask or respirator must be capable of filtering particles generated by your operation. Prolonged exposure to high intensity noise may cause hearing loss.
- h) **Keep bystanders a safe distance away from work area. Anyone entering the work area must wear personal protective equipment.** Fragments of workpiece or of a broken accessory may fly away and cause injury beyond immediate area of operation.
- i) **Hold power tool by insulated gripping surfaces only, when performing an operation where the cutting accessory may contact hidden wiring or its own cord.** Cutting accessory contacting a "live" wire may make exposed metal parts of the power tool "live" and could give the operator an electrical shock.
- j) **Position the cord clear of the spinning accessory.** If you lose control, the cord may be cut or snagged and your hand or arm may be pulled into the spinning accessory.
- k) **Never lay the power tool down until the accessory has come to a complete stop.** The spinning accessory may grab the surface and pull the power tool out of your control.
- l) **Do not run the power tool while carrying it at your side.** Accidental contact with the spinning accessory could snag your clothing, pulling the accessory into your body.
- m) **Regularly clean the power tool's air vents.** The motor's fan will draw the dust inside the housing and excessive accumulation of powdered metal may cause electrical hazards.
- n) **Do not operate the power tool near flammable materials.** Sparks could ignite these materials.
- o) **Do not use accessories that require liquid coolants.** Using water or other liquid coolants may result in electrocution or shock.

## FURTHER SAFETY INSTRUCTIONS FOR ALL OPERATIONS

### Causes and Operator Prevention of Kickback

Kickback is a sudden reaction to a pinched or snagged rotating wheel, backing pad, brush or any other accessory. Pinching or snagging causes rapid stalling of the rotating accessory which in turn causes the uncontrolled power tool to be forced in the direction opposite of the accessory's rotation at the point of the binding.

For example, if an abrasive wheel is snagged or pinched by the workpiece, the edge of the wheel that is entering into the pinch point can dig into the surface of the material causing the wheel to climb out or kick out. The wheel may either jump toward or away from the operator, depending on direction of the wheel's movement at the point of pinching. Abrasive wheels may also break under these conditions.

Kickback is the result of tool misuse and/or incorrect operating procedures or conditions and can be avoided by taking proper precautions as given below:

- a) **Maintain a firm grip on the power tool and position your body and arm to allow you to resist kickback forces. Always use auxiliary handle, if provided, for maximum control over kickback or torque reaction during start up.** The operator can control torque reaction or kickback forces, if proper precautions are taken.
- b) **Never place your hand near the rotating accessory.** Accessory may kickback over your hand.
- c) **Do not position your body in the area where power tool will move if kickback occurs.** Kickback will propel the tool in direction opposite to the wheel's movement at the point of snagging.
- d) **Use special care when working corners, sharp edges etc. Avoid bouncing and snagging the accessory.** Corners, sharp edges or bouncing have a tendency to snag the rotating accessory and cause loss of control or kickback.
- e) **Do not attach a saw chain woodcarving blade or toothed saw blade.** Such blades create frequent kickback and loss of control.

## Safety Warnings Specific for Grinding and Abrasive Cutting-Off Operations

- a) **Use only wheel types that are recommended for your power tool and the specific guard designed for the selected wheel.** Wheels for which the power tool was not designed cannot be adequately guarded and are unsafe.
- b) **The guard must be securely attached to the power tool and positioned for maximum safety, so the least amount of wheel is exposed towards the operator.** The guard helps to protect operator from broken wheel fragments and accidental contact with wheel.
- c) **Wheels must be used only for recommended**

**applications. For example: do not grind with the side of cut-off wheel.** Abrasive cut-off wheels are intended for peripheral grinding, side forces applied to these wheels may cause them to shatter.

- d) **Always use undamaged wheel flanges that are of correct size and shape for your selected wheel.** Proper wheel flanges support the wheel thus reducing the possibility of wheel breakage. Flanges for cut-off wheels may be different from grinding wheel flanges.
- e) **Do not use worn down wheels from larger power tools.** Wheel intended for larger power tool is not suitable for the higher speed of a smaller tool and may burst.

## Additional Safety Warnings Specific for Abrasive Cutting-Off Operations

- a) **Do not "jam" the cut-off wheel or apply excessive pressure. Do not attempt to make an excessive depth of cut.** Overstressing the wheel increases the loading and susceptibility to twisting or binding of the wheel in the cut and the possibility of kickback or wheel breakage.
- b) **Do not position your body in line with and behind the rotating wheel.** When the wheel, at the point of operations, is moving away from your body, the possible kickback may propel the spinning wheel and the power tool directly at you.
- c) **When wheel is binding or when interrupting a cut for any reason, switch off the power tool and hold the power tool motionless until the wheel comes to a complete stop. Never attempt to remove the cut-off wheel from the cut while the wheel is in motion otherwise kickback may occur.** Investigate and take corrective action to eliminate the cause of wheel binding.
- d) **Do not restart the cutting operation in the workpiece. Let the wheel reach full speed and carefully reenter the cut.** The wheel may bind, walk up or kickback if the power tool is restarted in the workpiece.
- e) **Support panels or any oversized workpiece to minimize the risk of wheel pinching and kickback.** Large workpieces tend to sag under their own weight. Supports must be placed under the workpiece near the line of cut and near the edge of the workpiece on both sides of the wheel.
- f) **Use extra caution when making a "pocket cut" into existing walls or other blind areas.**



The protruding wheel may cut gas or water pipes, electrical wiring or objects that can cause kickback.

- **Always use side handle. Tighten the handle securely.** The side handle should always be used to maintain control of the tool at all times.

## Safety Warnings Specific for Sanding Operations

- a) **Do not use excessively oversized sanding disc paper. Follow manufacturer's recommendations, when selecting sanding paper.** Larger sanding paper extending beyond the sanding pad presents a laceration hazard and may cause snagging, tearing of the disc or kickback.

## Safety Warnings Specific for Polishing Operations

- a) **Do not allow any loose portion of the polishing bonnet or its attachment strings to spin freely. Tuck away or trim any loose attachment strings.** Loose and spinning attachment strings can entangle your fingers or snag on the workpiece.

## Safety Warnings Specific for Wire Brushing Operations

- a) **Be aware that wire bristles are thrown by the brush even during ordinary operation. Do not overstress the wires by applying excessive load to the brush.** The wire bristles can easily penetrate light clothing and/or skin.
- b) **If the use of a guard is recommended for wire brushing, do not allow any interference of the wire wheel or brush with the guard.** Wire wheel or brush may expand in diameter due to work and centrifugal forces.

## Additional Safety Rules for Grinders

- Threaded mounting of accessories must match the grinder spindle thread. For accessories mounted by flanges, the arbor hole of the accessory must fit the locating diameter of the flange. Accessories that do not match the mounting hardware of the power tool will run out of balance, vibrate excessively and may cause loss of control.
- The grinding surface of the centre depressed wheels must be mounted below the plane of the guard lip. An improperly mounted wheel that projects through the plane of the guard lip cannot be adequately protected.
- **Do not use Type 11 (flaring cup) wheels on this tool.** Using inappropriate accessories can result in injury.

## Residual Risks

In spite of the application of the relevant safety regulations and the implementation of safety devices, certain residual risks cannot be avoided. These are:

- Impairment of hearing.
- Risk of personal injury due to flying particles.
- Risk of burns due to accessories becoming hot during operation.
- Risk of personal injury due to prolonged use.
- Risk of dust from hazardous substances.

## Markings on Tool

The following pictograms are shown on the tool:



Read instruction manual before use.



Wear eye protection.

## DATE CODE POSITION (FIG. 1)

The date code (p), which also includes the year of manufacture, is printed into the housing.

Example:

2012 XX XX

Year of Manufacture

## Package Contents

The package contains:

- 1 Angle grinder
  - 1 Guard
  - 1 Side handle(excluding DWE8202T)
  - 1 Flange set
  - 1 Hex key(DWE8212S)
  - 1 Wrench (DWE8202S & DWE8202T)
  - 1 Instruction manual
- Check for damage to the tool, parts or accessories which may have occurred during transport.
  - Take the time to thoroughly read and understand this manual prior to operation.

## Description (fig. 1)



**WARNING:** Never modify the power tool or any part of it. Dam age or personal injury could res ult.

- a. Spindle lock button
- b. Spindle
- c. Side handle(excluding DWE8202T)
- d. Backing flange
- e. Threaded clamp nut
- f. Guard
- g. Slider switch(DWE8202S & DWE8212S)
- g1. Toggle switch(DWE8202T)

### INTENDED USE

The DWE8202S, DWE8202T, DWE8212S, small angle grinders have been designed for professional grinding, sanding, wire brushing, polishing and cutting applications.

**DO NOT** use grinding wheels other than centre depressed wheels and flap discs.

**DO NOT** use under wet conditions or in the presence of flammable liquids or gases.

These heavy-duty angle grinders are professional power tools.

**DO NOT** let children come into contact with the tool. Supervision is required when inexperienced operators use this tool.

- This product is not intended for use by persons (including children) suffering from diminished physical, sensory or mental abilities; lack of experience, knowledge or skills unless they are supervised by a person responsible for their safety. Children should never be left alone with this product.

## Electrical Safety

The electric motor has been designed for one voltage only. Always check that the power supply corresponds to the voltage on the rating plate.



This tool is double insulated; therefore no earth wire is required. Always check that the power supply corresponds to the voltage on the rating plate.

If the supply cord is damaged, it must be replaced by a specially prepared cord available through the DeWALT service organisation.

## Using an Extension Cable

If an extension cable is required, use an approved 3-core extension cable suitable for the power input of this tool (see **Technical Data**).The minimum conductor size is 1.5 mm<sup>2</sup>; the maximum length is 30 m.

When using a cable reel, always unwind the cable completely.

## ASSEMBLY AND ADJUSTMENTS



**WARNING:** *To reduce the risk of serious personal injury, turn tool off and disconnect tool from power source before making any adjustments or removing/installing attachments or accessories. Before reconnecting the tool, depress and release the trigger switch to ensure that the tool is off.*

## Attaching Side Handle (fig. 1)



**WARNING:** *Before using the tool, check that the handle is tightened securely.*

Screw the side handle (c) tightly into one of the holes on either side of the gear case. The side handle should always be used to maintain control of the tool at all times.

## Accessories and Attachments

It is important to choose the correct guards, backing pads and flanges to use with grinder accessories. Refer to chart at the end of this section for information on choosing the correct accessories.

Note: Edge grinding and cutting can be performed with Type 27 wheels designed and specified for this purpose.



**WARNING:** *Accessories must be rated for at least the speed recommended on the tool warning label. Wheels and other accessories running over rated accessory speed may burst and cause injury. Threaded accessories must have a M10 hub (for DWE8202T, DWE8202S, or a M14 hub (for DWE8212S). Every unthreaded accessory must have a 22mm arbor hole. If it does not, it may have been designed for a circular saw and should not be used. Used only the accessories shown in chart at the end of this section. Accessory ratings must be above listed minimum wheel speed as shown on tool nameplate.*

## Mounting Guards (fig. 2)

**WARNING:** To reduce the risk of serious personal injury, turn tool off and disconnect tool from power source before making any adjustments or removing/installing attachments or accessories.

Before reconnecting the tool, depress and release the trigger switch to ensure that the tool is off.



**CAUTION:** Guards must be used with this grinder.

When using the DWE8202S or the DWE8202T or the DWE8212S or grinder for cutting metal or masonry a Type 1 guard MUST be used.

Type 1 guards are available at extra cost from DEWALT distributors.

**NOTE:** Please refer to the **Grinding and Cutting Accessory Chart** at the end of this section to see other accessories that can be used with these grinders.

### MOUNTING CLOSED (TYPE 1) OR STANDARD (TYPE 27) GUARD



**CAUTION:** Turn off and unplug the tool before making any adjustments or removing or installing attachments or accessories. Before reconnecting the tool, turn the switch on and off to ensure that the tool is off.

Hubbed wheels install directly on the M10 (DWE8202T, DWE8202S), M14 (DWE8212S) spindle. Thread of accessory must match thread of spindle.

1. Loosen screw, until the guard lug (k) can rotate freely in the groove (j) on the gear case hub.
2. Rotate guard (f) into desired working position. The guard body should be positioned between the spindle and the operator to provide maximum operator protection.
3. Tighten the screw to secure the guard on the gear case cover. (Fasten torque no less than 2.5 N-M). You should be unable to rotate the guard by hand. Do not operate grinder with a loose guard.
4. To remove the guard, loosen screw and pull up on the guard.



**CAUTION:** Failure to properly seat the wheel before turning the tool on may result in damage to the tool or the wheel.

## Fitting and Removing a Grinding or Cutting Disc (fig. 1, 4, 5)



**WARNING:** Do not use a damaged disc.

1. Place the tool on a table, guard up.
2. Fit the backing flange (d) correctly onto the spindle (b) (fig. 4).
3. Place the disc (n) on the backing flange (d). When fitting a disc with a raised centre, make sure that the raised centre (l) is facing the backing flange (d).
4. Screw the threaded clamp nut (e) onto the spindle (b) (fig. 5):
  - a. The ring on the threaded clamp nut (e) must face towards the disc when fitting a grinding disc (fig. 5A);
  - b. The ring on the threaded clamp nut (e) must face away from the disc when fitting a cutting disc (fig. 5B).
5. Press the spindle lock button (a) and rotate the spindle (b) until it locks in position.
6. Tighten the threaded clamp nut (e) with the wrench or the hex key provided
7. Release the spindle lock.
8. To remove the disc, loosen the threaded clamp nut (e) with the wrench or the hex key provided.

**NOTE:** Edge grinding and cutting can be performed with Type 27 wheels designed and specified for this purpose; 6 mm thick wheels are designed for surface grinding while 3 mm wheels are designed for edge grinding. Cutting can also be performed by using a Type 1 wheel and a Type 1 guard.

The recommended diameter of grinding or cutting disc for the tool is 100mm (DWE8202S, DWE8202T) or 125 mm (DWE8212S).

## Mounting Wire Brushes and Wire Wheels

Wire cup brushes or wire wheels screw directly on the grinder spindle without the use of flanges. Use only wire brushes or wheels provided with a M10 (DWE8202S & DWE8202T) or M14 (DWE8212S) thread hub. A Type 27 guard is required when using wire brushes and wheels.



**CAUTION:** Wear work gloves when handling wire brushes and wheels. They can become sharp.



**CAUTION:** Wheel or brush must not touch guard when mounted or while in use. Undetectable damage could occur to the accessory, causing wires to fragment from accessory wheel or cup.

1. Thread the wheel on the spindle by hand.
2. Depress spindle lock button and use a wrench on the hub of the wire wheel or brush to tighten the wheel.
3. To remove the wheel, reverse the above procedure.

**NOTICE:** Failure to properly seat the wheel hub before turning the tool on may result in damage to tool or wheel.

The recommended diameter of Wire Brushes and Wire Wheels for the tool is 100mm(DWE8202S, DWE8202T) or 125mm(DWE8212S) .

## Fitting and Removing a Backing pad/Sanding sheet

1. Place the tool on a table or flat surface, with the guard facing up.
2. Remove the backing flange (d).
3. Place the rubber backing pad correctly onto the spindle (b).
4. Place the sanding sheet on the rubber backing pad.
5. Screw the threaded clamp nut (e) onto the spindle. The ring on the threaded clamp nut must face towards the rubber backing pad.
6. Press the spindle lock button (a) and rotate the spindle (b) until it locks in position.
7. Tighten the threaded clamp nut (e) with the hex key provided or a two pin spanner.
8. Release the spindle lock.
9. To remove the rubber backing pad, loosen the threaded clamp nut (e) with the hex key provided or a two pin spanner.

The recommended diameter of backing pad/sanding sheet for the tool is 100mm(DWE8202S, DWE8202T) or 125mm(DWE812S) .

## Fitting a Wire Cup Brush

Screw the wire cup brush directly onto the spindle without the use of the spacer and threaded flange.

## 100mm Grinding Wheels

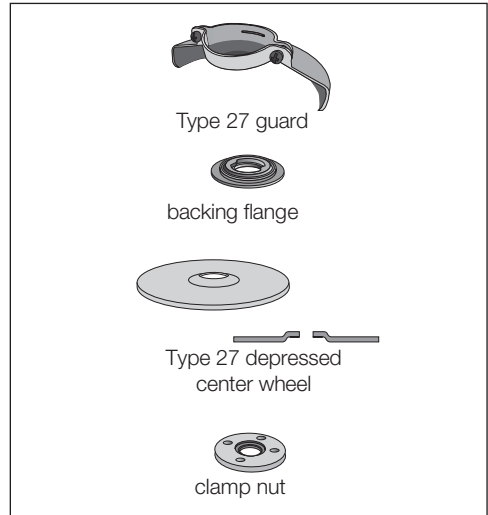

Type 27 guard

backing flange

Type 27 depressed center wheel

clamp nut

## Wire Wheels

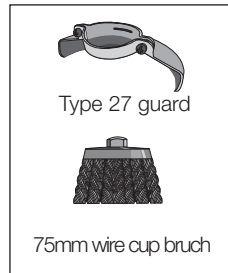

Type 27 guard

75mm wire cup brush

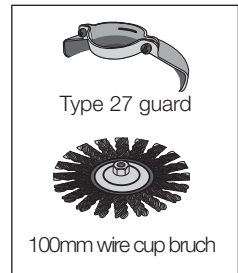

Type 27 guard

100mm wire cup brush

## 100mm Cutting Wheels

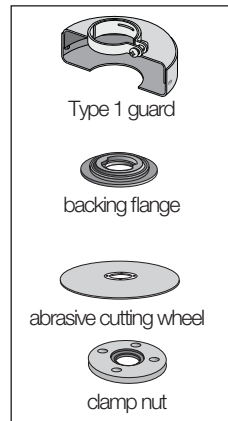

Type 1 guard

backing flange

abrasive cutting wheel

clamp nut

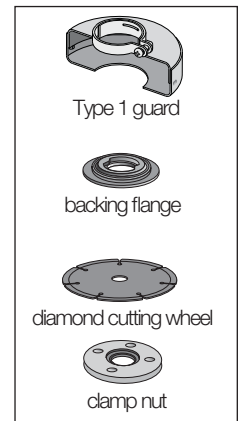

Type 1 guard

backing flange

diamond cutting wheel

clamp nut

## 100mm Sanding Flap Discs

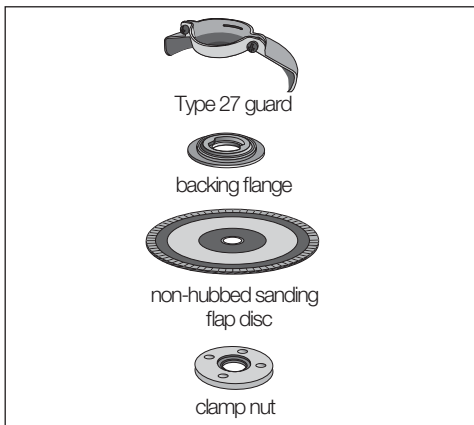

create a hazard and cause personal injury.

- Apply only a gentle pressure to the tool. Do not exert side pressure on the disc.
- Avoid overloading. Should the tool become hot, let it run a few minutes under no load condition.

### Proper Hand Position (fig. 6)



**WARNING:** To reduce the risk of serious personal injury, **ALWAYS** use proper hand position as shown.



**WARNING:** To reduce the risk of serious personal injury, **ALWAYS** hold securely in anticipation of a sudden reaction.

Proper hand position requires one hand on the side handle (figure 1), with the other hand on the body of the tool, as shown in figure 6.

### Prior to Operation

- Install the guard and appropriate disc or wheel. Do not use excessively worn discs or wheels.
- Be sure the inner and outer flanges are mounted correctly.
- Make sure the disc or wheel rotates in the direction of the arrows on the accessory and the tool.

## OPERATION

### Instructions for Use



**WARNING:** Always observe the safety instructions and applicable regulations.



**WARNING:** To reduce the risk of serious personal injury, **turn tool off and disconnect tool from power source before making any adjustments or removing/installing attachments or accessories.** Before reconnecting the tool, depress and release the trigger switch to ensure that the tool is off.



**WARNING:**

- Ensure all materials to be ground or cut are secured in place.
- Secure and support the workpiece. Use clamps or a vice to hold and support the workpiece to a stable platform. It is important to clamp and support the workpiece securely to prevent movement of the workpiece and loss of control. Movement of the workpiece or loss of control may



**CAUTION:** Hold the body of the tool firmly to maintain control of the tool at start up and during use and until the wheel or accessory stops rotating. Make sure the wheel has come to a complete stop before laying the tool down.

**NOTE:** To reduce unexpected tool movement, do not switch the tool on or off while under load conditions. Allow the grinder to run up to full speed before touching the work surface. Lift the tool from the surface before turning the tool off. Allow the tool to stop rotating before putting it down.

### SLIDER SWITCH DWE8202S & DWE8212S (FIG. 3)



**WARNING:** Before connecting the tool to a power supply, be sure the slider switch is in the off position by pressing the rear part of the switch and releasing. Ensure the slider switch is in the off position as described above after any interruption in power supply to the tool, such as the activation of a ground fault interrupter, throwing of a circuit breaker, accidental unplugging, or power failure. If the slider switch is locked on when the power is connected, the tool will start unexpectedly.

To start the tool, slide the slider switch (g) toward the front of the tool. To stop the tool, release the slider switch.

For continuous operation, slide the switch toward the front of the tool and press the forward part of the switch inward. To stop the tool while operating

in continuous mode, press the rear part of the slider switch and release.

**TOGGLE SWITCH DWE8202T (FIG. 3)**



**WARNING:** Before using the tool, check that the handle is tightened securely.

To turn on the tool, lift up the button(g1) to "1" position, to turn off the tool, push the toggle switch Button(g1) to "0" position.



**WARNING:** Do not switch the tool on or off when under load.

**Spindle Lock (fig. 1)**

The spindle lock (a) is provided to prevent the spindle from rotating when installing or removing wheels. Operate the spindle lock only when the tool is turned off, unplugged from the power supply, and has come to a complete stop.

**NOTICE:** To reduce the risk of damage to the tool, do not engage the spindle lock while the tool is operating. Damage to the tool will result and attached accessory may spin off possibly resulting in injury.

To engage the lock, depress the spindle lock button and rotate the spindle until you are unable to rotate the spindle further.

**Metal Applications**

When using the tool in metal applications, make sure that a residual current device (RCD) has been inserted to avoid residual risks caused by metal swarf.

If the power supply is shut off by the RCD, take the tool to authorised DeWALT repair agent.



**WARNING:** In extreme working conditions, conductive dust can accumulate inside the machine housing when working with metal. This can result in the protective insulation in the machine becoming degraded with a potential risk of an electrical shock.

To avoid build-up of metal swarf inside the machine, we recommend to clear the ventilation slots on a daily basis. Refer to **Maintenance**.

**Using Flap Discs**



**WARNING: Metal dust build-up.** Extensive use of flap discs in metal applications can result in the increased potential for electric shock. To reduce this risk, insert an RCD before use and clean the ventilation slots daily by blowing dry compressed air into the ventilation slots in accordance with the below maintenance instructions.

**MAINTENANCE**

Your DeWALT power tool has been designed to operate over a long period of time with a minimum of maintenance. Continuous satisfactory operation depends upon proper tool care and regular cleaning.



**WARNING: To reduce the risk of serious personal injury, turn tool off and disconnect tool from power source before making any adjustments or removing/installing attachments or accessories.** Before reconnecting the tool, depress and release the trigger switch to ensure that the tool is off.

**Pop-off Brushes**

The motor will be automatically shut off indicating that the carbon brushes are nearly worn out and that the tool needs servicing. The carbon brushes are not user-serviceable. Take the tool to an authorised DeWALT repair agent.



**Lubrication**

Your power tool requires no additional lubrication.



**Cleaning**



**WARNING:** Blow dirt and dust out of the main housing with dry air as often as dirt is seen collecting in and around the air vents. Wear approved eye protection and approved dust mask when performing this procedure.



**WARNING:** Never use solvents or other harsh chemicals for cleaning the non-metallic parts of the tool. These chemicals may weaken the materials used in these parts. Use a cloth dampened only with water and mild

soap. Never let any liquid get inside the tool; never immerse any part of the tool into a liquid.

## Optional Accessories



**WARNING:** Since accessories, other than those offered by DEWALT, have not been tested with this product, use of such accessories with this tool could be hazardous. To reduce the risk of injury, only DEWALT recommended accessories should be used with this product.

Consult your dealer for further information on the appropriate accessories.

## Protecting the Environment



Separate collection. This product must not be disposed of with normal household waste.

Should you find one day that your DEWALT product needs replacement, or if it is of no further use to you, do not dispose of it with household waste. Make this product available for separate collection.



Separate collection of used products and packaging allows materials to be recycled and used again. Re-use of recycled materials helps prevent environmental pollution and reduces the demand for raw materials.

Local regulations may provide for separate collection of electrical products from the household, at municipal waste sites or by the retailer when you purchase a new product.

DEWALT provides a facility for the collection and recycling of DEWALT products once they have reached the end of their working life. To take advantage of this service please return your product to any authorised repair agent who will collect them on our behalf.

You can check the location of your nearest authorised repair agent by contacting your local DEWALT office at the address indicated in this manual. Alternatively, a list of authorised DEWALT repair agents and full details of our after-sales service and contacts are available on the Internet at: **[www.2helpU.com](http://www.2helpU.com)**.



# 角磨机

## DWE8202T、DWE8202S、DWE8212S

### 恭喜!

恭喜您选择了 DeWALT 工具。凭借多年的产品开发和创新经验，DeWALT 已经成为专业电动工具用户最可靠的合作伙伴之一。

### 技术参数

		DWE8202T	DWE8202S	DWE8212S
电压	伏特	220-240	220-240	220-240
型号		1	1	1
输入功率	瓦	890	890	890
空载/额定转速	转/分	12000	12000	12000
砂轮直径	毫米	100	100	125
主轴直径		M10	M10	M14
开关类型		摇杆	侧滑	侧滑
重量	千克	1.75*	1.75*	1.95*

\*重量不含侧手柄，电源线，含护罩和法兰。

### 定义：安全准则

下列定义解释了各警示词的严重程度。请仔细阅读本手册，并注意这些警示符号。



**危险：**表示存在紧急危险情况，如果不加以避免，将导致死亡或严重伤害。



**警告：**表示存在潜在危险情况，如果不加以避免，可能导致死亡或严重伤害。



**警示：**表示存在潜在危险情况，如果不加以避免，可能导致轻度或中度伤害。

**注意：**表示不涉及人身伤害的情况，如果不加以避免，可能导致财产损失。



表示存在触电危险。



表示存在火灾危险。



**警告：**为降低伤害风险，请阅读使用手册。

### 电动工具一般安全警告



**警告！**请仔细阅读所有安全警告和指示说明。如果不遵守下列警告和指示，则可能会导致触电，火灾和/或严重伤害。

### 请保存所有警告和指示，以备将来查阅。

警告中的术语“电动工具”是指市电驱动（有线）电动工具、或由电池驱动（无线）电动工具。

#### 1) 工作场地安全

- 保持工作场地清洁和明亮。杂乱和黑暗的地方会引发事故。
- 不要在易爆环境，如有易燃液体、气体或粉尘的环境下操作电动工具。电动工具产生的火花会点燃粉尘或气体。
- 让儿童和旁观者离开后操纵电动工具时，分心或使你放松控制。

#### 2) 电气安全

- 电动工具插头必须与插座相匹配。绝不能以任何方式改装插头。需接地的电动工具不能使用任何转换插头。未经改装的插头与相配的插座将减少触电风险。
- 避免人体接触接地表面，如管道、散热片和冰箱等。如果您身体接地，会增加触电危险。
- 不得将电动工具暴露在雨中或潮湿环境中。水进入电动工具将增加触电危险。
- 切勿滥用电线。绝不能用电线搬运、拉动电动工具或拔出其插头。让电动工具远离热、油、锐边或运动部件。受损或缠绕的电线会增加触电危险。



- e) 当在户外使用电动工具时，使用适合户外使用的外接电线。适合户外使用的电线会降低触电危险。
- f) 如果必须在潮湿的地方操作电动工具，请使用漏电保护器 (RCD)。使用 RCD 可降低触电危险。
- g) 按照使用说明书以及打算使用的电动工具的特殊类型要求的方式，考虑作业条件和进行的作业来使用电动工具、附件和工具的刀头等。将电动工具用作那些与要求不符的操作可能会导致危险情况。

### 5) 维修

- a) 将你的电动工具送交专业维修人员，必须使用同样的备件进行更换。这样将确保所维修的电动工具的安全性。

## 附加安全细则

### 所有操作的使用说明

- a) 该电动工具是用于实现砂轮机或切断工具功能的。阅读随该电动工具提供的所有安全警告、说明、图解和规定。不了解以下所列所有说明将导致电击、着火和/或严重伤害。
- b) 不推荐用该电动工具进行诸如砂光、钢丝刷、抛光等操作。电动工具不按指定的功能去操作，可能会发生危险和引起人身伤害。
- c) 不使用非工具制造商推荐和专门设计的附件。否则该附件可能被装到你的电动工具上，而它不能安全操作。
- d) 附件的额定转速必须至少等于电动工具上标出的最大速度。附件以比其额定转速大的速度运转会发生爆裂和飞溅。
- e) 附件的外径和厚度必须在电动工具额定能力范围内。不正确的附件尺寸不能得到充分保护或控制。
- f) 砂轮、法兰盘、靠背垫或任何其他附件的轴孔尺寸必须适合于安装到电动工具的主轴上。带轴孔、与电动工具安装件不配的附件将会失稳、过度振动并会引起失控。
- g) 不要使用损坏的附件。在每次使用前要检查附件，例如砂轮是否有碎片和裂痕，靠背垫是否有裂缝、撕裂或过度磨损，钢丝刷是否松动或金属丝是否断裂。如果电动工具或附件脱落了，检查是否有损坏或安装没有损坏的附件。检查和安装附件后，让自己和旁观者的位置远离旋转附件的平面，并以电动工具最大空载转速运行一分钟。破损的附件通常在该试验时会碎裂。
- h) 戴上防护用品。根据适用情况，使用面罩、安全护目镜或安全眼镜。适用时，戴上防尘面具、听力保护器、手套和能挡小磨料或工件碎片的工作围裙。眼防护罩必须挡住各种操作产生的飞屑。防尘面具或口罩必须能够过滤操作产生的颗粒。长期暴露在高强度噪声中会引起失聪。
- i) 让旁观者与工作区域保持一定安全距离。任何

### 3) 人身安全

- a) 保持警觉。当操作电动工具时，关注所从事的操作并保持清醒。切勿在疲倦、药物、酒精或治疗反应下使用电动工具。在操作电动工具期间精力分散会导致严重的人身伤害。
- b) 使用安全装置。始终佩戴防护目镜。安全装置，例如适当条件下的防尘面具、防滑安全鞋、安全帽、听力防护等装置能减少人身伤害。
- c) 避免突然启动。确保开关在插入插头时处以关断位置。手指放在已接通电源得开关上，或开关处于接通时插入插头可能会导致危险。
- d) 在电动工具接通之前，拿下所有调整钥匙或扳手。遗留在电动工具旋转零件上的扳手或钥匙会导致人身伤害。
- e) 手不要伸得太长。时刻注意脚下和身体平衡。这样在意外情况下能更好地控制电动工具。
- f) 着装适当。不要穿宽松衣服或佩戴饰品。让您的头发、衣服和袖子远离运动部件。宽松的衣服、配饰或长发可能会卷入运动部件中。
- g) 如果提供了与排屑装置、集尘设备连接用的装置，则确保这些装置连接完好且使用得当。使用这些装置可减少碎屑引起的危险。

### 4) 电动工具的使用和注意事项

- a) 不要乱用电动工具。根据用途选用适当的电动工具。选用适当的设计额定值的电动工具会使你工作更有效、更安全。
- b) 如果开关不能接通或关断工具电源，则不能使用该电动工具。不能用开关控制的电动工具是危险的，必须进行修理。
- c) 在进行任何调节、更换附件或贮存电动工具之前，必须从电源上拔掉插头和/或将电池盒脱离电源。这种防护性措施将减少电动工具突然启动的危险。
- d) 将闲置电动工具贮存在儿童所及范围之外，并且不要让不熟悉电动工具或对这些说明书不了解的人操作电动工具。电动工具在未经训练的用户手中是危险的。
- e) 保养电动工具。检查运动部件的偏差或卡住、零件破损情况和影响电动工具运行的其他条件。如有损坏，电动工具必须在使用前修理好。许多事故由维护不良的电动工具引发。
- f) 保持切削刀具锋利和清洁。保养良好的有锋利切削刃的刀具不易卡住而且容易控制。

进入工作区域的人必须戴上防护用品。工件或破损附件的碎片可能会飞出并引起紧靠着操作区域的旁观者的伤害。切割附件触及带电导线会使电动工具外漏的金属零件带电，并使操作者触电。

- j) 当在切割附件有可能切割到暗线或自身电线的场所进行操作时，只能通过绝缘握持面来握住电动工具。切割附件碰到一根带电导线会使电动工具外露金属零件带电并使操作者发生电击危险。
- k) 使软线远离旋转的附件。如果控制不当，软线可能被切断或缠绕，并使得你的手或手臂可能被卷入旋转附件中。
- l) 直到附件完全停止运动才放下电动工具。旋转的附件可能会抓住表面并拉动电动工具而让你失去对工具的控制。
- m) 当携带电动工具时不要开动它。意外地触及旋转附件可能会缠绕你的衣服而使附件伤害身体。
- n) 经常清理电动工具的通风口。电动机风扇会将灰尘吸进机壳，过多的金属粉尘沉积会导致电气危险。
- o) 不要在易燃材料附近操作电动工具。火星可能会点燃这些材料。
- p) 不要使用需用冷却液的附件。用水或其他冷却液可能会导致电腐蚀或电击。

## 对所有操作的进一步安全说明

### 反弹和相关警告：

反弹是因卡住或缠绕住的旋转砂轮、靠背垫、钢丝刷或其他附件而产生的突然反作用力。卡住或缠绕会引起转动附件的迅速堵转，随之使失控的电动工具在卡住点产生与附件旋转方向相反的运动。

例如，如果砂轮被工件缠绕或卡住，伸入卡住点的砂轮边缘可能会进入材料表面而引起砂轮爬出或反弹。砂轮可能会飞向或飞离操作者，这取决于砂轮在卡住点的运动方向。在此条件下砂轮也可能会碎裂。

反弹是电动工具误用和/或不正确的操作工序或条件的结果。可以同工采取以下给出的适当预防措施得以避免：

- a) 保持紧握电动工具，使您的身体和手臂处于正确状态以抵抗反弹力。如有辅助手柄，则要坚持使用，以便最大限度地控制住起动时的反弹力或反力矩。如采取合适的预防措施，操作者就可以控制反力矩或反弹力。
- b) 绝不能将手靠近转动附件。附件可能会反弹碰到手。
- c) 不要站在发生反弹时电动工具可能移动到的地

方。反弹将在缠绕点驱使工具逆砂轮运动方向运动。

- d) 当在尖角、锐边等处作业时要特别小心。避免附件的弹跳和缠绕。尖角、锐边和弹跳具有缠绕旋转附件的并引起反弹的失控。
- e) 不要安装上锯链、木雕锯片或带齿锯片。这些锯片会产生频繁的反弹和失控。

## 砂磨和切割操作的附加安全说明

### 对磨削和砂磨切割操作的专用安全警告：

- a) 只使用所推荐的砂轮型号和为选用砂轮专门设计的护罩。不是为电动工具设计的砂轮不能充分得到保护，是不安全。
- b) 护罩必须牢固地装在电动工具上，且放置得最具安全性，只有最小的砂轮部分暴露在操作人面前。护罩帮助保护操作者免于受到爆裂砂轮碎片和偶然触及砂轮的危险。
- c) 砂轮只用作推荐的用途。例如：不要用切割砂轮的侧面进行磨削。施加到砂轮侧面的力可能会使其碎裂。
- d) 始终为所选砂轮选用未损坏的、有恰当规格和形状的砂轮法兰盘。合适的砂轮法兰盘支撑砂轮可以减小砂轮破裂的可能性。切割砂轮的法兰盘可以不同于砂轮的法兰盘。
- e) 不要使用从大规格电动工具上用剩的磨损砂轮。用于大规格电动工具上的砂轮不适用于较小规格工具的高速工况并可能会爆裂。

## 切割操作的附加安全说明

### 对砂轮切割操作的附加专用安全警告

- a) 不要“夹”住切割砂轮或施加过大的压力。不要试图过深地切割。给砂轮施加过应力增加了砂轮在切割时的负载，容易缠绕或卡住，增加了反弹或砂轮爆裂的可能性。
- b) 身体不要对着旋转砂轮，也不要站在其后。当把砂轮从操作者身边的操作点移开时，可能的反弹可能会使旋转砂轮和电动工具朝你推来。
- c) 当砂轮被卡住或无论任何原因而中断切割时，关掉电动工具并握住工具不要动，直到砂轮完全停止。绝不要试图当砂轮仍然运转时使切割砂轮脱离切割，否则会发生反弹。调查并采取校正措施以消除砂轮卡住的原因。
- d) 不能在工件上重新起动切割操作。让砂轮达到全速后再小心地重新进入切割。如果电动工具在工件上重新起动，砂轮可能会卡住、爬出或

回弹。

- e) 支撑住板材或超大工件可使得砂轮卡住和反弹的危险降到最低限度。大工件凭借自重而下垂。必须在工件靠近切割线处和砂轮两侧近工件边缘处放置支撑。
- f) 当进行“盲切割”进入墙体或其他盲区时要格外小心。伸出的砂轮可能会割到煤气管或水管，电线或由此引起反弹的物体。

## 角磨机的附加安全细则

- 附件的螺纹安装必须与角磨机主轴螺纹相配。对于通过法兰安装的附件，附件的轴孔必须适合法兰的定位直径。与电动工具安装件不相配的附件将失衡、过度震动并会引起失控。
- 中心凹陷的砂轮的磨削表面必须安装在护罩边缘平面的下方。安装不当且穿过护罩边缘平面的砂轮得不到充分保护。
- 禁止在本工具上使用 11 型号（杯形）砂轮。使用不合适的附件可能会导致伤害。
- 建议使用侧手柄。牢固地拧紧手柄。应始终使用侧手柄，以时刻保持对工具的控制。

## 剩余风险

尽管遵守了相关的安全法规并采用了安全装备，某些剩余风险仍然是无法避免的。这些风险包括：

- 听力损伤。
- 飞散颗粒造成的人身伤害风险。
- 操作过程中附件加热而产生的烧伤危险。
- 长时间使用引起的人身伤害。
- 危害物质粉尘引起的风险。

## 工具上的标识

工具有下列标志：



使用前请阅读使用手册。



请佩戴护目装备。

### 日期码位置（图 1）

包含制造年份的日期码 (p) 印在工具外壳上。

例如：

2012 XX XX

制造年份

## 包装内容

本产品包装内含有：

- 1 角磨机
- 1 护罩
- 1 侧手柄（除了 DWE8202T 以外）
- 1 法兰套件
- 1 内六角扳手（DWE8212S）
- 1 扳手（DWE8202S 和 DWE8202T）
- 1 使用手册
- 检查工具、部件或附件是否在运输过程中损坏。
- 操作前请花时间仔细阅读和理解本手册。

## 描述（图 1）



**警告：**禁止改装电动工具或其任何部分，否则可能导致损坏或人身伤害。

- a. 主轴锁按钮
- b. 主轴
- c. 侧手柄（除了 DWE8202T 以外）
- d. 靠背法兰
- e. 螺纹紧固螺母
- f. 护罩
- g. 侧滑开关（DWE8202S 和 DWE8212S）
- g1. 摇杆开关（DWE8202T）

### 预期用途

DWE8202S、DWE8202T、DWE8212S

小型角磨机设计用于专业磨削和切割。

禁止使用中心凹陷砂轮以外的砂轮。

禁止在潮湿环境中或在有易燃液体或气体的环境中使用本工具。

本重型角磨机是专业型电动工具。

不得让儿童接触本工具。缺乏经验的操作人员需要在监督下使用本工具。

本产品不适合体力、感官或智力不足以及缺乏经验、知识或技能的人员（包括儿童）使用，除非一旁有能为他们的安全负责的监督人员。不得在无人监管的情况下让儿童触及本产品。

## 电气安全

电机只适用一种工作电压。请确认电源电压是否与标牌上标明的电压一致。



本工具采用双重绝缘，因此无需接地线。请务必检查电源是否与铭牌上的电压一致。

电源线损坏时必须采用 DeWALT 服务机构专门制备的电线更换。

## 使用延长电缆

如需使用延长电缆，请使用与本工具的输入电源（见技术参数）相符且经检验的 2 芯延长电缆。导体的最小尺寸为 1.5 平方毫米，最大长度为 30 米。

当使用电缆卷筒时，请务必完全卷出电缆。

## 组装和调整



**警告：**为降低严重的人身伤害风险，在进行任何调整或取出/安装配件或附件之前，请关闭工具电源和断开工具电源连接。重新连接工具之前，请按下并松开触发开关以确保工具已关闭。

## 安装侧手柄（图 1）

（除了 DWE8202T 以外）



**警告：**使用工具之前，请检查手柄是否牢固拧紧。

将侧手柄 (c) 牢固地旋入齿轮箱任一侧的其中一个孔中。应始终使用侧手柄，以时刻保持对工具的控制。

## 附件和配件

务必选择正确的护罩、靠背垫和法兰以与角磨机附件配合使用。请参阅本节结束处的图表，获取有关选择正确附件的信息。

注：边缘磨削和切割可采用专为此用途设计的 27 型号砂轮进行。



**警告：**附件的额定转速必须至少等于工具警告标签上建议的转速。砂轮和其他附件以比其额定转速大的速度运转可能会引发爆裂并可能会导致伤害。螺纹附件必须具有 M10 轮毂（适用于 DWE8202T、DWE8202S）或 M14 轮毂（适用于 DWE8212S）。每个非螺纹附件必须具有一个 22 毫米的轴孔。如果没有，则可能是专为电圆锯设计，此处不应该使用此类附件。仅使用本节结束处图表中所示的附件。附件额定值必须大于工具标牌中所列的最小砂轮转速。

## 安装护罩（图 2）

**警告：**为降低严重的人身伤害风险，在进行任何调整或取出/安装配件或附件之前，请关闭工具电源和断开工具电源连接。重新连接工具之前，请按下并松开触发开关以确保工具已关闭。



**警告：**护罩必须与本角磨机一同使用。

将 DWE8202S 或 DWE8202T 或 DWE8212S 角磨机用于切割金属或砖石时，必须使用 1 型号型号护罩。1 型号护罩可从 DeWALT 经销商处另行购买。

注：请参阅本节结束处的磨削和切割附件图表，查看可与本角磨机配合使用的其他附件。

### 安装封闭式（1 型号）或标准（27 型号）护罩



**警告：**关闭工具的电源并拔出插头，然后调整、拆除或安装配件或附件。重新连接工具之前，请打开开关，然后将其关闭以确保工具已关闭。

带轮毂的砂轮直接安装在 M10（DWE8202T、DWE8202S）或 M14（DWE8212S）主轴上。附件的螺纹必须与主轴的螺纹相配。

1. 旋松螺丝，直到护罩接片 (k) 可以在齿轮箱轮毂上的凹槽 (j) 中自由转动。
2. 将护罩 (f) 旋转入所需的工作位置。护罩主体应位于主轴与操作人员之间，为操作人员提供最大保护。
3. 拧紧螺丝，将护罩固定在齿轮箱盖上。（紧固扭矩不小于 2.5 N·M）。无法用手转动护罩。切勿操作护罩松动的角磨机。
4. 若要移除护罩，请旋松螺丝并将其从护罩中拔出。



**警告：**如果开启工具前未能正确放置砂轮，可能会对工具或砂轮造成损坏。

## 安装和拆除磨削或切割圆盘（图 1、4、5）



**警告：**禁止使用破损圆盘。

1. 将工具放置在工作台上，护罩朝上。
2. 将靠背法兰 (d) 正确安装到主轴 (b) 上（图 4）。
3. 将圆盘 (n) 放置在靠背法兰 (d) 上。安装中心凸起的圆盘时，确保凸起的中心 (l) 面向靠背法兰 (d)。
4. 将螺纹紧固螺母 (e) 旋入主轴 (b)（图 5）：
  - a. 安装磨削圆盘时，螺纹紧固螺母 (e) 上的圆环必须面向圆盘（图 5A）；
  - b. 安装切割圆盘时，螺纹紧固螺母 (e) 上的圆环必须背向圆盘（图 5B）。

- 按下主轴锁按钮 (a) 并转动主轴 (b), 直到其锁定到位。
- 使用随附的扳手或六角键拧紧螺纹紧固螺母 (e)
- 松开主轴锁。
- 若要拆除圆盘, 请使用随附的扳手或六角键松开螺纹紧固螺母 (e)。

**注:** 边缘磨削可采用专为此用途设计的 27 型号砂轮进行; 6 毫米厚的砂轮用于表面磨削, 而 3 毫米厚的砂轮用于边缘磨削。切割也可以采用 41 型号砂轮和 41 型号护罩进行。

工具的磨削圆盘的直径建议为 125 毫米 (切割仅适用于 DWE8212S)。

## 砂轮磨片

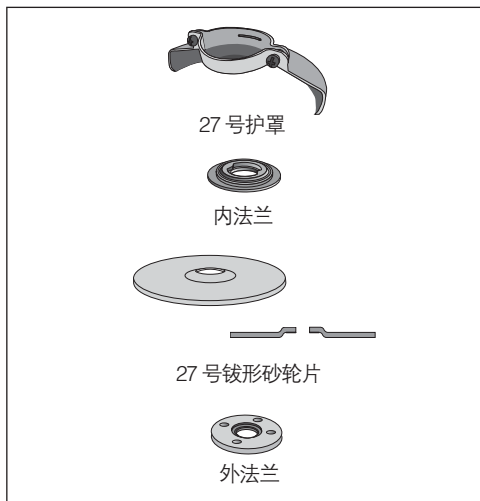

## 切割片

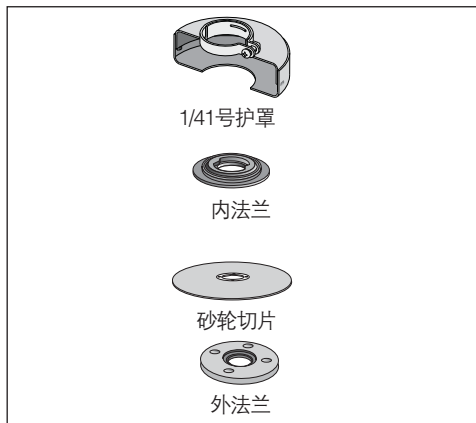

## 使用前的准备工作

- 安装护罩及合适的圆盘或砂轮。禁止使用过度磨损的圆盘或砂轮。
- 确保内部和外部法兰已正确安装。
- 确保圆盘或砂轮按附件和工具上的箭头方向转动。

## 操作

### 使用说明



**警告:** 请务必遵守安全指示和适用的法规。



**警告:** 为降低严重的人身伤害风险, 在进行任何调整或取出/安装配件或附件之前, 请关闭工具电源和断开工具电源连接。重新连接工具之前, 请按下并松开触发开关以确保工具已关闭。



**警告:**

- 确保所有要磨削或切割的材料已固定到位。
- 固定并支撑工件。使用夹具或老虎钳夹紧工件, 并将其支撑在稳定的平台上。务必牢固地夹住和撑住工件以防止工件移动和失控。工件移动或失控可能会引发危险并导致人身伤害。
- 轻轻地对工具施加压力。切勿对圆盘施加侧压力。
- 避免过载。如果工具变得灼热, 请让它在空载情况下运转几分钟。



## 正确的手持方式 (图 6)



**警告:** 为降低严重的人身伤害风险, 请始终使用正确的手持方式, 如图所示。



**警告:** 为降低严重的人身伤害风险, 预期有突然反应时务必紧握住工具。

正确的手持方式要求一只手握住侧手柄 (图 1), 另一只手握住工具主体, 如图 6 所示。

## 开关



**警告:** 紧握工具主体以在启动时和使用过程中保持对工具的控制, 直到砂轮或附件停止转动。确保砂轮完全停止后才放下工具。

**注:** 若要减少工具意外移动, 请勿在负载情况下开启或关闭工具。允许角磨机运转达到全速后再接触工作表面。从工作表面提起工具, 然后再关闭工具。允许工具停止转动后再将其放下。

### 侧滑开关 DWE8202S 和 DWE8212S (图 3)



**警告:** 将工具连接到电源之前, 按下侧滑开关的后部, 然后松开, 确保开关处于关闭位置。在工具的电源出现中断后, 如激活接地故障断路器、丢弃断路器、意外拔下插头或断电, 如上面所述确保侧滑开关处于关闭位置。如果连接电源后侧滑开关锁定为开启状态, 工具将会意外启动。

若要启动工具, 请将侧滑开关 (g) 滑向工具的前方。若要停止工具, 请松开侧滑开关。

要使工具连续运行, 请将开关滑向工具的前方并向内按开关的前部。若要在连续运行模式停止工具, 请按下侧滑开关的后部, 然后松开。

### 摇杆开关 DWE8202T (图 3)



**警告:** 使用工具之前, 请检查手柄是否牢固拧紧。

若要开启工具, 请将按钮 (g1) 提起至 "1" 位置; 若要关闭工具, 请将摇杆开关按钮 (g1) 推至 "0" 位置。



**警告:** 请勿在负载情况下开启或关闭工具。

## 主轴锁 (图 1)

主轴锁 (a) 可在安装或拆除砂轮时防止主轴转动。只能在工具关闭、拔出电源插头且完全停止时使用主轴锁。

**注意:** 为了降低工具损坏的风险, 请勿在工具运行时使用主轴锁。否则将损坏工具, 附着的附件可能会甩脱, 从而导致伤害。

若要使用主轴锁, 请按下主轴锁按钮并转动主轴, 直到无法再转动为止。

## 金属应用

将工具用于金属时, 确保已插入漏电保护器 (RCD) 以避免金属屑导致的剩余风险。

如果 RCD 切断电源, 请将工具送交 DEWALT 授权维修代理。



**警告:** 在极端工作条件下, 处理金属时, 机壳内部可能会积聚导电粉尘。这可能导致机器中的保护绝缘变弱, 可能有触电的危险。

若要避免在机器内部积聚金属屑, 我们建议每天清洁通风槽。请参阅维护。

## 维护

您的 DEWALT 电动工具设计精良, 可以长期使用, 而且只需最少的维护。若要连续、有效的操作, 需要进行适当的工具维护和定期清洁。



**警告:** 为降低严重的人身伤害风险, 在进行任何调整或取出/安装配件或附件之前, 请关闭工具电源和断开工具电源连接。重新连接工具之前, 请按下并松开触发开关以确保工具已关闭。

## 自停式碳刷

电机将自动关闭, 指示碳刷快磨完, 工具需要维修。碳刷不可由用户自行维修。请将工具送交 DEWALT 授权维修代理。



## 润滑

本电动工具无需另行润滑。



## 清洁



**警告：**一旦通风口和周围积聚了可见的粉尘，请立即用干燥的空气吹走主机外壳内的粉尘和灰尘。执行此过程时，需戴上经认可的护目装备和防尘面具。



**警告：**切勿使用溶剂或其他烈性化学制品来清洁工具的非金属部件。这些化学物质可能会削弱这些部位使用的材料。请用布蘸温和的肥皂水擦拭。切勿让任何液体进入工具，切勿让工具的任何部分在液体中浸泡。

## 可选附件



**警告：**除了 DEWALT 提供的附件之外，其他附件都未经此产品兼容性测试，因此本工具若使用此类附件将存在安全隐患。为降低伤害风险，本产品只可使用 DEWALT 推荐的附件。

请向您的经销商咨询更多关于合适附件的信息。

## 环境保护



单独收集。本产品不得与普通家庭垃圾一起处理。

如果您发现您的 DEWALT 产品需要更换或您已经不再需要使用这些产品，请不要将它们与家庭垃圾一起处理。请将它们单独收集。



单独收集使用过的产品和包装能够让材料得以再循环和再利用。再生材料的再利用有助于防止环境污染，并降低对原材料的需求。

当地法规可能要求由市政废物处理点或向您出售新产品的零售商提供从家庭中单独收集电器产品的服务。

DEWALT 提供设施收集和回收使用寿命到期的 DEWALT 产品。若要享受这项服务，请将产品送回任一授权维修代理，他们将代表我们回收您的产品。

请根据本手册所提供的地址与当地 DEWALT 办事处联系，查询离您最近的授权维修代理的位置。或者，您也可以登陆以下网站查询 DEWALT 授权维修代理名单，以及我们售后服务和联系方式的详细信息，网址是：[www.2helpU.com](http://www.2helpU.com)。

制造商：百得美国公司

地址：701 E Joppa Rd, TW050 MD21286,

Towson, 美国

产地：江苏苏州

