

DEWALT®

www.DEWALT.com

DWE7492

English (*original instructions*)

7

繁體中文

21

Fig. A

圖 A

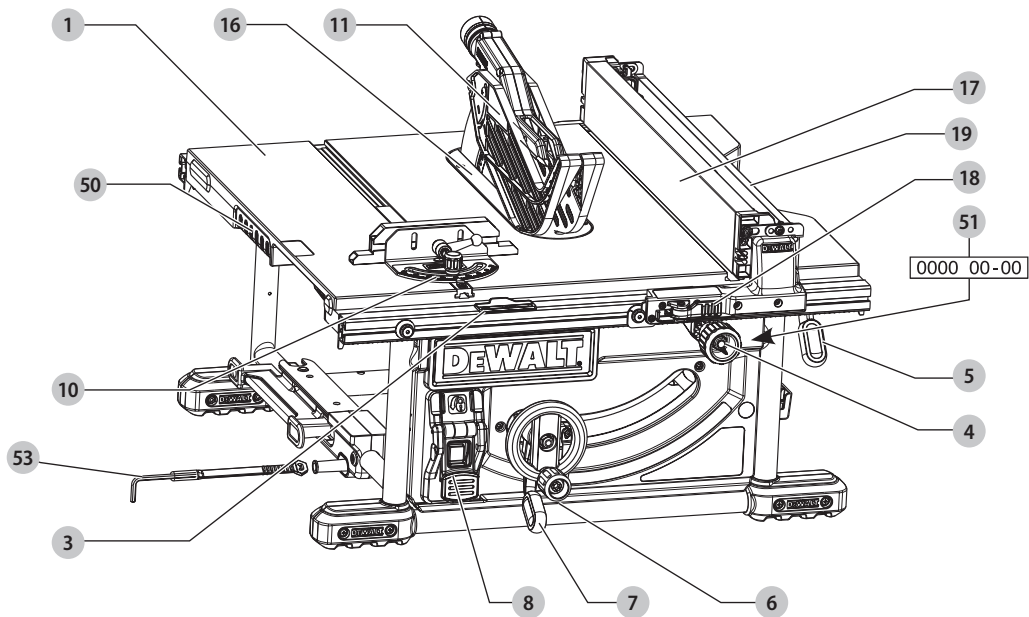

Fig. B

圖 B

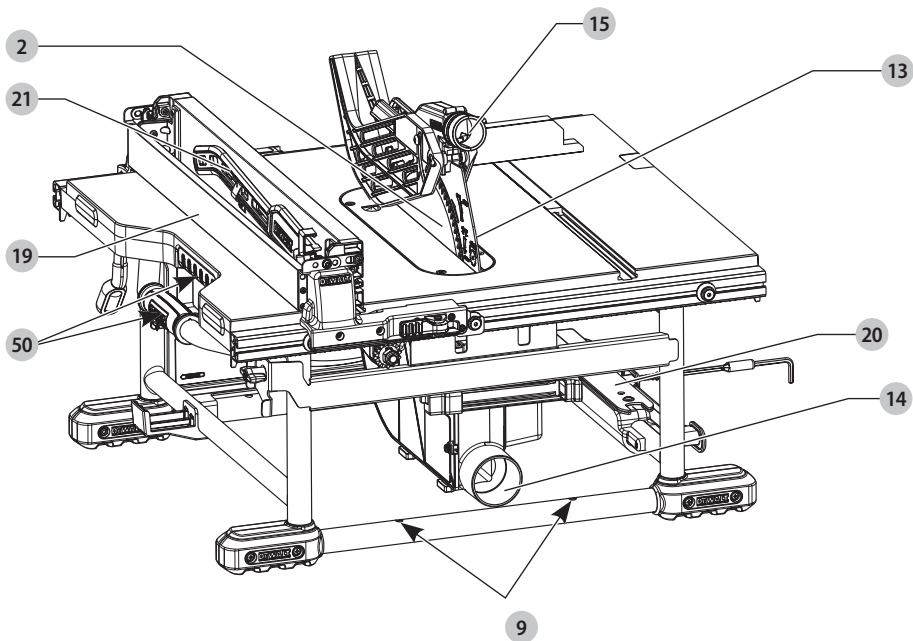

Fig. C
圖 C

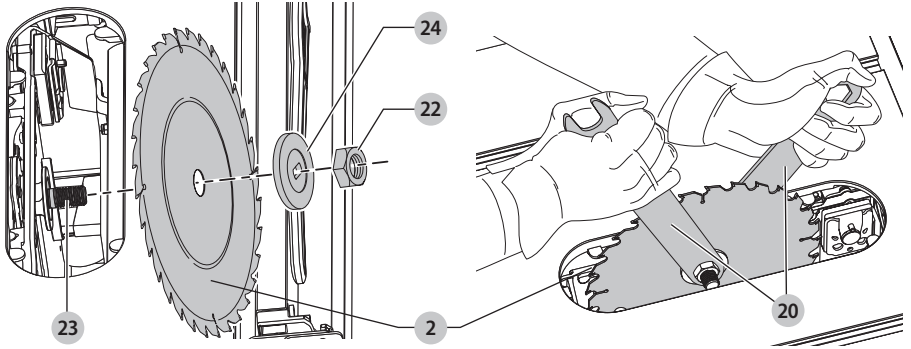

Fig. D
圖 D

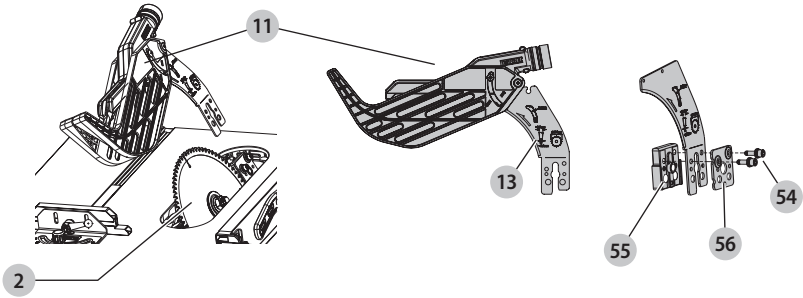

Fig. E
圖 E

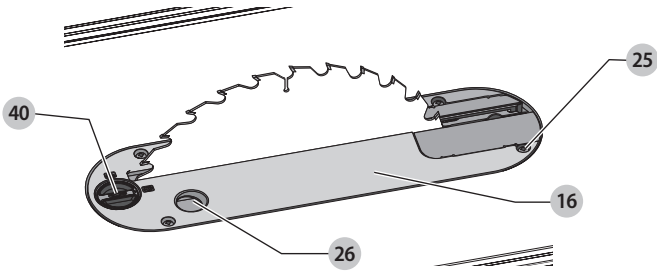

Fig. F
圖 F

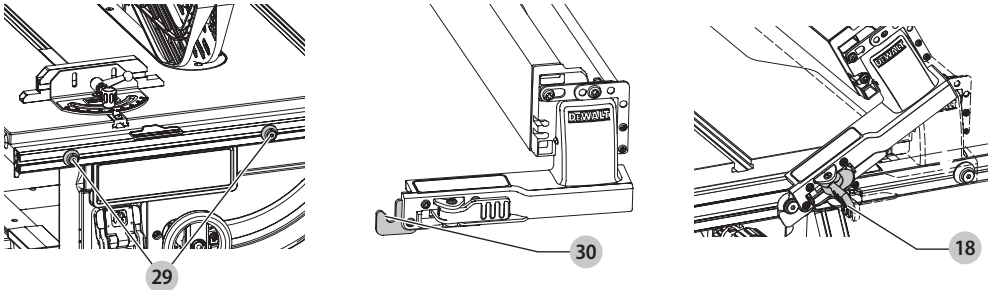

Fig. G
圖 G

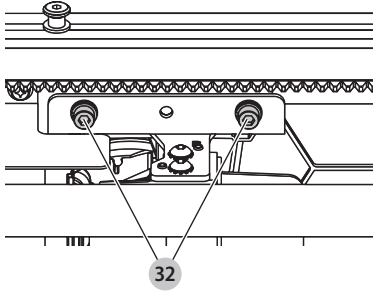

Fig. H
圖 H

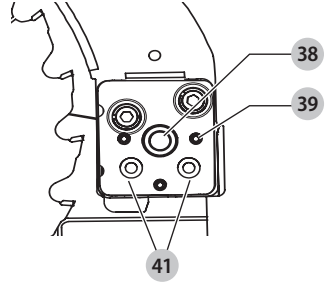
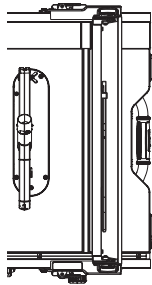
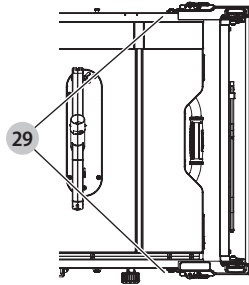

Fig. I
圖 I



Position 1
位置 1



Position 2
位置 2

Fig. J
圖 J

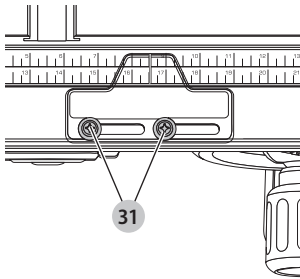

Fig. K
圖 K

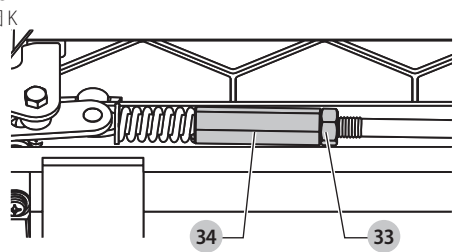

Fig. L
圖 L

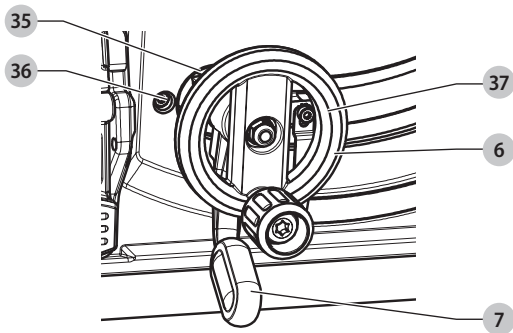

Fig. M
圖 M

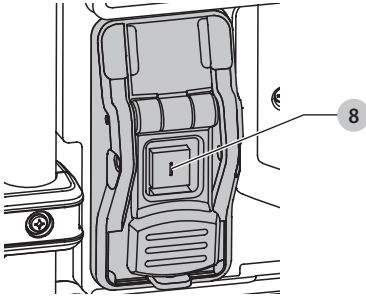

Fig. N
圖 N

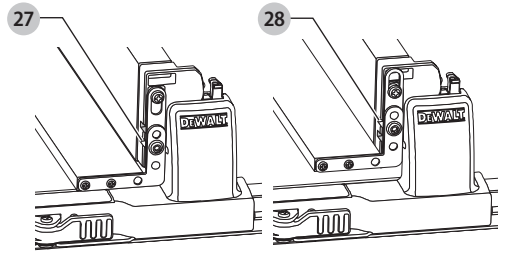

Fig. O
圖 O

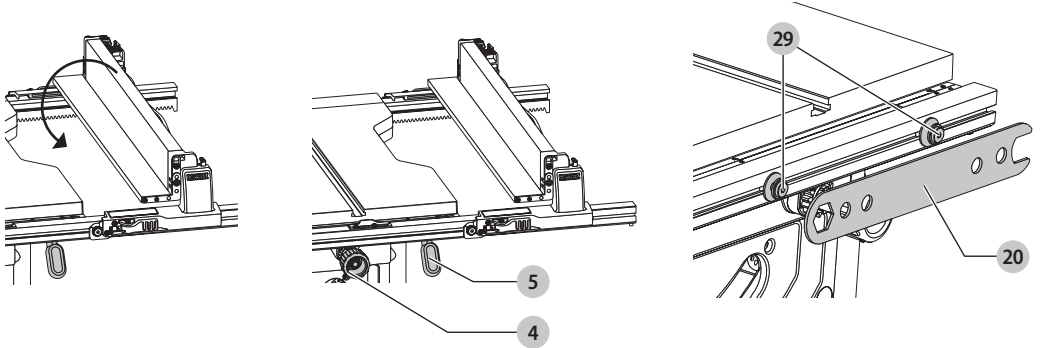

Fig. P
圖 P

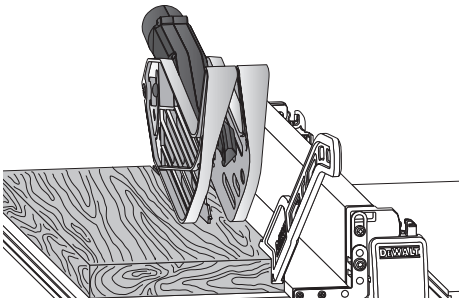

Fig. Q
圖 Q

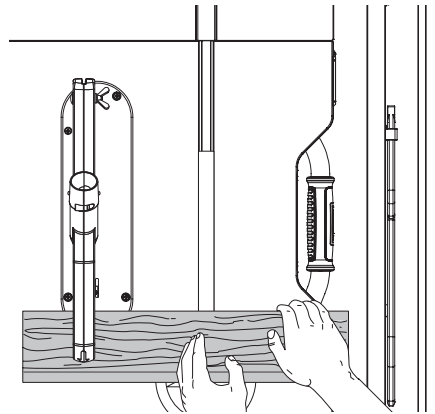

Fig. R
圖 R

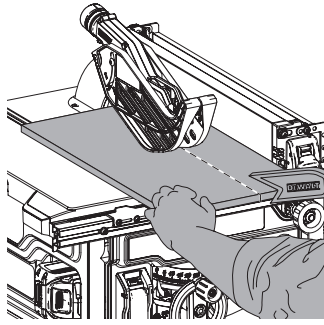

Fig. S
圖 S

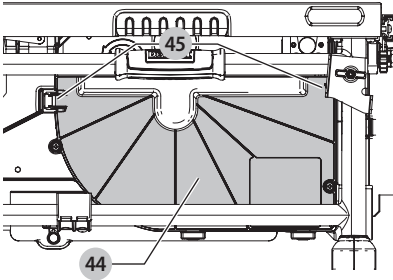

Fig. T
圖 T

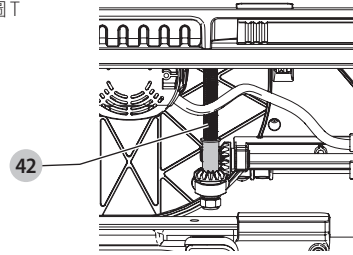

Fig. U
圖 U

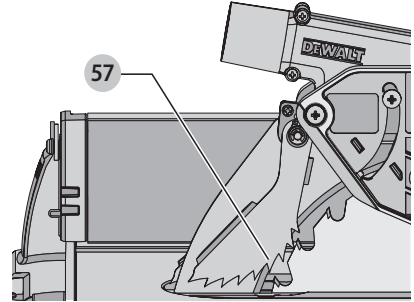
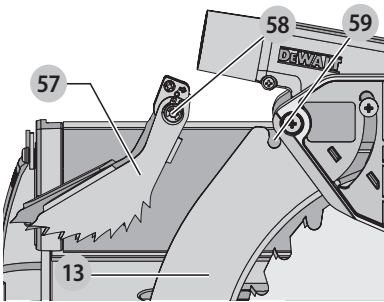
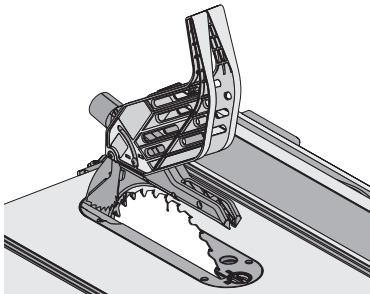
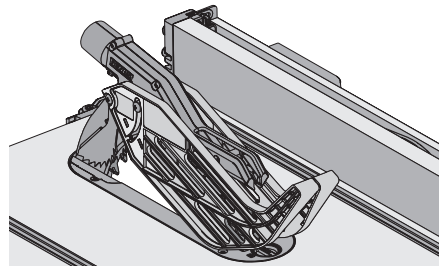

Fig. V
圖 V



RAISED POSITION
抬起位置



OPERATING POSITION
操作位置

Fig. W

圖 W

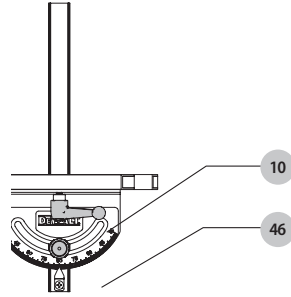
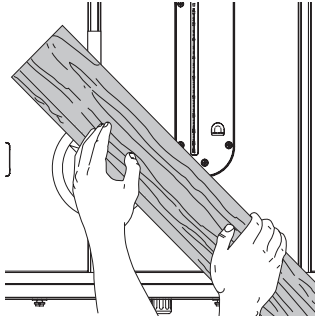

Fig. X

圖 X

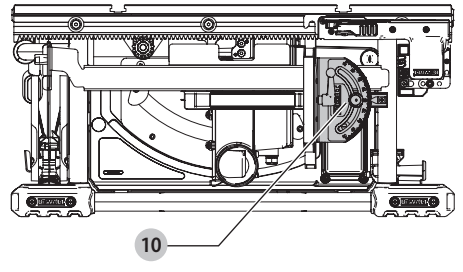
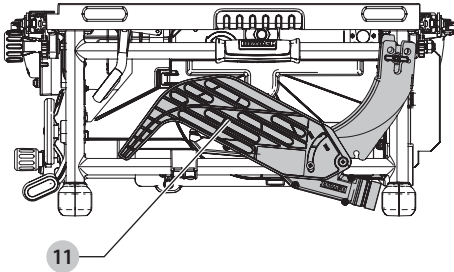

Fig. Y

圖 Y

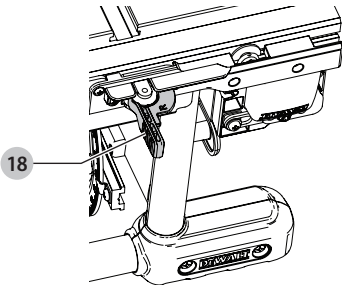

Fig. Z

圖 Z

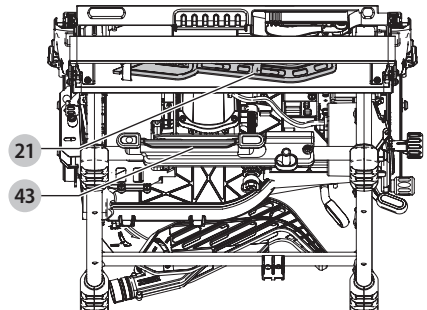

Fig. AA

圖 AA

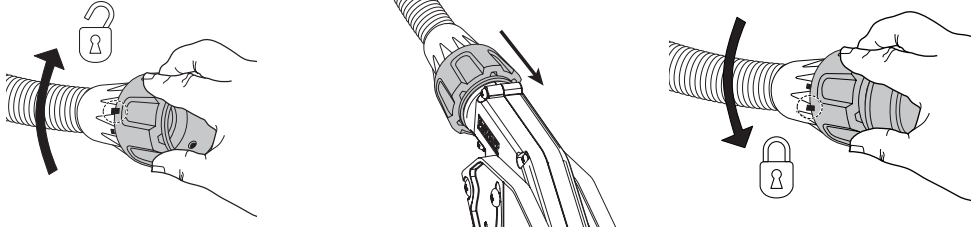

Fig. BB

圖 BB

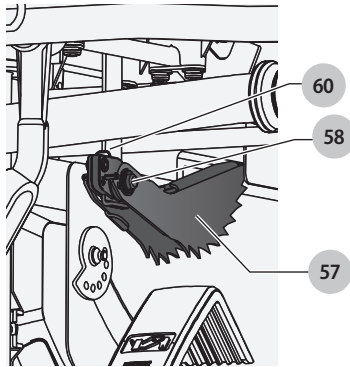

TABLE SAW

DWE7492

Congratulations!

You have chosen a DEWALT tool. Years of experience, thorough product development and innovation make DEWALT one of the most reliable partners for professional power tool users.

Technical Data

		DWE7492
Voltage	V_{AC}	110
Motor power (input)	W	1650
Motor power (output)	W	800
No load speed	min^{-1}	4800
Blade diameter	mm	254
Blade bore	mm	16
Blade body thickness	mm	2.0
Splitter thickness	mm	2.2
Depth of cut at 90°	mm	79
Depth of cut at 45°	mm	57
Bevel angle	°	45–90
Maximum bevel angle	°	45–90
Mitre angle	°	30–90
Ripping capacity	mm	825
Overall dimensions	mm	680 x 650 x 330
Weight	kg	26.5

Definitions: Safety Guidelines

The definitions below describe the level of severity for each signal word. Please read the manual and pay attention to these symbols.



DANGER: Indicates an imminently hazardous situation which, if not avoided, **will** result in **death or serious injury**.



WARNING: Indicates a potentially hazardous situation which, if not avoided, **could** result in **death or serious injury**.



CAUTION: Indicates a potentially hazardous situation which, if not avoided, **may** result in **minor or moderate injury**.

NOTICE: Indicates a practice **not related to personal injury** which, if not avoided, **may** result in **property damage**.



Denotes risk of electric shock.



Denotes risk of fire.

General Power Tool Safety Warnings



WARNING: Read all safety warnings, instructions, illustrations and specifications provided with this power tool. Failure to follow all instructions listed below may result in electric shock, fire and/or serious injury.

SAVE ALL WARNINGS AND INSTRUCTIONS FOR FUTURE REFERENCE

The term “power tool” in the warnings refers to your mains-operated (corded) power tool or battery-operated (cordless) power tool.

1) Work area safety

- Keep work area clean and well lit.** Cluttered or dark areas invite accidents.
- Do not operate power tools in explosive atmospheres, such as in the presence of flammable liquids, gases or dust.** Power tools create sparks which may ignite the dust or fumes.
- Keep children and bystanders away while operating a power tool.** Distractions can cause you to lose control.

2) Electrical safety

- Power tool plugs must match the outlet. Never modify the plug in any way. Do not use any adapter plugs with earthed (grounded) power tools.** Unmodified plugs and matching outlets will reduce risk of electric shock.
- Avoid body contact with earthed or grounded surfaces such as pipes, radiators, ranges and refrigerators.** There is an increased risk of electric shock if your body is earthed or grounded.
- Do not expose power tools to rain or wet conditions.** Water entering a power tool will increase the risk of electric shock.
- Do not abuse the cord. Never use the cord for carrying, pulling or unplugging the power tool. Keep cord away from heat, oil, sharp edges or moving parts.** Damaged or entangled cords increase the risk of electric shock.
- When operating a power tool outdoors, use an extension cord suitable for outdoor use.** Use of a cord suitable for outdoor use reduces the risk of electric shock.
- If operating a power tool in a damp location is unavoidable, use a residual current device (RCD) protected supply.** Use of an RCD reduces the risk of electric shock.

3) Personal safety

- Stay alert, watch what you are doing and use common sense when operating a power tool. Do not use a power tool while you are tired or under the influence of drugs, alcohol or medication.** A moment

of inattention while operating power tools may result in serious personal injury.

- b) **Use personal protective equipment. Always wear eye protection.** Protective equipment such as dust mask, non-skid safety shoes, hard hat, or hearing protection used for appropriate conditions will reduce personal injuries.
- c) **Prevent unintentional starting. Ensure the switch is in the off position before connecting to power source and/or battery pack, picking up or carrying the tool.** Carrying power tools with your finger on the switch or energising power tools that have the switch on invites accidents.
- d) **Remove any adjusting key or wrench before turning the power tool on.** A wrench or a key left attached to a rotating part of the power tool may result in personal injury.
- e) **Do not overreach. Keep proper footing and balance at all times.** This enables better control of the power tool in unexpected situations.
- f) **Dress properly. Do not wear loose clothing or jewellery. Keep your hair, clothing and gloves away from moving parts.** Loose clothes, jewellery or long hair can be caught in moving parts.
- g) **If devices are provided for the connection of dust extraction and collection facilities, ensure these are connected and properly used.** Use of dust collection can reduce dust-related hazards.
- h) **Do not let familiarity gained from frequent use of tools allow you to become complacent and ignore tool safety principles.** A careless action can cause severe injury within a fraction of a second.

4) Power tool use and care

- a) **Do not force the power tool. Use the correct power tool for your application.** The correct power tool will do the job better and safer at the rate for which it was designed.
- b) **Do not use the power tool if the switch does not turn it on and off.** Any power tool that cannot be controlled with the switch is dangerous and must be repaired.
- c) **Disconnect the plug from the power source and/or remove the battery pack, if detachable, from the power tool before making any adjustments, changing accessories, or storing power tools.** Such preventive safety measures reduce the risk of starting the power tool accidentally.
- d) **Store idle power tools out of the reach of children and do not allow persons unfamiliar with the power tool or these instructions to operate the power tool.** Power tools are dangerous in the hands of untrained users.
- e) **Maintain power tools and accessories. Check for misalignment or binding of moving parts, breakage of parts and any other condition that may affect the power tool's operation. If damaged, have the power tool repaired before use.** Many accidents are caused by poorly maintained power tools.

- f) **Keep cutting tools sharp and clean.** Properly maintained cutting tools with sharp cutting edges are less likely to bind and are easier to control.
- g) **Use the power tool, accessories and tool bits etc., in accordance with these instructions taking into account the working conditions and the work to be performed.** Use of the power tool for operations different from those intended could result in a hazardous situation.
- h) **Keep handles and grasping surfaces dry, clean and free from oil and grease.** Slippery handles and grasping surfaces do not allow for safe handling and control of the tool in unexpected situations.

5) Service

- a) **Have your power tool serviced by a qualified repair person using only identical replacement parts.** This will ensure that the safety of the power tool is maintained.

Safety Instructions for Table Saws

1) Guarding Related Warnings

- a) **Keep guards in place. Guards must be in working order and be properly mounted.** A guard that is loose, damaged, or is not functioning correctly must be repaired or replaced.
- b) **Always use saw blade guard, riving knife and anti-kickback pawls for every through-cutting operation.** For through-cutting operations where the saw blade cuts completely through the thickness of the workpiece, the guard and other safety devices help reduce the risk of injury.
- c) **Immediately reattach the guarding system after completing an operation (such as rabbeting cuts) which requires removal of the guard, riving knife and/or anti-kickback device.** The guard, riving knife, and anti-kickback device help to reduce the risk of injury.
- d) **Make sure the saw blade is not contacting the guard, riving knife or the workpiece before the switch is turned on.** Inadvertent contact of these items with the saw blade could cause a hazardous condition.
- e) **Adjust the riving knife as described in this instruction manual.** Incorrect spacing, positioning and alignment can make the riving knife ineffective in reducing the likelihood of kickback.
- f) **For the riving knife and anti-kickback pawls to work, they must be engaged in the workpiece.** The riving knife and anti-kickback pawls are ineffective when cutting workpieces that are too short to be engaged with the riving knife and anti-kickback pawls. Under these conditions a kickback cannot be prevented by the riving knife and anti-kickback pawls.
- g) **Use the appropriate saw blade for the riving knife.** For the riving knife to function properly, the saw blade diameter must match the appropriate riving knife and the body of the saw blade must be thinner than the thickness of the riving knife and the cutting width of the saw blade must be wider than the thickness of the riving knife.

2) Cutting Procedures Warnings

- a)  **DANGER: Never place your fingers or hands in the vicinity or in line with the saw blade.** A moment of inattention or a slip could direct your hand towards the saw blade and result in serious personal injury.
- b) **Feed the workpiece into the saw blade or cutter only against the direction of rotation.** Feeding the workpiece in the same direction that the saw blade is rotating above the table may result in the workpiece, and your hand, being pulled into the saw blade.
- c) **Never use the mitre gauge to feed the workpiece when ripping and do not use the rip fence as a length stop when cross cutting with the mitre gauge.** Guiding the workpiece with the rip fence and the mitre gauge at the same time increases the likelihood of saw blade binding and kickback.
- d) **When ripping, always apply the workpiece feeding force between the fence and the saw blade. Use a push stick when the distance between the fence and the saw blade is less than 150 mm, and use a push block when this distance is less than 50 mm.** "Work helping" devices will keep your hand at a safe distance from the saw blade.
- e) **Use only the push stick provided by the manufacturer or constructed in accordance with the instructions.** This push stick provides sufficient distance of the hand from the saw blade.
- f) **Never use a damaged or cut push stick.** A damaged push stick may break causing your hand to slip into the saw blade.
- g) **Do not perform any operation "freehand". Always use either the rip fence or the mitre gauge to position and guide the workpiece.** "Freehand" means using your hands to support or guide the workpiece, in lieu of a rip fence or mitre gauge. Freehand sawing leads to misalignment, binding and kickback.
- h) **Never reach around or over a rotating saw blade.** Reaching for a workpiece may lead to accidental contact with the moving saw blade.
- i) **Provide auxiliary workpiece support to the rear and/or sides of the saw table for long and/or wide workpieces to keep them level.** A long and/or wide workpiece has a tendency to pivot on the table's edge, causing loss of control, saw blade binding and kickback.
- j) **Feed workpiece at an even pace. Do not bend or twist the workpiece. If jamming occurs, turn the tool off immediately, unplug the tool then clear the jam.** Jamming the saw blade by the workpiece can cause kickback or stall the motor.
- k) **Do not remove pieces of cut-off material while the saw is running.** The material may become trapped between the fence or inside the saw blade guard and the saw blade pulling your fingers into the saw blade. Turn the saw off and wait until the saw blade stops before removing material.

- l) **Use an auxiliary fence in contact with the table top when ripping workpieces less than 2 mm thick.** A thin workpiece may wedge under the rip fence and create a kickback.

3) Kickback Causes and Related Warnings

Kickback is a sudden reaction of the workpiece due to a pinched, jammed saw blade or misaligned line of cut in the workpiece with respect to the saw blade or when a part of the workpiece binds between the saw blade and the rip fence or other fixed object.

Most frequently during kickback, the workpiece is lifted from the table by the rear portion of the saw blade and is propelled towards the operator.

Kickback is the result of saw misuse and/or incorrect operating procedures or conditions and can be avoided by taking proper precautions as given below.

- a) **Never stand directly in line with the saw blade. Always position your body on the same side of the saw blade as the fence.** Kickback may propel the workpiece at high velocity towards anyone standing in front and in line with the saw blade.
- b) **Never reach over or in back of the saw blade to pull or to support the workpiece.** Accidental contact with the saw blade may occur or kickback may drag your fingers into the saw blade.
- c) **Never hold and press the workpiece that is being cut off against the rotating saw blade.** Pressing the workpiece being cut off against the saw blade will create a binding condition and kickback.
- d) **Align the fence to be parallel with the saw blade.** A misaligned fence will pinch the workpiece against the saw blade and create kickback.
- e) **Use a featherboard to guide the workpiece against the table and fence.** A featherboard helps to control the workpiece in the event of a kickback.
- f) **Support large panels to minimise the risk of saw blade pinching and kickback.** Large panels tend to sag under their own weight. Support(s) must be placed under all portions of the panel overhanging the table top.
- g) **Use extra caution when cutting a workpiece that is twisted, knotted, warped or does not have a straight edge to guide it with a mitre gauge or along the fence.** A warped, knotted, or twisted workpiece is unstable and causes misalignment of the kerf with the saw blade, binding and kickback.
- h) **Never cut more than one workpiece, stacked vertically or horizontally.** The saw blade could pick up one or more pieces and cause kickback.
- i) **When restarting the saw with the saw blade in the workpiece, centre the saw blade in the kerf so that the saw teeth are not engaged in the material.** If the saw blade binds, it may lift up the workpiece and cause kickback when the saw is restarted.

- j) **Keep saw blades clean, sharp, and with sufficient set. Never use warped saw blades or saw blades with cracked or broken teeth.** Sharp and properly set saw blades minimise binding, stalling and kickback.

4) Table Saw Operating Procedure Warnings

- a) **Turn off the table saw and disconnect from the power source when removing the table insert, changing the saw blade or making adjustments to the riving knife, anti-kickback pawls or saw blade guard, and when the machine is left unattended.** Precautionary measures will avoid accidents.
- b) **Never leave the table saw running unattended. Turn it off and don't leave the tool until it comes to a complete stop.** An unattended running saw is an uncontrolled hazard.
- c) **Locate the table saw in a well-lit and level area where you can maintain good footing and balance. It should be installed in an area that provides enough room to easily handle the size of your workpiece.** Cramped, dark areas, and uneven slippery floors invite accidents.
- d) **Frequently clean and remove sawdust from under the saw table and/or the dust collection device.** Accumulated sawdust is combustible and may self-ignite.
- e) **The table saw must be secured.** A table saw that is not properly secured may move or tip over.
- f) **Remove tools, wood scraps, etc. from the table before the table saw is turned on.** Distraction or a potential jam can be dangerous.
- g) **Always use saw blades with correct size and shape (diamond versus round) of arbour holes.** Saw blades that do not match the mounting hardware of the saw will run off-centre, causing loss of control.
- h) **Never use damaged or incorrect saw blade mounting means such as flanges, saw blade washers, bolts or nuts.** These mounting means were specially designed for your saw, for safe operation and optimum performance.
- i) **Never stand on the table saw, do not use it as a stepping stool.** Serious injury could occur if the tool is tipped or if the cutting tool is accidentally contacted.
- j) **Make sure that the saw blade is installed to rotate in the proper direction. Do not use grinding wheels, wire brushes, or abrasive wheels on a table saw.** Improper saw blade installation or use of accessories not recommended may cause serious injury.

Additional Safety Rules for Table Saws



WARNING: Cutting plastics, sap coated wood, and other materials may cause melted material to accumulate on the blade tips and the body of the saw blade, increasing the risk of blade overheating and binding while cutting.

- **Avoid awkward positions, where a sudden slip could cause a hand to move into a saw blade.**
- **Do not attempt to retrieve materials near the blade on the saw table while the blade is spinning.**

- **Never reach in back of, or around, the cutting tool with either hand to hold down the workpiece.**
- **Keep arms, hands and fingers away from the blade to prevent serious injury.**
- **Use a push stick that is appropriate to the application to push workpieces through the saw.** A push stick is a wooden or plastic stick, often homemade, that should be used whenever the size or shape of the workpiece would cause you to place your hands within 152 mm of the blade.
- **Use hold-downs, jigs, fixtures or feather boards to help guide and control the workpiece.** Accessories for use with your tool are available at extra cost from your local dealer or authorized service centre.
- **Do not perform ripping, crosscutting or any other operation freehand.**
- **Never reach around or over saw blade while the blade is spinning.**
- **Stability.** Make sure the table saw is firmly mounted to a secure surface before use and does not move.
- **The table saw should only be set up on a level and stable surface.** The work area should be free from obstructions and trip hazards. No materials or tools should be leaned against the saw.
- **Never cut metals, cement board or masonry.** Certain man-made materials have special instructions for cutting on table saws. Follow the manufacturer's recommendations at all times. Damage to the saw and personal injury may result.
- **Do not install a diamond masonry blade and attempt to use the table saw as a wet saw.**
- **The proper throat plate must be locked in place at all times to reduce the risk of a thrown workpiece and possible injury.**
- **Wear gloves when handling saw blades.**
- **Use the correct saw blade for the intended operation.** The blade must rotate toward the front of the saw. Always tighten the blade arbor nut securely. Before use, inspect the blade for cracks or missing teeth. Do not use a damaged or dull blade.
- **Never attempt to free a stalled saw blade without first turning the machine off and disconnect tool from power source.** If a workpiece or cut-off piece becomes trapped inside the blade guard assembly, turn saw off and wait for blade to stop before lifting the blade guard assembly and removing the piece.
- **Never start the machine with the workpiece against the blade to reduce the risk of a thrown workpiece and personal injury.**
- **Do not have any part of your body in line with the blade.** Personal injury may occur. Stand to either side of the blade.
- **Never perform layout, assembly or set-up work on the table/work area when the machine is running.** A sudden slip could cause a hand to move into the blade. Severe injury can result.

- **Never perform any adjustments while the saw is running such as fence repositioning or removal, bevel lock adjustment, or blade height adjustment.**
- **Clean the table/work area before leaving the machine.**
Lock the switch in the "OFF" position and disconnect tool from power source to prevent unauthorized use.
- **Always lock the fence and bevel adjustment before cutting.**
- **Avoid overheating the saw blade tips.** Keep material moving and parallel with the fence. Do not force work into the blade.
- **If cutting plastic materials, avoid melting the plastic.**
- **Do not leave a long board (or other workpiece) unsupported so the spring of the board causes it to shift on the table resulting in loss of control and possible injury.** Provide proper support for the workpiece, based on its size and the type of operation to be performed. Hold the work firmly against the fence and down against the table surface.
- **If this saw makes an unfamiliar noise or if it vibrates excessively, cease operating immediately, turn unit off and disconnect tool from power source until the problem has been located and corrected.** Contact a DEWALT factory service centre, a DEWALT authorized service centre or other qualified service personnel if the problem can not be found.
- **Do not operate this machine until it is completely assembled and installed according to the instructions.** A machine incorrectly assembled can cause serious injury.
- **Never attempt to cut a stack of loose pieces of material which could cause loss of control or kickback.** Support all materials securely.

Saw Blades



WARNING: to minimise the risk of kickback and to ensure proper cutting, the splitter and riving knife must be the proper thickness for the blade used. If a different blade is used, check the blade body (plate) thickness and the blade kerf (cutting) width marked on the blade or on the blade packaging. The splitter and riving knife thickness must be greater than the body thickness and less than the kerf width.

- Do not use saw blades that do not conform to the dimensions stated in the **Technical Data**. Do not use any spacers to make a blade fit onto the spindle. Use only the blades specified in this manual, complying with EN847-1, if intended for wood and similar materials.
- Consider applying specially designed noise-reduction blades.
- Do not use high steel (HS) saw blades.
- Do not use cracked or damaged saw blades.
- Ensure that the chosen saw blade is suitable for the material to be cut.
- Always wear gloves for handling saw blades and rough material. Saw blades should be carried in a holder wherever practicable.

Residual risks

The following risks are inherent to the use of saws:

- *injuries caused by touching the rotating parts*
- In spite of the application of the relevant safety regulations and the implementation of safety devices, certain residual risks cannot be avoided. These are:
- *Impairment of hearing.*
 - *Risk of accidents caused by the uncovered parts of the rotating saw blade.*
 - *Risk of injury when changing the saw blade with unprotected hands.*
 - *Risk of squeezing fingers when opening the guards.*
 - *Health hazards caused by breathing dust developed when sawing wood, especially oak, beech and MDF.*

The following factors are of influence to noise production:

- *the material to be cut*
- *the type of saw blade*
- *the feed force*
- *machine maintenance*

The following factors are of influence to dust exposure:

- *worn saw blade*
- *dust extractor with air velocity less than 20 m/s*
- *workpiece not exactly guided*

Electrical Safety

The electric motor has been designed for one voltage only. Always check that the power supply corresponds to the voltage on the rating plate.



Your DEWALT tool is double insulated in accordance with IEC60745; therefore no earth wire is required.



WARNING: 220-240V units have to be operated via a fail-safe isolating transformer with an earth screen between the primary and secondary winding.

If the supply cord is damaged, it must be replaced only by DEWALT or an authorised service organisation.

NOTE: This device is intended for the connection to a power supply system with maximum permissible system impedance Z_{max} of 0.28 Ω at the interface point (power service box) of user's supply. The user has to ensure that this device is connected only to a power system which fulfills the requirement above. If necessary, the user can ask the public power supply company for the system impedance at the interface point.

Using an Extension Cable

If an extension cable is required, use an approved 3-core extension cable suitable for the power input of this tool (see **Technical Data**). The minimum conductor size is 1.5 mm²; the maximum length is 30 m.

When using a cable reel, always unwind the cable completely.

Package Contents

The package contains:

- 1 Partly assembled machine
- 1 Rip fence
- 1 Mitre gauge
- 1 Upper blade guard assembly
- 1 Throat plate
- 2 Blade wrenches
- 1 Splitter wrench
- 1 Push Stick
- 1 Dust extraction adapter
- 1 Instruction manual
- Check for damage to the tool, parts or accessories which may have occurred during transport.
- Take the time to thoroughly read and understand this manual prior to operation.

Markings on Tool

The following pictograms are shown on the tool:



Read instruction manual before use.



Wear ear protection.



Wear eye protection.



Wear respiratory protection.



Keep hands away from cutting area and the blade.



splitter thickness



Saw blade body thickness and kerf width



Saw blade diameter



Lock/unlock cover at the main switch.



Unplug saw before changing blade



Protect the supply cord/plug against humidity and sharp edges of saw blade

Date Code Position (Fig. A)

The Date Code **51**, which also includes the year of manufacture, is printed into the housing.

Example:

2019 XX XX
Year of Manufacture

Description (Fig. A, B)



WARNING: Never modify the power tool or any part of it. Damage or personal injury could result.

- 1 Table
- 2 Blade (Sawblade not included for Taiwan area)
- 3 Rip scale indicator
- 4 Fine adjust knob
- 5 Rail lock lever
- 6 Blade height adjustment wheel
- 7 Bevel lock lever
- 8 ON/OFF switch
- 9 Mounting holes
- 10 Mitre gauge
- 11 Blade guard assembly
- 13 Splitter
- 14 Dust exhaust port
- 15 Guard dust exhaust port
- 16 Throat plate
- 17 Rip fence
- 18 Rip fence latch
- 19 Work support/narrow rip fence (shown in stored position)
- 20 Blade wrenches
- 21 Push stick (shown in stored position)
- 50 Carrying handles
- 53 Splitter Wrench
- 54 Splitter screw
- 55 Moutain Block
- 56 Splitter Plate
- 57 Anti kickback assembly
- 58 Stem
- 59 Anti kickback mounting slots

Intended Use

DWE7492 table saw is designed for professional ripping, cross-cutting, mitreing and bevelling with various materials as wood, wood composite materials and plastics.

DO NOT use under wet conditions or in the presence of flammable liquids or gases.

DO NOT use for cutting metal, cement board, or masonry.

DO NOT use shaping cutter heads on this saw.

DO NOT perform tapered cuts without a tapered jig accessory.

DO NOT use the saw for plunge or cove cutting.

These table saws are professional power tools.

DO NOT let children come into contact with the tool. Supervision is required when inexperienced operators use this tool.

- **Young children and the infirm.** This appliance is not intended for use by young children or infirm persons without supervision. This product is not intended for use by persons (including children) suffering from diminished physical, sensory or mental abilities; lack of experience, knowledge or skills unless they are supervised by a person responsible for their safety. Children should never be left alone with this product.

ASSEMBLY

- ⚠ **WARNING:** To reduce the risk of serious personal injury, turn tool off and disconnect tool from power source before making any adjustments or removing/installing attachments or accessories. An accidental start-up can cause injury.

Unpacking

- Remove the saw from the packaging material carefully.
- The machine is fully assembled except for the rip fence, blade guard assembly, mitre gauge, blade wrenches, and dust extraction reducer port.
- Finalize the assembly following the instructions as described below.

- ⚠ **WARNING:** Always keep the push stick in its place when not in use.

Mounting the Saw Blade (Fig. A, C)

- ⚠ **WARNING:** To reduce the risk of injury, turn unit off and disconnect machine from power source before installing and removing accessories, before adjusting or changing set-ups or when making repairs. An accidental start-up can cause injury.

- ⚠ **WARNING:** When mounting the saw blade, wear protective gloves. The teeth of the saw blades are very sharp and can be dangerous.

- ⚠ **WARNING:** The saw blade **MUST** be replaced as described in this section. **ONLY** use saw blades as specified under **Technical Data**. We suggest DT4226. **NEVER** fit other saw blades.

- ⚠ **WARNING:** Do not touch the saw blade after working before it has cooled. The saw blade becomes very hot while working.

NOTE: This tool has blade installed from factory.

1. Raise the saw blade arbor to its maximum height by turning the blade height adjustment wheel **6** clockwise.
2. Remove the throat plate **16**. Refer to **Mounting the Throat Plate**.
3. Using wrenches **20**, loosen and remove the arbor nut **22** and flange **24** from the saw arbor by turning anti-clockwise.
4. Place the saw blade on to the spindle **23** making sure the teeth of the blade **2** point down at the front of the table. Assemble the washers and arbor nut to the spindle and

tighten arbor nut **22** as far as possible by hand, making sure that the saw blade is against the inner washer and the outer flange **24** is against the blade. Ensure the largest diameter of the flange is against the blade. Ensure the spindle and washers are free from dust and debris.

5. To keep the spindle from rotating when tightening the arbor nut, use the open end of the blade wrench **20** to secure the spindle.
6. Using the arbor wrench, tighten the arbor nut **22** by turning it clockwise.
7. Replace the throat plate.

- ⚠ **WARNING:** Always check the rip fence pointer and the blade guard assembly after having changed the blade.

Mounting the Blade Guard Assembly (Fig. A, D)

- ⚠ **WARNING:** Use the guard assembly for all through cutting.

1. Set the saw blade **2** to the maximum cutting depth. Set it at 45° and lock it.
2. Dismount the splitter screws **54** and splitter plate **56**.
3. Put the splitter **13** on mounting block **55** and add the splitter plate **56**.
4. Lock them by tightening the two splitter screws **54**.

- ⚠ **WARNING:** Before connecting the table saw to the power source or operating the saw, always inspect the blade guard assembly for proper alignment and clearance with saw blade. Check alignment after each change of bevel angle.

- ⚠ **WARNING:** To reduce the risk of serious personal injury, DO NOT operate saw if blade assembly is not securely clamped in place.

When properly aligned, the splitter **13** will be in line with the blade at both table top level, and at the top of the blade. Using a straight edge, ensure that the blade **2** is aligned with the splitter **13**. With power disconnected, operate the blade tilt and height adjustments through the extremes of travel and insure the blade guard assembly clears the blade in all operations. Refer to **Aligning Guard Assembly/Splitter to Blade**.

- ⚠ **WARNING:** Correct mounting and alignment of the blade guard assembly is essential to safe operation!

To Remove the Blade Guard Assembly (Fig. D)

1. Dismount the splitter screws **54**.
2. Remove the splitter plate **56** and blade guard assembly **11**.

Mounting the Throat Plate (Fig. E)

1. Align the throat plate **16** as shown in Figure E, and insert the tabs on the back of the throat plate into the holes on the back of the table opening.
2. Rotate cam counterclockwise until the front of throat plate drops into place. Secure by rotating cam lock knob **40** clockwise 1/4 turn (when cam lock is under the table holding the throat plate in place).

- The throat plate includes four adjustments **25** which raise or lower the throat plate. When properly adjusted, the front of the throat plate should be flush or slightly below the surface of the table top and secured in place. The rear of the throat plate should be flush or slightly above the table top.

 **WARNING:** Never use the machine without the throat plate. Immediately replace the throat plate when worn or damaged.

Mounting the Anti-Kickback Assembly

(Fig. U)

 **WARNING:** To reduce the risk of serious personal injury, the anti-kickback assembly must be in place for all possible cuts.

- Remove the anti-kickback assembly **57** from the storage position. Refer to Storage.
- Locate the anti-kickback mounting slot **59** at the top of the splitter **13**.
- Align the stem **58** with the mounting slot. Depress the stem and push down on the anti-kickback assembly **57** until it snaps and locks into place.

NOTE: Pull on the anti-kickback assembly to ensure it has locked into place.

- To remove the anti-kickback assembly, depress the stem and pull up and out of the mounting slot. With power disconnected, operate the blade tilt and height adjustments through the extremes of travel and ensure the blade guard assembly clears the blade in all operations and that the antikickback assembly is functioning.

Fitting the Rip Fence (Fig. F)

The rip fence can be installed in two positions on the right (Position 1 for 0 mm to 62 cm ripping, and Position 2 for 20.3 cm to 82.5 cm ripping) and one position on the left of your table saw.

- Unlock the rip fence latches **18**.
- Holding the fence at an angle, align the locator pins (front and back) **29** on the fence rails with the fence head slots **30**.
- Slide the head slots onto the pins and rotate the fence down until it rests on the rails.
- Lock the fence in place by closing the front and back latches **18** onto the rails.

Bench Mounting (Fig. A)

 **CAUTION:** To reduce the risk of personal injury, make sure table saw is firmly mounted to a stable surface before use.

 **CAUTION:** Ensure that the surface is stable enough that large pieces of material will not cause it to tip over during use.

The table saw must be mounted firmly. Four holes **9** are provided in the tool's base for mounting. We strongly recommend that these holes be used to anchor the table saw to your workbench or other stationary rigid frame.

- Centre the saw on a square piece of 12.7 mm plywood.
- Mark the positions of the two rear mounting holes (spaced 220 mm apart) in the frame of the saw with a pencil. Then measure forward 498.5 mm for the two front holes spaced 230 mm apart.
- Remove the saw and drill 9 mm holes in the places you have just marked.
- Position the saw over the four holes you drilled in the plywood and insert four 8 mm machine screws FROM THE BOTTOM. Install washers and 8 mm nuts on the top. Tighten securely.
- In order to prevent the screw heads from marring the surface to which you clamp the saw, attach two strips of scrap wood to the bottom of the plywood base. These strips can be attached with wood screws installed from the top side as long as they don't protrude through the bottom of the strip.
- Use a "C" clamp to secure the plywood base to your workbench whenever you use the saw.

ADJUSTMENTS

Blade Adjustment (Fig. G)

Blade Alignment (Parallel to Mitre Slot)

 **WARNING:** Cut Hazard. Check the blade at 0° and 45° to make sure blade does not hit the throat plate, causing personal injury.

If the blade appears to be out of alignment with the mitre slot on the table top, it will require calibration for alignment. To realign the blade and mitre slot, use the following procedure:

 **WARNING:** To reduce the risk of injury, turn unit off and disconnect machine from power source before installing and removing accessories, before adjusting or changing set-ups or when making repairs. An accidental start-up can cause injury.

- Using a 5 mm hex wrench, loosen rear pivot bracket fasteners **32**, located on the underside of the table, just enough to allow the bracket to move side-to-side.
- Adjust the bracket until the blade is parallel to the mitre gauge slot.
- Tighten the rear pivot bracket fasteners to 12.5–13.6 Nm (110–120 in-lbs).

Blade height adjustment (Fig. A)

The blade can be raised and lowered by turning the blade height adjustment wheel **6**.

Make sure the top three teeth of the blade are just breaking through the upper surface of the workpiece when sawing. This will ensure that the maximum number of teeth are removing material at any given time, thus giving optimum performance.

Aligning Guard Assembly/Splitter to Blade (Fig. A, H)

1. Remove the throat plate. Refer to **Remove Throat Plate**.
2. Raise the blade to full depth of cut and 0° bevel angle.
3. Locate the three small set screws **39** adjacent to the guard assembly lock shaft **38**. These screws will be used to adjust the guard assembly position.
4. Lay a straight edge on the table against two blade tips. The splitter **13** should not touch the straight edge. If needed, loosen the two larger lock screws **41**.
5. Adjust the small set screws **39** to move the splitter according to the position noted in step 4. Lay the straight edge on the opposite side of the blade and repeat adjustments as needed.
6. Lightly tighten the two larger lock screws **41**.
7. Place a square flat against the splitter to the verify splitter is vertical and in-line with the blade.
8. If needed, use the set screws to bring the splitter vertical with the square.
9. Repeat steps 4 and 5 to verify position of splitter.
10. Fully tighten the two larger lock screws **41**.
11. Re-install and lock the throat plate **16**.

Parallel Adjustment (Fig. A, I, J, O)



WARNING: A misaligned fence, not parallel to the blade, increases the risk of kickback!

For optimum performance, the blade must be parallel to the rip fence. This adjustment has been made at the factory. To re-adjust:

Position 1 Fence Alignment

1. Install the fence in position 1 and unlock the rail lock lever **5**. Locate both locator pins **29** that support the fence on the front and rear rails.
2. Loosen the rear locator pin screw and adjust the alignment of the fence in the groove until the fence face is parallel to the blade. Make sure you measure from the fence face to the front and back of the blade to ensure alignment.
3. Tighten the locator screw and repeat on the left side of the blade.
4. Check rip scale pointer adjustment (Fig. J).

Position 2 Fence Alignment

1. To align position 2 fence locator pins **29**, ensure position 1 pins have been aligned, refer to **Position 1 Fence Alignment**.
2. Loosen the position 2 pins, then using the blade wrench holes as a guide for positioning, align the pins (Fig. O).
3. Tighten the locator pins (front and rear).

Adjusting the Rip Scale (Fig. A, J)

1. Unlock the rail lock lever **5**.
2. Set the blade at 0° bevel and move the fence in until it touches the blade.
3. Lock the rail lock lever.

4. Loosen the rip scale indicator screws **31** and set the rip scale indicator to read zero (0). Retighten the rip scale indicator screws. The yellow rip scale (top) reads correctly only when the fence is mounted on the right side of the blade and is in position 1 (for zero to 62 cm ripping) not the 82.5 cm rip position. The white scale (bottom) reads correctly only when the fence is mounted on the right side of the blade and in position 2 (for 20.3 cm to 82.5 cm ripping).

The rip scale reads correctly only when the fence is mounted to the right of the blade.

Rail Lock Adjustment (Fig. A, K)

The rail lock has been factory-set. If you need to re-adjust, proceed as follows:

1. Lock the rail lock lever **5**.
2. On the underside of the saw, loosen the jam nut **33**.
3. Tighten the hex rod **34** until the spring on the locking system is compressed creating the desired tension on the rail lock lever. Retighten the jam nut against the hex rod.
4. Flip the saw over and check that the fence does not move when the lock lever is engaged. If the fence is still loose, tighten the spring further.

Bevel Stop and Pointer Adjustment (Fig. L)

1. Raise the blade fully by rotating the blade height adjustment wheel **6** clockwise until it stops.
2. Unlock the bevel lock lever **7** by pushing it up and to the right. Loosen the bevel stop screw **36**.
3. Place a square flat against the table top and against the blade between teeth. Ensure the bevel lock lever is in its unlocked, or up position.
4. Using the bevel lock lever, adjust the bevel angle until the blade is flat against the square.
5. Tighten the bevel lock lever by pushing it down.
6. Turn the bevel stop cam **35** until it firmly contacts the bearing block. Tighten the bevel stop screw **36**.
7. Check the bevel angle scale. If the pointer does not read 0°, loosen pointer screw **37** and move the pointer so it reads correctly. Retighten the pointer screw.
8. Repeat at 45°, but do not adjust pointer.

Mitre Gauge Adjustment (Fig. A)

To adjust mitre gauge **10** loosen knob, set to desired angle and tighten knob.

Body and Hand Position

Proper positioning of your body and hands when operating the table saw will make cutting easier, more accurate and safer.



WARNING:

- Never place your hands near the cutting area.
- Place your hands no closer than 150 mm from the blade.
- Do not cross your hands.

- Keep both feet firmly on the floor and maintain proper balance.

Prior to Operation



WARNING:

- Install the appropriate saw blade. Do not use excessively worn blades. The maximum rotation speed of the tool must not exceed that of the saw blade.
- Do not attempt to cut excessively small pieces.
- Allow the blade to cut freely. Do not force.
- Allow the motor to reach full speed before cutting.

OPERATION

Instructions for Use



WARNING: Always observe the safety instructions and applicable regulations.



WARNING: To reduce the risk of serious personal injury, turn tool off and disconnect tool from power source before making any adjustments or removing/installing attachments or accessories. An accidental start-up can cause injury.

The attention of UK users is drawn to the “woodworking machines regulations 1974” and any subsequent amendments.

Ensure the machine is placed to satisfy your ergonomic conditions in terms of table height and stability. The machine site shall be chosen so that the operator has a good overview and enough free surrounding space around the machine that allows handling of the workpiece without any restrictions.

To reduce effects of increased vibration, make sure the environment is not too cold, the machine and accessory are well maintained and the workpiece size is suitable for this machine.



WARNING:

- Ensure the machine is placed to satisfy ergonomic conditions in terms of table height and stability. The machine site shall be chosen so that the operator has a good overview and enough free surrounding space around the machine that allow handling of the workpiece without any restrictions.
- Install the appropriate saw blade. Do not use excessively worn blades. The maximum rotation speed of the tool must not exceed that of the saw blade.
- Do not attempt to cut excessively small pieces.
- Allow the blade to cut freely. Do not force.
- Allow the motor to reach full speed before cutting.
- Make sure all locking knobs and clamp handles are tight.
- Never place either hand in the blade area when the saw is connected to the electrical power source.
- Never use your saw for freehand cuts!
- Do not saw warped, bowed or cupped workpieces. There must be at least one straight, smooth side to go against the rip fence or mitre fence.
- Always support long workpieces to prevent kickback.

- Do not remove any cut-offs from the blade area while the blade is running.

Switching On and Off (Fig. M)

The on/off switch **8** of your saw bench offers multiple advantages:

- No-volt release function: should the power be shut off for any reason, the switch has to be deliberately reactivated.
- To switch the machine on, press the green start button.
- To switch the machine off, press the red stop button.

Lock Off Feature Instructions

A cover above the switch folds down for insertion of a padlock to lock the saw off. A padlock with a maximum diameter of 6.35 mm and minimum clearance of 76.2 mm is recommended.

Rip Fence Operation (Fig. N–P)

Rail lock lever

The rail lock lever **5** locks the fence in place preventing movement during cutting. To lock the rail lever, push it down and toward the rear of the saw. To unlock, pull it up and toward the front of the saw.

NOTE: When ripping, always lock the rail lock lever.

Work Support Extension / Narrow Ripping Fence

Your table saw is equipped with a work support extension to support work that extends beyond the saw table.

To use the narrow ripping fence in the work support position, rotate it from its stored position as shown in Figure O, and slide the pins into the lower sets of slots **27** on both ends of the fence.

To use the narrow ripping fence in the narrow ripping position, snap the pins into the upper sets of slots **28** on both ends of the fence. This feature will allow 51 mm of extra clearance to the blade. Refer to Figure P.

NOTE: Retract the work support extension or adjust to narrow rip fence position whenever working over the table.

NOTE: When using the narrow ripping fence, subtract 51 mm from the indicated rip scale reading.

Fine Adjustment Knob

The fine adjustment knob **4** allows smaller adjustments when setting the fence. Before adjusting, be sure the rail lock lever is in its up or unlocked, position.

Rip Scale Pointer

The rip scale pointer will need to be adjusted for proper performance of the rip fence if the user switches between thick and thin kerf blades. The rip scale pointer only reads correctly when the fence is installed in position 1 or 2 to the right side of the blade. When using the narrow ripping fence for narrow ripping (not in work support position), subtract 51 mm from the indicated rip scale reading. See **Adjusting the Rip Scale** under **Adjustments**.

Guard Operating Feature (Fig. V)



WARNING: To reduce the risk of injury, turn unit off and disconnect machine from power source before installing and removing accessories, before adjusting or changing set-ups or when making repairs. An accidental start-up can cause injury.

1. The clear side guard(s) will lock in place when in the raised position.
2. This feature increases visibility when measuring the blade to fence distance.
3. Push down on guard(s) and they will release to the operating position.

NOTE: Pull on the anti-kickback assembly to ensure it is locked in place. ALWAYS make sure both guards are in the down position in contact with the table before operating.

BASIC SAW CUTS

Through-Cutting Operations



WARNING: Use blade guard assembly for all through-cutting operations.

Ripping (Fig. A, B, Q, R)



WARNING: Sharp edges.

1. Set the blade to 0°.
2. Install the rip fence and lock the rip fence latch **18** (Fig. A).
3. Raise the blade until it is about 3 mm higher than the top of the workpiece. Adjust the height of the upper blade guard as necessary.
4. Adjust the position of the fence and lock the rail lock lever **5**, refer to **Rip Fence Operation**.
5. Hold the workpiece flat on the table and against the fence. Keep the workpiece away from the blade.
6. Keep both hands away from the path of the blade (Fig. Q).
7. Switch the machine on and allow the blade to reach full speed.
8. Slowly feed the workpiece underneath the guard, keeping it firmly pressed against the rip fence. Allow the teeth to cut, and do not force the workpiece through the blade. The blade speed should be kept constant.
9. Always use a push stick **21** when working close to the blade (Fig. R).
10. After completing the cut, switch the machine off, allow the blade to stop and remove the workpiece.



WARNING:

- Never push or hold the "free" or cut-off-side of the workpiece.
- Do not cut excessively small workpieces.
- Always use a push stick when ripping small workpieces.

Bevel Cuts (Fig. A)

1. To set the required bevel angle, rotate the bevel lock lever **7** by pushing it up and to the right.

2. To set to desired angle, rotate the lever by pushing it down and to the left to lock in place.
3. Proceed as for ripping.

Cross-Cutting and Bevel Crosscutting (Fig. Q)

1. Remove the rip fence and install the mitre gauge in the desired slot.
2. Lock the mitre gauge at 0°.
3. Proceed as for ripping.

Mitre Cuts (Fig. A)

1. Set the mitre gauge **10** to the required angle.

NOTE: Always hold the workpiece tightly against the face of the mitre gauge.

2. Proceed as for ripping.

Compound Mitre

This cut is a combination of a mitre and a bevel cut. Set the bevel to the angle required and proceed as for a cross-cut mitre.

Support for Long Pieces

- Always support long pieces.
- Support long workpieces using any convenient means such as saw-horses or similar devices to keep the ends from dropping.



Dust extraction (Fig. A, AA)

The machine is provided with a dust exhaust port **14** at the rear of the machine suitable for use with dust extraction equipment featuring 57/65 mm nozzles. Supplied with the machine is a reducer port for use of dust extraction nozzles of 34–40 mm diameter.

Supplied with the machine is a reducer port for use with the DEWALT AirLock system (DWV9000-XJ).

The blade guard assembly also features a dust exhaust port for 35mm nozzles or direct attachment to the DEWALT AirLock (DWV9000-XJ).

Dust from materials such as lead-containing coatings and some wood types, can be harmful to one's health. Breathing-in the dust can cause allergic reactions and/or lead to respiratory infections of the user or bystanders.

Certain dust, such as oak or beech dust, is considered carcinogenic, especially in connection with wood-treatment additives.

Observe the relevant regulations in your country for the materials to be worked.

The vacuum cleaner must be suitable for the material being worked.

When vacuuming dry dust that is especially detrimental to health or carcinogenic, use dust class M vacuum cleaner.

The blade guard assembly also features a dust exhaust port for 35 mm nozzles (M class vacuum).

- During all operations, connect a dust extraction device designed in accordance with the relevant regulations regarding dust emission.
- Ensure that the dust extraction hose in use is suitable for the application and material being cut. Ensure proper hose management.
- Be aware that man-made materials such as chipboard or MDF produce more dust particles during cutting than natural timber.

Storage (Fig. B, X–Z)

Store the machine in a safe manner when not being used. The storage location must be dry and lockable. This prevents the machine from storage damage, and from being operated by untrained persons.

1. Attach push stick **21** to fence.
2. Remove blade guard assembly. See **To Remove Blade Guard Assembly**. Slide blade guard assembly **11** into holder as shown, then turn lock knob 1/4 to lock in place. Refer to Figure X.
3. Slide blade wrenches **20** into pocket until yellow button aligns with hole to secure in place, refer to Figure B.
4. Insert guide bar of mitre gauge into pocket until it bottoms out.
5. Wrap cord in this location **43**. Refer to Figure Z.
6. To store fence, snap work support in stored position. Remove fence from rails. Reattach fence upside down on left side of saw, refer to Figure Y. DO NOT hook locator slots on left side fence locator screws. These screws will align with clearance pocket on fence as shown. Close the rip fence latches **18** to secure. Storage (Fig. B, X–Z)

Storage (Fig. BB)

1. Depress the stem on the anti-kickback assembly **57** to allow the assembly to slide from the riving knife slot.
2. Position anti-kickback assembly into the storage hole as shown. While depressing stem **58** slide the anti-kickback assembly across the storage bracket **60** and release pin to lock into place.

Transporting (Fig. A, B)

Before transportation following has to be done:

- Wrap cord
- Turn the blade height adjustment wheel **6** in anticlockwise direction until the teeth of the saw blade are positioned below the saw table. Lock the bevel lock lever **7**.
- Slide the fence rails completely inward and fix it by rail lock lever **5**.
- Always carry the machine using the designated handles **50**, refer to Figures A and B.

 **WARNING:** Always transport the machine with the upper blade guard fitted.

MAINTENANCE

Your DEWALT power tool has been designed to operate over a long period of time with a minimum of maintenance. Continuous satisfactory operation depends upon proper tool care and regular cleaning.

 **WARNING:** To reduce the risk of serious personal injury, turn tool off and disconnect tool from power source before making any adjustments or removing/installing attachments or accessories. An accidental start-up can cause injury.



Lubrication (Fig. T)

The motor and bearings require no additional lubrication. If raising and lowering the blade becomes difficult, clean and grease the height adjustment screws:

1. Unplug the saw from power source.
2. Turn the saw on its side.
3. Clean and lubricate the height adjustment screw threads **42** on the underside of this saw as shown in Figure T. Use general purpose grease.





Cleaning (Fig. A, S)

 **WARNING:** To reduce the risk of serious personal injury, turn unit off and disconnect machine from power source before cleaning. An accidental start-up can cause injury.

 **WARNING:** Blow dirt and dust out of the main housing with dry air as often as dirt is seen collecting in and around the air vents. Wear approved eye protection and approved dust mask when performing this procedure.

 **WARNING:** Never use solvents or other harsh chemicals for cleaning the non-metallic parts of the tool. These chemicals may weaken the materials used in these parts. Use a cloth dampened only with water and mild soap. Never let any liquid get inside the tool; never immerse any part of the tool into a liquid.

 **WARNING:** To reduce the risk of injury, regularly clean the table top.

 **WARNING:** To reduce the risk of injury, regularly clean the dust collection system.

The blade guard assembly **11** and throat plate must be placed in position before operating the saw.

Before use, carefully inspect upper and lower blade guards as well as the dust extraction tube to determine that it will operate properly. Ensure that chips, dust or work piece particles cannot lead to blockage of one of the functions.

In case workpiece fragments are jammed between saw blade and guards, disconnect the machine from the power supply and follow the instructions given in section **Mounting the saw blade**. Remove the jammed parts and reassemble the saw blade.

Keep the ventilation slots clear and regularly clean the housing with a soft cloth.

Regularly clean the dust collection system:

1. Unplug the saw.
2. Turn the saw on its side, so the bottom, open part of the unit is accessible.
3. Open the dust access door **44** shown in Figure 5 loosening the two screws and then by pressing the side clips **45** toward each other. Clean out the excess dust, and re-secure by pushing the side clips completely into place then tightening the lock screws.

Optional Accessories



WARNING: *Since accessories, other than those offered by DEWALT, have not been tested with this product, use of such accessories with this tool could be hazardous.*

To reduce the risk of injury, only DEWALT recommended accessories should be used with this product.

Consult your dealer for further information on the appropriate accessories.

Replace blade guard when worn. Contact your local DEWALT service centre for details on a blade guard replacement.

SAW BLADES: ALWAYS USE 254 mm noise reduced saw blades with 16 mm arbour holes. Blade speed rating must be at least 5000 RPM. Never use a smaller diameter blade. It will not be guarded properly.

BLADE DESCRIPTIONS

APPLICATION	DIAMETER	TEETH
Construction Saw Blades (<i>fast rip</i>)		
General Purpose	254 mm	24
Fine Crosscuts	254 mm	40
Woodworking Saw Blades (<i>provide smooth, clean cuts</i>)		
Fine crosscuts	254 mm	60

Consult your dealer for further information on the appropriate accessories.

- DWE74911 Rolling Table Saw Stand
- DWE74912 Scissor Leg Stand

Protecting the Environment



Separate collection. Products and batteries marked with this symbol must not be disposed of with normal household waste.

Products and batteries contain materials that can be recovered or recycled reducing the demand for raw materials. Please recycle electrical products and batteries according to local provisions. Further information is available at www.2helpU.com.

After Service and Repair

- DEWALT service centers are staffed with trained personnel to provide customers with efficient and reliable product service.
- We do not take any responsibility when you have repaired in unauthorized service center. You can refer to the leaflet of CONTACT CENTER LOCATOR in product package and contact us through hotline, website or social media to find the nearest DEWALT service center around you.

桌上型圓鋸機

DWE7492

恭喜!

感謝您選購 DeWALT 工具。憑藉多年的經驗、完善的產品開發與創新，DeWALT 已成為專業電動工具使用者最可靠的合作夥伴之一。請注意！各地區上市產品/配件不盡相同，請依台灣繁體中文說明書的內容為主。

技術資料

		DWE7492
電壓	伏特 _{交流}	110
電機功率(輸入)	瓦特	1650
電機功率(輸出)	瓦特	800
空載轉速	轉/分	4800
鋸片直徑	公釐	254
鋸片孔徑	公釐	16
鋸片厚度	公釐	2.0
分料刀厚度	公釐	2.2
90° 時的切割深度	公釐	79
45° 時的切割深度	公釐	57
斜面角度	°	45-90
最大斜面角度	°	45-90
斜切角度	°	30-90
縱割能力	公釐	825
整體尺寸	公釐	680 x 650 x 330
重量	kg	26.5

定義:安全指南

以下定義描述了每一個詞彙的嚴重程度。請閱讀本手冊並注意這些符號。

 **危險:**表示緊急危險狀況,若未能避免,將導致**死亡**或**嚴重傷害**。

 **警告:**表示潛在危險情況,若未能避免,可能導致**死亡**或**嚴重傷害**。

 **小心:**表示潛在危險情況,若未能避免,可能導致**輕微**或**中度傷害**。

注意:表示一種**非人身傷害**的行為,若未能避免,可能導致**財產損失**。

 表示**觸電危險**。

 表示**火災危險**。

電動工具一般安全警告

 **警告!**請閱讀安全警告及所有指示。不遵循下列的這些警告和指示可能會導致觸電、火災及/或嚴重傷害。

請保存所有警告與指示以備將來查閱。

以下列示所有警告中的術語「電動工具」是指電源驅動(插電)電動工具或電池驅動(充電)電動工具。

1) 工作場地安全

- 請保持工作場地清潔明亮。混亂或黑暗的場地會引發事故。
- 請勿在易爆環境,如有易燃液體、氣體或粉塵的環境中操作電動工具。電動工具產生的火花可能會引燃粉塵或煙霧。
- 請等待兒童和旁觀者離開之後才操縱電動工具。分心會導致您疏於控制。

2) 電氣安全

- 電動工具插頭必須與插座相符。切勿以任何方式改裝插頭。需接地的電動工具不能使用任何配接器插頭。使用未經改裝的插頭與相符的插座可降低觸電風險。
- 避免人體接觸接地表面,如管道、散熱片、爐灶和冰箱。若您身體接地,會提高觸電的風險。
- 不得將電動工具暴露在雨中或潮濕環境中。水進入電動工具會提高觸電風險。
- 切勿濫用電線。請勿使用電線來搬運、拉動電動工具或拔出插頭。讓電線遠離熱、油、銳邊和活動部件。受損或纏繞的電線會增加觸電危險。
- 若要在戶外使用電動工具,請使用適合戶外使用的延長電線。採用適合室外使用的電線可降低觸電危險。
- 若必須在潮濕環境中操作電動工具,請使用受漏電保護器(RCD)保護的電源供應器。使用RCD可降低觸電風險。

3) 人身安全

- 保持警覺;在操作電動工具時,請留意所執行的操作並按照一般的程式執行。請勿在疲倦或在受到毒品、酒精或藥品的影響時使用電動工具。操作電動工具時,一時的注意力分散可能會導致嚴重人身傷害。
- 使用個人防護裝置。始終佩戴**護目裝置**。防護設備(例如在適當條件下使用的防護面具、防滑安全鞋、安全帽或聽力保護裝置)可減少人身傷害。
- 避免意外啟動。連接電源及/或電池組、舉抬或搬運電動工具之前,請確定開關處於**關閉位置**。若搬運電動工具時將手指放在開關上,或者在電動工具開關開啟時將插頭插入電源插座,這兩種行為都會引發事故。
- 啟動電動工具之前,請卸下所有的調整鑰匙或扳手。遺留在電動工具旋轉部件上的扳手或鑰匙會導致人身傷害。
- 不要過度伸張雙手。時刻注意腳下與身體的平衡。如此可在意外情況下更好地控制電動工具。
- 適當穿著。請勿穿寬鬆衣服或佩戴飾品。讓您的頭髮、衣服和手套遠離活動部件。寬鬆衣服、佩飾或長髮可能會捲入活動部件中。
- 若配備用於連接排屑裝置、集塵設備的裝置,請確定正確連接和使用這些裝置。使用集塵設備可減少與粉塵有關的危險。
- 請勿因頻繁使用而對工具特別熟悉,讓你變得自滿而忽略工具的安全原則。粗心操作可以在片刻間造成嚴重傷害。

4) 電動工具的使用與注意事項

- 請勿超負荷使用電動工具。請根據您的應用使用正確的電動工具。**若使用的電動工具正確無誤，該工具能以設計額定值更有效、更安全地執行工作。
- 若開關不能開啟或關閉電源，切勿使用該電動工具。**若開關無法控制電動工具，則電動工具存在危險，必須予以維修。
- 在執行任何調整、更換配件或儲存工具之前，必須從電源上拔掉插頭及/或卸下電池組。**此類防護性安全措施可降低電動工具意外啟動的風險。
- 將閒置的電動工具儲存在兒童無法接觸的地方，並且不要讓不熟悉電動工具或對這些使用指示不瞭解的人員操作電動工具。**未經訓練的使用者操作電動工具會發生危險。
- 維護電動工具。檢查活動部件是否對準或卡住，是否存在任何破損情況，或任何能影響電動工具操作的其他情況。**若有損毀，必須在使用之前修理電動工具。許多事故都是由於電動工具欠缺維護所導致。
- 保持切割工具鋒利和清潔。**妥善維護、刀刃鋒利的刀具卡住的可能性更低，更易于控制。
- 使用電動工具、配件和工具刀頭等時，請遵循這些指示使用，且指示須包含工作環境和所要執行工作的注意事項。**若使用電動工具執行與設計用途不相符的操作，會導致危險。
- 手柄和抓握表面都應保持乾燥、清潔及遠離油脂。**光滑手柄和抓握表面不便於在意外情況下對工具進行安全處理與控制。

5) 檢修

- 維修本電動工具時，必須由合格的維修人員執行，而且只能使用完全一致的更換件。**這樣將確保電動工具的安全。

桌上型圓鋸機之安全指示

1) 防護相關警告

- 將防護罩固定到正確位置。防護罩必須能正常發揮作用，並正確安裝。**對於鬆動、受損或無法正常發揮作用的防護罩，必須予以維修或更換。
- 每次執行貫穿鋸切作業時，務必使用鋸片防護罩、分料刀及防反衝爪。**對於鋸片完全割穿工件厚度的貫穿鋸切作業，防護罩及其他安全裝置有助於降低受傷的風險。
- 完成需要卸下防護罩、分料刀及/或防反衝裝置的作業（例如開榫）後，立即重新連接防護系統。**防護罩、分料刀及防反衝裝置有助於降低受傷的風險。
- 開啟電源開關之前，確保鋸片不接觸防護罩、分料刀或工件。**不慎將這些物件與鋸片接觸可能會導致危險狀況。
- 按照本說明手冊所述調整分料刀。**間距、定位及對準不正確會導致分料刀無法降低反衝的可能性。
- 要確保分料刀及防反衝爪正常運作，必須與工件接合。**若切割的工件過短而無法與分料刀及防反衝爪接合，則分料刀及防反衝爪無效。在這些狀況下，分料刀及防反衝爪無法防止反衝。
- 針對分料刀使用適當的鋸片。**分料刀若要正常發揮作用，鋸片直徑必須與相應的分料刀相符，鋸片主體的厚度必須小於分料刀厚度，鋸片的切割寬度必須大於分料刀的厚度。

2) 鋸切程序警告

-  **危險：切勿將手指或手放在鋸片附近或與鋸片成直線。**一時的粗心或滑倒會使您的手迎向鋸片，導致嚴重人身傷害。

- 將工件送入鋸片或刀具時，只能採用與旋轉方向相反的送入方向。**若送入工件的方向與鋸片在桌上的旋轉方向相同，可能會導致將工件與您的手捲入鋸片。
- 縱剖時，切勿使用斜切規送入工件，使用斜切規進行橫剖時，請勿使用縱剖擋板作為縱向止動器。**同時使用縱剖擋板與斜切規引導工件將增大鋸片卡住及反衝的可能性。
- 執行縱剖時，務必在擋板與鋸片之間施加工件送入力。**若擋板與鋸片之間的距離小於 150 公釐，請使用推桿，若該距離小於 50 公釐，請使用推塊。「工作協助」裝置能使您的手與鋸片保持安全距離。
- 僅使用製造商提供的推桿或依照指示製造的推桿。**該推桿能在手與鋸片之間提供充足的距離。
- 切勿使用受損或經過切割的推桿。**受損的推桿可能會折斷，導致您的手滑入鋸片。
- 請勿「徒手」執行任何操作。務必使用縱剖擋板或斜切規對工件進行定位及引導。**「徒手」係指用手代替縱剖擋板或斜切規對工件進行支撐或引導。徒手鋸切會導致未對準、卡住及反衝。
- 切勿在鋸片旋轉時伸手到鋸片周圍或鋸片上方。**伸手拿工件可能會導致不慎接觸活動的鋸片。
- 對於很長及/或很寬的工件，在鋸桌的後面及/或側面提供輔助工件支撐，以保持工件水平。**很長及/或很寬的工件容易在桌邊旋轉，導致失去控制、鋸片卡住及反衝。
- 勻速送入工件。請勿彎曲或扭曲工件。**若出現卡住的狀況，請立即關閉工具電源，拔下工具的插頭，然後清理卡住的位置。若鋸片連工件卡住，會導致反衝或電機停轉。
- 請勿在鋸運轉期間取走切除的材料。**材料可能會困在擋板或鋸片防護罩與鋸片之間，會將您的手指拉入鋸片。請關閉圓鋸機電源，等候鋸片停止，然後再取走材料。
- 對厚度小於 2 公釐的工件進行縱剖時，使用與桌面接觸的輔助擋板。**太薄的工件可能會楔入縱剖擋板下方，並產生反衝。

3) 反衝原因與相關警告

反衝是由於鋸片遭壓緊、卡住或工件上的切割線未對準鋸片，或者工件的一部分卡在鋸片與縱剖擋板（或其他固定物件）之間時工件的突然反應。

反衝時最常見的狀況是鋸片的後部將工件從桌面上抬起，並將其推向操作人員。

反衝是由不當使用電鋸及/或錯誤的操作程序或條件所致，可透過採取以下提供的適當預防措施予以避免。

- 站立位置切勿與鋸片成直線。始終將身體與擋板置於鋸片的同一側。**反衝可能會將工件高速推向站在鋸片之前或站立位置與鋸片成直線的人員。
- 切勿伸手到鋸片的上方或後面拉動或支撐工件。**否則可能會不慎接觸鋸片，或者反衝可能會將您的手拖入鋸片。
- 切勿握住正在切除的工件並將其按壓在旋轉的鋸片上。**將正在切除的工件按壓在鋸片上會導致卡住與反衝。
- 使擋板與鋸片平行。**未對準的擋板會壓緊工件，使其緊靠鋸片，並產生反衝。
- 執行諸如開榫等非貫穿鋸切時，使用羽板引導工件，使其緊靠桌面與擋板。**羽板有助於在發生反衝時對工件進行控制。

- f) 妥當支撐大型板材，將鋸片遭壓緊及反衝的風險降至最低。大型板材由於自身重量而有下陷的傾向。必須在桌面上懸垂的所有板材部分下方放置支撐件。
- g) 對扭曲、打結、彎曲或沒有直邊的工件（無法使用斜切規或沿擋板進行引導）進行鋸切時格外小心。彎曲、打結或扭曲的工件不穩定，會導致鋸縫與鋸片無法對準以及卡住與反衝。
- h) 切勿鋸切垂直或水平堆疊的多個工件。鋸片會抬起一或多件工件，並導致反衝。
- i) 重新啟動電鋸時，若鋸片位於工件中，請將鋸片置於鋸縫中心，使鋸齒不接觸材料。若鋸片已卡住，則在電鋸重新啟動時可能會抬起工件，並導致反衝。
- j) 保持鋸片清潔、鋒利並妥善固定。切勿使用彎曲的鋸片或者鋸齒已破裂或折斷的鋸片。妥善固定的鋒利鋸片可將卡住、失速及反衝的狀況降至最低。

4) 圓鋸機操作程序警告

- a) 在卸下桌面的嵌入件、更換鋸片或者調整分料刀、防反衝爪或鋸片防護罩時，以及在機器無人看管時，請關閉圓鋸機電源並中斷圓鋸機與電源的連接。採取預防措施可以避免發生事故。
- b) 切勿使圓鋸機在無人看管的狀況下運轉。請關閉工具電源，不要離開工具，直到工具完全停止為止。運轉中無人看管的電鋸具有無法控制的危險。
- c) 將圓鋸機放置在光線良好、具有良好立足點並能保持良好平衡的水平位置。其安裝位置應該能提供足夠的空間以輕鬆處理特定大小的工件。狹窄昏暗的位置以及不平整的光滑地面會導致發生事故。
- d) 頻繁進行清潔並取走鋸桌下方及/或集塵裝置中的鋸屑。積存的鋸屑具有易燃性，可能會自燃。
- e) 必須固定圓鋸機。未正確固定的圓鋸機可能會移動或翻倒。
- f) 開啟圓鋸機電源之前，移走桌上的工具、木料碎片等。否則由此產生的分心或可能的堵塞會產生危險。
- g) 始終使用心軸孔的尺寸和形狀正確（菱形而不是圓形）的鋸片；與電鋸的安裝硬體不相符的鋸片會偏心運轉，導致失控。
- h) 對於諸如凸緣、鋸片墊圈、螺栓或螺母等安裝方式，切勿使用受損的或不正確的此類方式。這些安裝方式專為您的電鋸實現安全操作與最優效能而設計。
- i) 切勿站在圓鋸機上，請勿將其用作踏凳。若工具傾覆或不慎觸及切割工具，會產生嚴重傷害。
- j) 確保安裝的鋸片可以沿正確的方向旋轉。請勿對圓鋸機使用研磨砂輪、鋼絲刷或打磨砂輪。鋸片安裝不當或使用不建議的配件可能會導致嚴重傷害。

圓鋸機的其他安全規定



警告：在鋸切時，鋸切塑膠、塗有汁液的木材及其他材料可能會導致材料熔化並積聚在鋸片的鋸刃和本體上，從而增大鋸片過熱及卡住的風險。

- 避免採用不舒服的姿勢，否則突然的滑倒會導致將手捲入鋸片。
- 請勿在鋸片旋轉時嘗試取走鋸桌上鋸片附近的材料。
- 切勿將手伸到鋸切工具的後面或周圍以壓住工件。
- 使手臂、手及手指導離鋸片，以防止受到嚴重傷害。

- 使用適合自用的推桿將工件推過電鋸。推桿是木桿或塑膠桿，通常為製成，在工件的大小或形狀會導致將手放在與鋸片相距 152 公釐的範圍內時，應用推桿。
- 使用夾具、鑽模、固定物或羽板協助對工件進行引導與控制。當地代理商或授權服務中心可提供與您的工具搭配使用的配件（需要支付額外費用）。
- 請勿徒手執行縱剖、橫剖或其他任何作業。
- 切勿在鋸片旋轉時伸手到鋸片周圍或鋸片上方。
- 穩定性。在使用前，請確保將圓鋸機牢固安裝在固定表面上，使其不會移動。
- 應該將圓鋸機適當安裝在水平且平穩的表面上。工作區域應該不存在障礙物及絆倒的危險。不應將任何材料或工具緊靠在電鋸上。
- 切勿鋸切金屬、水泥板或石料。對於使用圓鋸機鋸切特定的人造材料，需遵循特殊指示。請始終遵循製造商的建議。否則可能會導致電鋸受損及人身傷害。
- 請勿安裝金剛石鋸片及嘗試將圓鋸機用作濕鋸。
- 必須始終將適當的中央蓋鎖定到位，以降低工件遭拋出及產生可能傷害的風險。
- 接觸鋸片時請戴手套。
- 針對要執行的作業使用正確的鋸片。鋸片必須向電鋸前方旋轉。請務必牢固擰緊鋸片心軸螺母。在使用前，請檢查鋸片的鋸齒是否受損或缺失。請勿使用受損或鈍的鋸片。
- 若未先關閉機器電源並中斷工具與電源的連接，切勿嘗試釋放失速的鋸片。若工件或切除的碎片困在鋸片防護罩裝配件內部，請先關閉電鋸電源，等候鋸片停止，然後再抬起鋸片防護罩裝配件並取走碎片。
- 為了降低工件遭拋出及產生人身傷害的風險，切勿在工件緊靠鋸片時啟動機器。
- 請勿使身體的任何部分與鋸片成直線。否則可能會導致人身傷害。請站在鋸片的任一側。
- 在機器運轉時，切勿在桌面/工作區域執行佈局、裝配或設定工作。突然的滑倒可能會導致將手捲入鋸片。可能會導致嚴重傷害。
- 在電鋸運轉時，切勿執行任何調整，例如擋板重新定位或卸下、斜面鎖定調整或鋸片高度調整。
- 在離開機器前清潔桌面/工作區域。將開關鎖定在「關」位置，並中斷工具與電源的連接，以防止發生未經授權的使用。
- 在鋸切前務必鎖定擋板及斜面調整。
- 避免鋸片尖端過熱。請保持材料移動，且移動方向平行於擋板。請勿將工件強力推入鋸片。
- 若鋸切塑膠材料，請避免塑膠熔化的。
- 請勿使長板（或其他工件）處於沒有支撐的狀態，否則板的跳動會導致其在桌面上移位，進而導致失去控制及發生可能的傷害。請根據工件的大小以及要執行的作業類型，為工件提供適當的支撐。將工件緊靠在擋板上，並緊壓在桌面上。
- 若此電鋸發出不熟悉的噪聲或過度振動，請立即停止作業，關閉機器電源，並中斷工具與電源的連接，直到找到並修正問題為止。若找不到問題，請聯絡 DeWALT 工廠服務中心、DeWALT 授權服務中心或其他有資質的服務人員。
- 在根據指示將機器完整裝配並安裝之前，請勿操作此機器。組裝不正確的機器會導致嚴重傷害。
- 切勿嘗試鋸切堆疊在一起的鬆散材料，否則可能會導致失去控制或反衝。請穩固支撐所有材料。

鋸片



警告：若要將反衝的風險降至最低，並確保正確鋸切，分料刀的厚度必須適合所用的鋸片。若使用不同的鋸片，請檢查鋸片上或鋸片包裝上所標記的鋸片主體（板）厚度及鋸片鋸縫（鋸切）寬度。分料刀的厚度必須大於主體的厚度，且小於鋸縫寬度。

- 請勿使用不符合**技術資料**所述尺寸的鋸片。請勿使用任何墊片使鋸片適合軸。若要對木料及類似材料進行鋸切，請僅使用本手冊中所指定之遵循 EN847-1 的鋸片。
- 請考慮使用特殊設計的降噪鋸片。
- 請勿使用硬鋼 (HS) 鋸片。
- 請勿使用破裂或受損的鋸片。
- 確保所選的鋸片適用於將鋸切的材料。
- 接觸鋸片及粗糙材料時請務必戴手套。在可行的狀況下，應使用容器搬運鋸片。

剩餘風險

使用圓鋸機時具有下列固有風險：

- 接旋轉部件造成的傷害

即使應用有關的安全規定並採用安全設備，仍然還有一些無法避免的剩餘風險。此類風險包括：

- 聽力受損。
- 旋轉鋸片的未遮蔽部件導致的事務風險。
- 使用不受保護的手更換鋸片時的受傷風險。
- 開啟防護裝置時夾傷手指的危險。
- 吸入鋸切木料（尤其是橡木、山毛櫸及MDF）時產生的粉塵而引起的健康危險。

以下因素對產生噪音的大小有影響：

- 要鋸切的材料
- 鋸片的類型
- 送入力
- 機器維護

以下因素對粉塵的產生有影響：

- 已磨損的鋸片
- 氣流速度低於 20m/s 的集塵器
- 未精確引導的工件

電氣安全

電動機只適用一種電壓。請務必檢查電源電壓是否與銘牌一致。



DeWALT 工具根據 IEC60745 進行雙重絕緣，因此不需要使用接地線。



警告：110V 裝置必須透過失靈安全隔離變壓器（在初級繞組與次級繞組之間使用接地屏蔽）才能運作。

若電源線受損，必須僅由 DeWALT 或授權的服務組織進行更換。

注意：此裝置用於連接到使用者供應器接入點（電力服務箱）處之最大允許系統阻抗 Z_{MAX} 為 0.28 Ω 的電源供應器系統。使用者必須確保將此裝置僅連接至符合上述需求的電力系統。若需要，使用者可以向公共電力供應公司詢問供應器接入點處的系統阻抗。

使用延長電纜

若需要使用延長電纜，請使用適合本工具功率輸入的認證 3 芯延長電纜（請參閱技術資料）。導體的最小橫截面積為 1.5 平方公釐；最大長度為 30 米。

使用電纜捲筒時，每次必須把電纜完全展開。

套裝內的物件

本套裝包括：

- 1 台 已部分裝配的桌上型圓鋸機
- 1 塊 縱割擋板
- 1 個 斜切規
- 1 個 上部鋸片防護罩裝配件
- 1 塊 中央蓋
- 2 個 鋸片扳手
- 1 個 分料刀扳手
- 1 個 推桿
- 1 個 集塵配接器
- 1 本 使用手冊

- 檢查工具、部件或配件有否在運送途中損壞。

- 操作前，請抽空徹底地閱讀和掌握本手冊的內容。

工具上的標誌

工具上會附帶下列圖示：



使用前請閱讀使用手冊。



請佩戴聽力保護器。



請佩戴護目鏡。



請佩戴呼吸保護裝置。



請讓雙手遠離鋸切區域與鋸片。



分料刀厚度



鋸片主體厚度與鋸縫寬度



鋸片直徑



主開關處的鎖定/解鎖護蓋。



在更換鋸片前拔出電鋸插頭





保護電源線/插頭，使其遠離潮濕及鋸片的銳邊

日期代碼位置 (圖 A)

日期代碼 **51**，包括製造年份，已經印刷在工具外殼上。

範例：

2020 XX XX

製造年份

說明 (圖 A, B)

警告：切勿改動本電動工具或其任何部件。否則可能導致損壞或人身傷害。

- 1 工作臺
- 2 鋸片 (台灣地區不包含鋸片)
- 3 縱割刻度尺指示器
- 4 微調旋鈕
- 5 導軌鎖定桿
- 6 鋸片高度調整輪
- 7 斜面鎖定桿
- 8 電源開關
- 9 安裝孔
- 10 斜切規
- 11 鋸片防護罩裝配件
- 13 分料刀
- 14 排塵口
- 15 防護罩排塵口
- 16 中央蓋
- 17 縱割擋板
- 18 縱割擋板門鎖
- 19 工件支撐/窄縱割擋板 (顯示在儲存位置中)
- 20 鋸片扳手
- 21 推桿 (顯示在儲存位置中)
- 50 搬運手柄
- 53 分料刀扳手
- 54 分料刀螺栓
- 55 固定件
- 56 分料刀壓板
- 57 防反衝集成
- 58 安裝軸
- 59 防反衝安裝槽

設計用途

DWE7492 圓鋸機專為對諸如木料、木料複合材料與塑膠等各種材料執行專業的縱割、橫割、斜角切割及斜面切割而設計。

請勿在潮濕有水或存有易燃液體或氣體的環境下使用本工具。

請勿用於鋸切金屬、水泥板或石料。

請勿在此電鋸上使用成形切刀頭。

請勿在沒有錐形鑽模配件的情況下執行錐形切割。

請勿使用此鋸執行切入式鋸切或內凹鋸切。

本圓鋸機是專業的電動工具。

請勿讓兒童接觸本工具。缺乏經驗的操作人員需要在監督下使用本工具。

- **兒童和體弱者。**兒童或體弱者在沒有他人監督的情況下不適宜使用本工具。體力、感覺或智力不足，以及缺乏經驗、知識或技能的人員(包括兒童)不適合使用本產品，除非一旁有能為他們安全負責的監督人員。請勿讓兒童單獨接觸本工具。

組裝



警告：為降低造成嚴重人身傷害的風險，在進行任何調整或卸下或安裝附件或配件之前，切記關閉工具並斷開工具電源。意外啟動工具可能會造成傷害。

打開包裝

- 從包裝材料中小心地取出電鋸。
- 除縱割擋板、鋸片防護罩裝配件、斜切規、鋸片扳手與集塵濾管口外，機器已完全裝配。
- 遵循以下所述的指示完成最終的裝配。



警告：不使用時，請務必將推桿固定到位。

安裝鋸片 (圖 A、C)



警告：若要降低傷害風險，請在安裝及卸下配件前、調整或變更設定前或進行維修時，關閉機器並斷開電源。意外啟動工具可能會造成傷害。



警告：安裝鋸片時，請戴保護手套。鋸片的鋸齒非常鋒利，可能很危險。



警告：更換鋸片時，必須遵循本部分所述內容。僅根據技術資料中指定的內容使用鋸片。我們建議使用 DT4226。切勿搭配使用其他鋸片。



警告：工作後在鋸片冷卻之前，請勿觸摸鋸片。工作時，鋸片的溫度可能會非常高。

注意：已在工廠中為本工具安裝了鋸片。

1. 順時鐘轉動鋸片高度調整輪 **6**，以便將鋸片心軸抬高至最大高度。
2. 卸下中央蓋 **16**。請參閱安裝中央蓋。
3. 使用扳手 **20** 逆時鐘轉動，在電鋸心軸上擰鬆並卸下心軸螺母 **22** 及凸緣 **24**。
4. 將鋸片放在軸 **23** 上，確保鋸片 **2** 的鋸齒在桌面前部指向下方。將墊圈與心軸螺母裝配到軸上，盡可能用手擰緊心軸螺母 **22**，確保鋸片緊靠內墊圈，且外凸緣 **24** 緊靠鋸片。確保凸緣的最大直徑緊靠鋸片。確保軸與墊圈上沒有灰塵及碎屑。
5. 若要防止軸在擰緊心軸螺母時發生旋轉，請使用鋸片扳手 **20** 的開口端將軸固定。
6. 使用心軸扳手，順時鐘轉動擰緊心軸螺母 **22**。
7. 裝回中央蓋。



警告：更換鋸片後，請務必檢查縱割擋板指針及鋸片防護罩裝配件。

安裝鋸片防護罩裝配件 (圖 A, D)



警告：請對所有貫穿鋸切使用防護罩裝配件。

1. 將鋸片 **2** 設定為最大切割深度。將其設為 45° 並鎖定。
2. 拆卸分料刀螺栓 **54** 和分料刀壓板 **56**。
3. 將分料刀 **13** 放在固定件 **55** 上并加上分料刀壓板 **56**。

4. 擰緊兩個分料刀螺栓 **54**，將其鎖定。

警告：將圓鋸機連接到電源或操作電鋸之前，請務必檢查鋸片防護罩裝配件與鋸片是否已正確對準並具有正確的間距。請在每次變更斜面角度後檢查對準狀況。

警告：為了降低發生嚴重人身傷害的風險，若未將鋸片裝配件牢固夾持到位，請勿操作電鋸。

正確對準時，分料刀 **13** 將在桌面及鋸片頂部與鋸片成直線。請使用直邊，確保鋸片 **2** 與分料刀 **13** 成直線。在中斷電源連接的狀況下，透過行程的極值對鋸片的傾斜度與高度進行調整，確保鋸片防護罩裝配件在所有作業中皆不影響鋸片運轉。請參閱**將防護罩裝配件/分料刀對準鋸片**。

警告：正確安裝與對準鋸片防護罩裝配件對安全作業而言不可或缺！

卸下鋸片防護罩裝配件 (圖 D)

1. 拆卸分料刀螺栓 **54**。
2. 取下分料刀壓板 **56** 和鋸片防護集成 **11**。

安裝中央蓋 (圖 E)

1. 按照圖 E 所示對準中央蓋 **16**，然後將中央蓋背面的凸耳插入到桌面開口背面的孔中。
2. 逆時針轉動凸輪，直到中央蓋正面到位。順時針轉動凸輪 1/4 圈鎖定手柄 **40** 進行固定 (如果凸輪鎖位於將中央蓋固定住的平台下)。
3. 中央蓋包括四枚調整螺釘 **25**，這些螺釘可以抬高或降低中央蓋。正確調整中央蓋後，中央蓋的前部應與桌面齊平或略低於桌面，並固定到位。中央蓋的後部應與桌面齊平或略高於桌面。

警告：切勿在沒有中央蓋的狀況下使用機器。中央蓋磨損或受損後，請立即予以更換。

安裝防反衝集成(圖 U)

警告：為減少嚴重人身傷害的風險，在所有切割中均必須安裝防反衝集成。

1. 從儲存位置取下防反衝集成 **57**。請參見儲存。
 2. 將防反衝安裝槽 **59** 置於分料刀 **13** 的頂部
 3. 將安裝軸 **58** 與安裝槽對齊。按壓安裝軸並將防反衝集成 **57** 推下，直到聽見吧嗒的聲音，表示其已經鎖定位。
- 注意：**拉動防反衝集成，確保它已經鎖定位。
4. 要取下防反衝集成，按壓安裝軸並向上將其拉出安裝槽。切斷電源后，在行程極限範圍內調整鋸片傾角和高度，確保鋸片防護罩集成在所有操作中都能讓鋸片順暢操作，同時防反衝集成也能正常操作。

安裝縱割擋板 (圖 F)

可將縱割擋板安裝於圓鋸機右側的兩個位置 (位置 1 適用於 0 公釐至 62 公分縱割，位置 2 適用於 20.3 公分至 82.5 公分縱割) 以及圓鋸機左側的一個位置。

1. 將縱割擋板門鎖 **18** 解除鎖定。
2. 以某角度握持擋板，將擋板導軌上的定位銷 (正面與背面) **29** 對準擋板頭插槽 **30**。
3. 將擋板頭插槽滑到定位銷上，然後向下旋轉擋板，直到其落在導軌上為止。
4. 在導軌上閉合正面與背面的門鎖 **18**，以便將擋板鎖定位。

安裝工作台 (圖 A)

小心：為了降低發生人身傷害的風險，請確保在使用前將圓鋸機牢固安裝在穩定表面上。

小心：請確保表面足夠穩定，在使用期間大塊材料不會導致表面翻倒。

必須牢固安裝圓鋸機。工具的底座上提供了用於安裝的四個孔 **9**。我們強烈建議使用這些孔將圓鋸機固定在工作台或其他靜止的剛性框架上。

1. 將圓鋸機放在邊長為 12.7 公釐的方形膠合板中央。
2. 使用鉛筆在圓鋸機的框架上標出後面兩個安裝孔 (相距 220 公釐) 的位置。然後向前測量 498.5 公釐，即為前面兩個孔的位置 (相距 230 公釐)。
3. 取下電鋸，在剛剛標記的位置鑽 9 公釐的孔。
4. 將電鋸放置在您在膠合板上所鑽的四個孔上方，然後從底部插入四枚 8 公釐機器螺釘。在頂部安裝墊圈與 8 公釐螺母。牢固擰緊。
5. 為了防止螺釘頭毀壞夾持電鋸的表面，請將兩根廢棄的木條連接至膠合板底座的底部。可以使用頂部安裝的木螺釘連接這些木條，只要這些螺釘不會伸出木條的底部即可。
6. 在使用圓鋸機時，使用「C」夾具將膠合板底部固定在工作台上。

調整

鋸片調整 (圖 G)

鋸片對準 (平行於斜槽)

警告：存在切割危險。在 0° 與 45° 位置檢查鋸片，以確保鋸片不會碰到中央蓋導致人身傷害。

若鋸片似乎並未對準桌面上的斜槽，則需要進行校準以實現對準。若要重新對準鋸片與斜槽，請使用以下程序：

警告：若要降低傷害危險，請在安裝和移除配件前、調整或變更設定前或進行修理時關閉工具並斷開電源。意外啟動工具可能會造成傷害。

1. 使用 5 公釐六角扳手，擰鬆位於桌面下面的後樞軸支架緊固件 **32**，只要足以能使支架左右移動即可。
2. 調整支架，直到鋸片平行於斜切規槽為止。
3. 以 12.5–13.6 Nm (110–120 in-lbs) 的力矩擰緊後樞軸支架緊固件。

鋸片高度調整 (圖 A)

可以轉動鋸片高度調整輪 **6** 以升高及降低鋸片。

鋸切時，請確保鋸片頂部的三個鋸齒恰好穿過工件的上表面。這會確保在任何指定時間都會有最大數量的鋸齒在移除材料，因此能提供最優的效能。

將防護罩裝配件/分料刀對準鋸片

(圖 A、H)

1. 卸下中央蓋。請參閱**卸下中央蓋**。
2. 抬高鋸片至完整切割深度，採用 0° 斜面角度。
3. 找到與防護罩裝配件鎖定軸 **38** 相鄰的三枚小型固定螺釘 **39**。這些螺釘將用於調整防護罩裝配件的位置。
4. 將直邊放在桌面上，使其緊靠兩個鋸片齒尖。分料刀 **13** 不應接觸直邊。若需要，請擰鬆兩枚較大的鎖定螺釘 **41**。
5. 調整小型固定螺釘 **39**，以便根據第 4 步註明的位置移動分料刀。將直邊放在鋸片的另一側，然後視需要重複執行調整。
6. 略微擰緊兩枚較大的鎖定螺釘 **41**。

- 將直角尺緊靠分料刀，以驗證分料刀是否與鋸片垂直及成直線。
- 若需要，請使用固定螺釘使分料刀與直角尺垂直。
- 重複第 4 與第 5 步以驗證分料刀的位置。
- 完全擰緊兩枚較大的鎖定螺釘 **41**。
- 重新安裝並鎖定中央蓋 **16**。

平行調整(圖 A、I、J、O)

警告：未對準的擋板(不平行於鋸片)會增大反衝的風險!

若要取得最優效能，鋸片必須平行於縱割擋板。已在工廠中執行此項調整。若要重新執行調整：

位置 1 擋板調整

- 在位置 1 安裝擋板，並將導軌鎖定桿 **5** 解除鎖定。在前後導軌上找到為擋板提供支撐的兩個定位銷 **29**。
- 擰鬆後定位銷螺釘，調整擋板在槽中的對準位置，直到擋板面與鋸片平行為止。請確保從擋板面到鋸片前部及後部進行量測，以確保對準。
- 擰緊定位螺釘，然後在鋸片的左側重複上述步驟。
- 檢查縱割刻度尺指針調整(圖 J)。

位置 2 擋板調整

- 若要對準位置 2 擋板定位銷 **29**，請確保已對準位置 1 的定位銷，請參閱 **位置 1 擋板對準**。
- 鬆開位置 2 的定位銷，然後使用鋸片扳手孔作為定位引導，對準定位銷(圖 O)。
- 擰緊定位銷(前面與後面)。

調整縱割刻度尺(圖 A、J)

- 將導軌鎖定桿 **5** 解除鎖定。
- 以 0° 斜面角度固定鋸片，並移動擋板，直到其接觸鋸片為止。
- 鎖定導軌鎖定桿。
- 擰鬆縱割刻度尺指示器螺釘 **31**，然後將縱割刻度尺指示器的讀值設為零(0)。重新擰緊縱割刻度尺指示器螺釘。只有在將擋板安裝在鋸片右側，且位於位置 1(適用於零至 62 公分縱割)而非 82.5 公分縱割位置時，才能正確讀取黃色的縱割刻度尺(頂部)。只有在將擋板安裝在鋸片右側，且位於位置 2(適用於 20.3 公分至 82.5 公分縱割)時，才能正確讀取白色的刻度尺(底部)。

只有在將擋板安裝在鋸片右側時，才能正確讀取縱割刻度尺。

導軌鎖定調整(圖 A、K)

已在工廠中設定導軌鎖定。若您需要重新調整，請按照以下所示執行：

- 鎖定導軌鎖定桿 **5**。
- 在電鋸的下方，擰鬆防鬆螺母 **33**。
- 擰緊六角棒 **34**，直到鎖定系統上的彈簧受到壓縮，從而在導軌鎖定桿上產生所需的張力為止。重新擰緊緊靠六角棒的防鬆螺母。
- 將電鋸翻轉，檢查擋板在鎖定桿接合時是否不會移動。若擋板仍鬆動，請進一步壓緊彈簧。

斜面止動位置與指針調整(圖 L)

- 順時鐘旋轉鋸片高度調整輪 **6**，直到其停止為止，以便完全抬高鋸片。

- 向上推動斜面鎖定桿 **7** 並將其推至右側，以便將其解除鎖定。擰鬆斜面上止動位置螺釘 **36**。
- 放置直角尺，使其緊靠桌面並緊靠鋸片的鋸齒。確保斜面鎖定桿處於解除鎖定(即向上)的位置。
- 使用斜面鎖定桿，調整斜面角度，直到鋸片貼靠直角尺為止。
- 向下推動斜面鎖定桿以將其緊固。
- 轉動斜面上止動位置凸輪 **35**，直到其牢固接觸軸承座為止。擰緊斜面上止動位置螺釘 **36**。
- 檢查斜面角度刻度尺。若指針的讀值不是 0°，請擰鬆指針螺釘 **37**，並移動指針，使其讀值正確。重新擰緊指針螺釘。
- 在 45° 位置重複上述操作，但不調整指針。

斜切規調整(圖 A)

若要調整斜切規 **10**，請擰鬆旋鈕，設為所需的角，然後擰緊旋鈕。

身體和手的位置

在操作圓鋸機時，若身體與手處於正確的位置，可以更輕鬆、更準確、更安全地進行切割。



警告：

- 手切勿靠近切割區域。
- 雙手距離鋸片的距離不小於 150 公釐。
- 請勿交叉雙手。
- 請雙足平穩地站在地上，保持正常的身體平衡。

操作之前



警告：

- 安裝合適的鋸片。請勿使用過度磨損的鋸片。工具最大轉速切勿超過鋸片的最大速度。
- 請勿嘗試切割過小的工件。
- 讓鋸片自由切割。請勿使用強力。
- 切割前使電機達到全速。

操作

使用說明



警告：務必遵守安全指示和適用的規則。



警告：為了降低造成嚴重人身傷害的風險，在進行任何調整或卸下或安裝附件或配件之前，切記關閉工具並斷開工具電源。意外啟動工具可能會造成傷害。

請確保鋸片放置在工作臺高度及穩定度方面符合人體工學要求的位置。應為操作人員選擇擁有良好視野及充分自由活動空間的操作場所，以便操作人員在不受限制的情況下處理工件。

若要降低越來越大振動產生的影響，請確保環境不太冷、機器與配件維護良好，且工件大小適合此機器處理。



警告：

- 請確保鋸片的位置在工作台高度及穩定度方面符合人體工學要求。應為操作人員選擇擁有良好視野及充分自由活動空間的操作場所，以便操作人員在不受限制的情況下處理工件。
- 安裝合適的鋸片。請勿使用過度磨損的鋸片。工具最大轉速切勿超過鋸片的最大速度。
- 請勿嘗試切割過小的工件。
- 讓鋸片自由切割。請勿使用強力。
- 切割前使電機達到全速。

- 確保所有鎖定旋鈕與夾具手柄皆已旋緊。
- 將電鋸連接至電源後，切勿將手放在鋸片區域。
- 切勿使用此電鋸執行徒手切割！
- 請勿鋸切彎曲、弧形或凹形的工件。必須至少有一個光滑直邊緊靠縱割擋板或斜切擋板。
- 務必為長工件提供支撐，以防止反衝。
- 在鋸片運轉時，請勿從鋸片區域取走切除的材料。

開啟與關閉電源(圖 M)

電鋸工作台的電源開關 **8** 具有多項優點：

- 無電壓釋放功能：若電力因故中斷，必須有意重新啟動電源開關。
- 若要打開機器電源，請按下綠色的啟動按鈕。
- 若要關閉機器電源，請按下紅色的停止按鈕。

鎖閉功能指示

開關上方的護蓋可以折疊，以便插入掛鎖以鎖閉電鋸。建議使用最大直徑為 6.35 公釐且最小間距為 76.2 公釐的掛鎖。

縱割擋板作業(圖 N-P)

導軌鎖定桿

導軌鎖定桿 **5** 會將擋板鎖定到位，防止在鋸切期間發生移動。若要鎖定導軌桿，請將其向下推，並推向電鋸的後部。若要解除鎖定，請將其向上推，並推向電鋸的前部。

註：縱割時，請務必鎖定導軌鎖定桿。

工件支撐延長/窄縱割擋板

本圓鋸機具有工件支撐延長功能，以便為延伸到鋸桌之外的工件提供支撐。

若要在工件支撐位置使用窄縱割擋板，請從儲存位置旋轉該擋板，如圖 O 所示，然後將銷滑入擋板兩端較低的插槽組 **27** 中。

若要在窄縱割位置使用窄縱割擋板，請將銷插入擋板兩端較高的插槽組 **28** 中。此功能可將提供支撐的距鋸片的距離延長 51 公釐。請參閱圖 P。

註：在桌上工作時，請撤銷工件支撐延長功能或將其調整至窄縱割擋板位置。

註：使用窄縱割擋板時，請將所示的縱割刻度尺讀值減去 51 公釐。

微調旋鈕

使用微調旋鈕 **4** 可以在固定擋板時進行更微小的調整。在調整之前，請確保導軌鎖定桿處於向上（即解除鎖定）的位置。

縱割刻度尺指針

若使用者在薄厚鋸縫鋸片間進行切換，則需要調整縱割刻度尺指針才能使縱割擋板正常發揮作用。只有在將擋板安裝在鋸片右側的位置 1 或 2 時，縱割刻度尺指針的讀值才正確。使用窄縱割擋板執行窄縱割時（不在工件支撐位置），請將所示的縱割刻度尺讀值減去 51 公釐。請參閱調整下的調整縱割刻度尺。

防護罩操作特點(圖 V)



警告：為降低受傷風險，請先關閉工具，切斷機器電源，然後再安裝或拆卸配件，調整或改動設置，或進行維修。意外啟動會造成人身傷害。

1. 透明的側邊防護罩在拉起位置上將被鎖定。
2. 這一特色能在測量鋸片距離格柵的距離時增加可見度。
3. 推下防護蓋，它們將恢復到操作位置。

注意：拉動防反衝集成，確保它鎖定到位。在操作前，務必確保兩側的防護蓋均處於下方位置，並與檯面接觸

基本鋸切

貫穿鋸切操作



警告：請對所有貫穿鋸切作業使用鋸片防護罩裝配件。

縱割(圖 A、B、Q、R)



警告：小心銳邊。

1. 將鋸片設為 0°。
2. 安裝縱割擋板並鎖定縱割擋板門鎖 **18** (圖 A)。
3. 抬高鋸片，直到其高於工件頂部約 3 公釐為止。視需要調整上部鋸片防護罩的高度。
4. 調整擋板的位置，並鎖定導軌鎖定桿 **5**，請參閱縱割擋板作業。
5. 將工件平放在桌面上，並緊靠擋板。使工件遠離鋸片。
6. 使雙手遠離鋸片的運轉路徑 (圖 Q)。
7. 打開機器電源，讓鋸片達到全速。
8. 在防護罩下緩慢送入工件，始終用力按壓使工件緊靠縱割擋板。讓鋸齒執行鋸切，不要強制工件通過鋸片。鋸片速度應保持不變。
9. 在工件接近鋸片時 (圖 R) 務必使用推桿 **21**。
10. 完成鋸切後，關閉機器電源，讓鋸片停止運轉，然後卸下工件。



警告：

- 切勿推動或握住工件的「自由」端或遭切除的一端。
- 請勿鋸切過小的工件。
- 縱割小工件時，務必使用推桿。

斜面切割(圖 A)

1. 若要設定所需的斜面角度，請將斜面鎖定桿向上推，並推向右側，以旋轉斜面鎖定桿 **7**。
2. 若要設定所需的角度，請將桿向下推，並推向左側以鎖定到位，以旋轉該桿。
3. 然後執行縱割。

橫割與斜面橫割(圖 Q)

1. 卸下縱割擋板，然後在所需的槽中安裝斜切規。
2. 將斜切規鎖定在 0°。
3. 然後執行縱割。

斜角切割(圖 A)

1. 將斜切規 **10** 設為所需角度。

注意：務必緊握工件，使其緊靠斜切規的面。

2. 然後執行縱割。

複合式斜切

此鋸切作業是斜角切割與斜面切割的組合。將斜面設為所需的角度，然後執行斜角橫割。

對長工件使用支架

- 請務必對長工件提供支撐。
- 請使用任何便利方式(例如鋸木架或類似裝置)支撐長工件，以免末端掉落。



集塵 (圖 A、AA)

此機器在後部具有排塵口 **14**，適合搭配使用具有 57/65 公釐卡槽的集塵設備。此機器隨附減徑管口，以使用 34–40 公釐直徑的集塵卡槽。

此機器隨附減徑管口，可搭配使用 DEWALT AirLock 系統 (DWW9000-X)。鋸片防護罩裝配件還具有適用於 35 公釐卡槽的排塵口，或者可以直接連接至 DEWALT AirLock (DWW9000-X)。

諸如含鉛塗層及某些木材類型等材料產生的灰塵可能對人的健康有害。吸入灰塵會導致發生過敏反應及/或導致使用者或旁觀者出現呼吸道感染。

某些灰塵 (諸如樺木或山毛櫸產生的灰塵) 有致癌作用，尤其是與木材處理添加劑相關的灰塵，更是如此。

請遵循您的國家/地區對要處理的材料佈的相關規章。

真空吸塵器必須適用於要處理的材料。

對乾燥的灰塵 (尤其是有害健康或有致癌作用的灰塵) 進行吸塵時，請使用 M 級真空吸塵器。

鋸片防護罩裝配件還具有適用於 35 公釐卡槽 (M 級真空吸塵器) 的排塵口。

- 在所有作業中，請連接根據排塵相關法規而設計的集塵裝置。
- 確保所用的集塵軟管適用於要執行的應用及要鋸切的材料。確保執行適當的軟管管理。
- 請注意，在鋸切過程中，人造材料 (例如硬紙板或 MDF) 產生的灰塵顆粒多於天然木料。

儲存 (圖 B、X–Z)

不使用時，請安全儲存本機器。儲存地點必須乾燥且可以上鎖。這可以防止機器受到儲存損傷，也可以防止未經訓練的人員操作機器。

1. 將推桿 **21** 連接至擋板。
2. 卸下鋸片防護罩裝配件。請參閱**卸下鋸片防護罩裝配件**。將鋸片防護罩裝配件 **11** 滑入所示容器，然後轉動鎖定旋鈕 1/4 週以鎖定到位。請參閱圖 X。
3. 將鋸片扳手 **20** 滑入槽中，直到黃色按鈕對準孔為止，以便固定到位，請參閱圖 B。
4. 將斜切規的導桿插入至槽中，直到其降至最低點為止。
5. 將電源線纏繞在此位置 **43**。請參閱圖 Z。
6. 若要儲存擋板，請將工件支撐扣到儲存位置。從導軌上卸下擋板。在電鋸左側以倒置方式重新連接擋板，請參閱圖 Y。請勿將定位槽勾在左側擋板定位螺釘上。這些螺釘將對準擋板上的間距槽。閉合縱割擋板門鎖 **18** 以固定。

儲存 (圖 BB)

1. 按壓防反衝集成 **57** 上的安裝軸，讓集成能夠在分料刀的滑槽上滑動。
2. 如圖所示，將放反衝集成放入儲存孔中。按壓安裝軸 **58** 時，將放反衝集成沿著儲存支架 **60** 滑動并用銷釘將其鎖定到位。

運輸 (圖 A、B)

在運輸前，必須執行以下作業：

- 纏繞電源線
- 逆時鐘方向轉動鋸片高度調整輪 **6**，直到鋸片的鋸齒位於鋸桌下方為止。鎖定斜面鎖定桿 **7**。
- 將擋板導軌完全向內滑動，並使用導軌鎖定桿 **5** 將其固定。
- 務必使用指定的手柄 **50** 搬運機器，請參閱圖 A 與圖 B。



警告：運輸機器時，務必安裝上部鋸片防護罩。

維護

DEWALT 電動工具採用卓越的設計，能夠長時間使用，並且只需最少的維護。若要持續獲得滿意的操作效果，需進行正確的工具維護和定期的清潔。



警告：為了減低造成嚴重人身傷害的風險，在進行任何調整或卸下或安裝附件或配件之前，切記關掉工具的電源並取出電池組。意外啟動工具可能會造成傷害。



潤滑 (圖 T)

電機與軸承無需額外潤滑。若很難抬高及降低鋸片，請清潔高度調整螺釘並為其塗上油脂：

1. 從電源拔出電鋸插頭。
2. 翻轉電鋸。
3. 清潔並潤滑此電鋸下方的高度調整螺釘螺紋 **42**，如圖 T 所示。請使用通用油脂。



清潔 (圖 A, S)



警告：為了降低發生嚴重人身傷害的風險，請先關閉機器，並斷機器與電源的连接，然後再執行清潔。意外啟動工具可能會造成傷害。



警告：一旦通風口及其周圍積聚可見的粉塵，請立即使用乾燥的壓縮空氣吹掉主機外殼內的粉塵和灰塵。執行此步驟時，請佩戴經認可的護目裝備和防塵面罩。



警告：切勿使用溶劑或其他刺激性化學品來清潔工具的非金屬部件。這些化學品可能會削弱部件中使用的材料。只能使用抹布蘸中性肥皂水進行清潔。不要讓任何液體進入工具；不要讓工具的任何部分浸入液體中。



警告：為降低傷害風險，請定期清潔桌面。



警告：為降低傷害風險，請定期清潔集塵系統。

必須先將鋸片防護罩裝配件 **11** 及中央蓋放置到適當位置，然後再操作電鋸。

使用前，請仔細檢查上部與下部鋸片防護罩以及集塵管，以確定其能正常工作。確保碎屑、灰塵或工件顆粒不會阻礙其中任一功能。

若工件碎屑導致鋸片與防護罩之間發生堵塞，請中斷機器與電源供應器的連接，並依據安裝鋸片部分中的指示進行操作。卸下堵塞的零件，然後重新組裝鋸片。

保持通風槽無堵塞，並定期使用軟布清潔外殼。

定期清潔集塵系統：

1. 拔出電鋸的電源插頭。
2. 翻轉電鋸，以便可以處理機器底部的開放部分。
3. 打開灰塵檢視門 **44**，如圖 S 所示，擰鬆兩枚螺釘，然後以彼此相向的方式按下邊夾 **45**。清除多餘的灰塵，然後將邊夾完全按壓到位，並擰緊鎖定螺釘，以便重新固定。

選購配件



警告：由於非 DeWALT 所提供的配件未在本產品上進行過使用測試，在本產品上使用這些附件可能發生危險。為降低傷害危險，在本產品上只應使用 DeWALT 所推薦的配件。

如需進一步瞭解適用配件的相關資訊，請洽詢當地代理商。

鋸片防護罩若已磨損，請予以更換。如需有關鋸片防護罩更換的詳細資料，請聯絡當地的 DeWALT 服務中心。

鋸片：請務必使用具有 16 公釐心軸孔的 254 公釐降噪鋸片。鋸片額定轉速必須至少為 5000 RPM。切勿使用直徑更小的鋸片。否則鋸片將無法受到正常的保護。

鋸片描述

應用	直徑	齒數
建造鋸片 (快速縱剖)		
一般用途	254 公釐	24
精細橫切	254 公釐	40
木工鋸片 (提供平滑、潔淨的鋸切)		
精細橫切	254 公釐	60

如需進一步瞭解適用配件的相關資訊，請洽詢當地代理商。

- DWE74911 滾動圓鋸機支架
- DWE74912 剪刀腿支架

保護環境



分類回收。帶有此標誌的產品和電池必須與一般家庭廢物分開處置。

產品和電池包含可重複使用或回收的材料，可降低對原材料的需求。請根據當地法規回收電氣產品和電池。更多資

訊，請造訪 www.2helpU.com。

售後服務和維修

- DeWALT 服務中心擁有經過培訓的工作人員，能夠為顧客提供高效而可靠的產品服務。
- 如果您已經在未獲授權的服務中心維修了產品，我們將不承擔任何責任。您可以參見產品包裝中的“客服中心位置”單頁，並通過熱線電話、網站或社交媒體聯繫我們，尋找距離您最近的 DeWALT 服務中心。

進口商：新加坡商百得電動工具（股）公司台灣分公司

地址：台北市士林區德行西路 33 號 2 樓

電話：02-28341741

總經銷商：永安實業股份有限公司

地址：新北市三重區新北大道二段 137 號

電話：02-29994633

