

DEWALT®

XR®

www.DEWALT.com

DCMCS574

DCMCS575

English (*original instructions*)

3

简体中文

17

Fig. A
图A

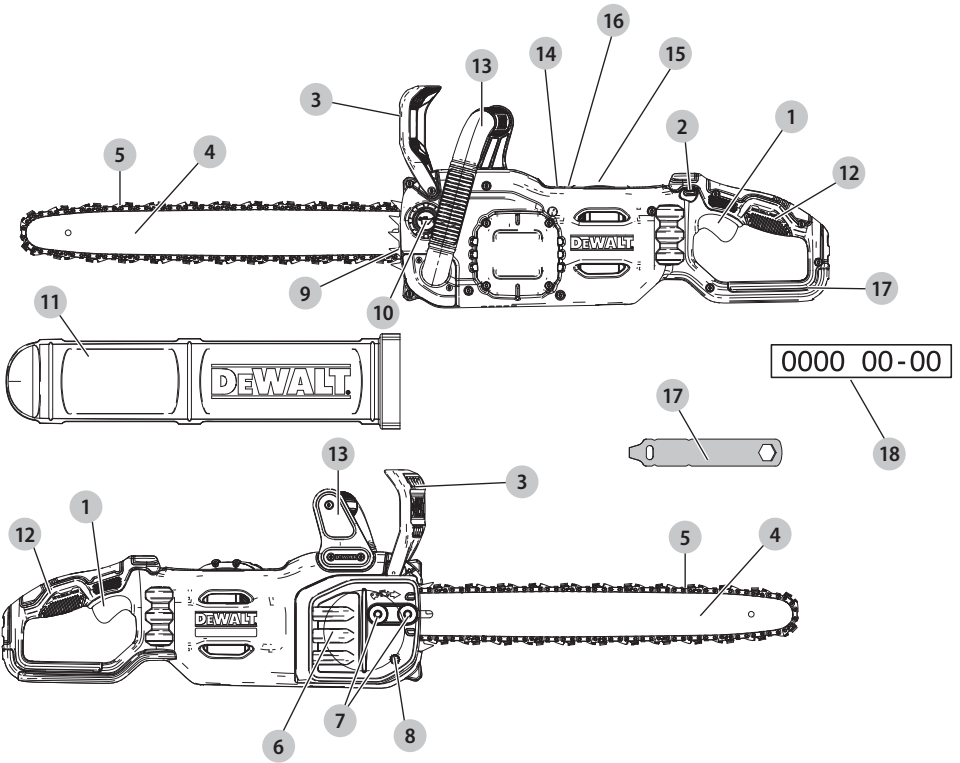

Fig. B
图B

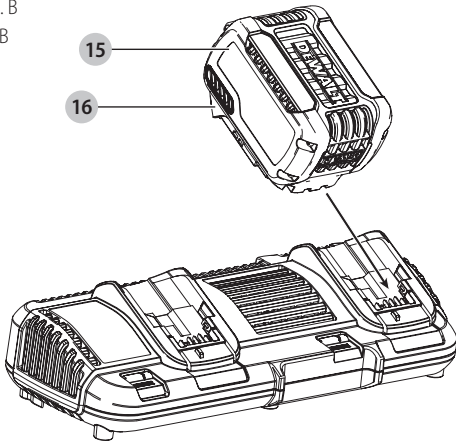

Fig. C
图C

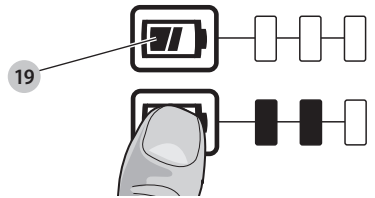

Fig. D
图D

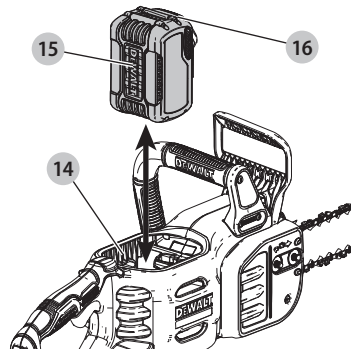

Fig. E
图E

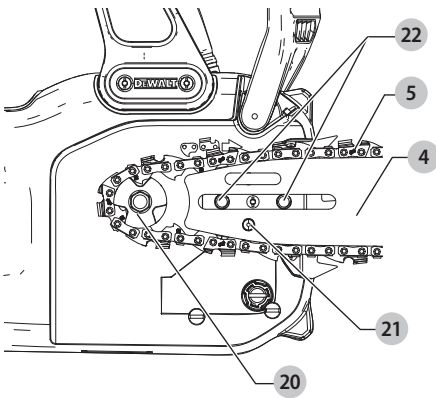

Fig. F
图F

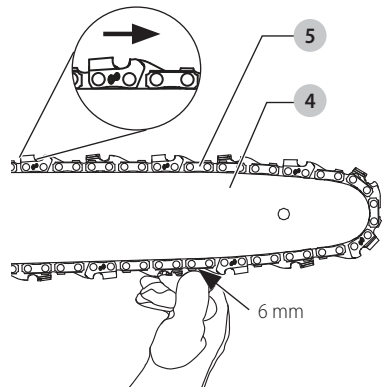

Fig. G
图G

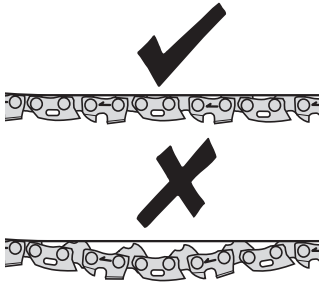

Fig. H
图H

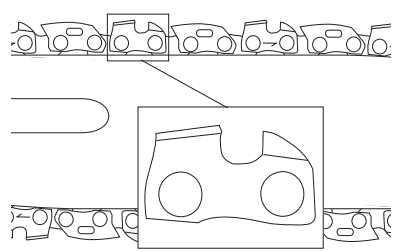

Fig. I
图I

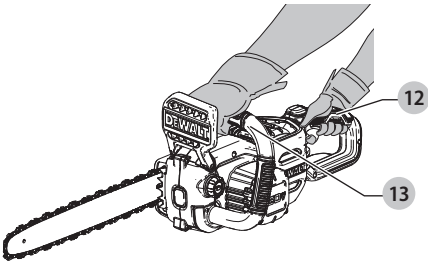

Fig. J
图J

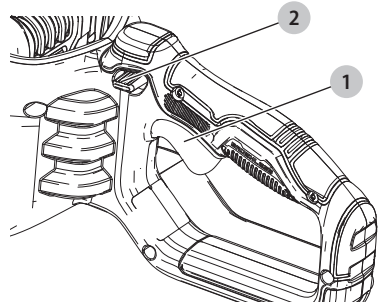
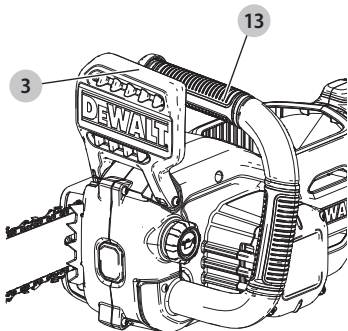

Fig. K
图K



54V CHAINSAW

DCMCS574, DCMCS575

Congratulations!

You have chosen a DEWALT tool. Years of experience, thorough product development and innovation make DEWALT one of the most reliable partners for professional power tool users.

Technical Data

		DCMCS574	DCMCS575
Voltage	V _{DC}	54 (60 Max)	54 (60 Max)
Battery type		Li-Ion	Li-Ion
Bar Length	cm	45	50
Chain Speed	m/s	13.5	13.5
Maximum Cutting Length	cm	40	45
Oil Capacity	ml	115	115
Weight (without battery pack)	kg	5	5.7

Batteries				Chargers / Charge Times (Minutes)						
Cat#	V _{DC}	Ah	Weight(kg)	DCB104	DCB107	DCB112	DCB115	DCB117 DCB1112	DCB118	DCB132
DCB546/DCB606	18/54 (20/60 Max)	6.0/2.0	1.08	60	270	170	90	40	60	90
DCB547/DCB609	18/54 (20/60 Max)	9.0/3.0	1.46	75*	420	270	135*	60	75*	135*
DCB548/DCB612	18/54 (20/60 Max)	12.0/4.0	1.46	120	540	350	180	80	120	180
DCB549/DCB615	18/54 (20/60 Max)	15.0/5.0	2.12	125	730	450	230	90	125	230

*Date code 201811475B or later

**Date code 201536 or later



WARNING: To reduce the risk of injury, read the instruction manual.

Definitions: Safety Guidelines

The definitions below describe the level of severity for each signal word. Please read the manual and pay attention to these symbols.



DANGER: Indicates an imminently hazardous situation which, if not avoided, **will** result in **death or serious injury**.



WARNING: Indicates a potentially hazardous situation which, if not avoided, **could** result in **death or serious injury**.



CAUTION: Indicates a potentially hazardous situation which, if not avoided, **may** result in **minor or moderate injury**.

NOTICE: Indicates a practice **not related to personal injury** which, if not avoided, **may** result in **property damage**.



Denotes risk of electric shock.



Denotes risk of fire.

GENERAL POWER TOOL SAFETY WARNINGS



WARNING: Read all safety warnings, instructions, illustrations and specifications provided with this power tool. Failure to follow all instructions listed below may result in electric shock, fire and/or serious injury.

SAVE ALL WARNINGS AND INSTRUCTIONS FOR FUTURE REFERENCE

The term "power tool" in the warnings refers to your mains-operated (corded) power tool or battery-operated (cordless) power tool.

1) Work Area Safety

- Keep work area clean and well lit.** Cluttered or dark areas invite accidents.
- Do not operate power tools in explosive atmospheres, such as in the presence of flammable liquids, gases or dust.** Power tools create sparks which may ignite the dust or fumes.
- Keep children and bystanders away while operating a power tool.** Distractions can cause you to lose control.

2) Electrical Safety

- Power tool plugs must match the outlet. Never modify the plug in any way. Do not use any adapter plugs with earthed (grounded) power tools.**

Unmodified plugs and matching outlets will reduce risk of electric shock.

- b) **Avoid body contact with earthed or grounded surfaces, such as pipes, radiators, ranges and refrigerators.** There is an increased risk of electric shock if your body is earthed or grounded.
- c) **Do not expose power tools to rain or wet conditions.** Water entering a power tool will increase the risk of electric shock.
- d) **Do not abuse the cord. Never use the cord for carrying, pulling or unplugging the power tool. Keep cord away from heat, oil, sharp edges or moving parts.** Damaged or entangled cords increase the risk of electric shock.
- e) **When operating a power tool outdoors, use an extension cord suitable for outdoor use.** Use of a cord suitable for outdoor use reduces the risk of electric shock.
- f) **If operating a power tool in a damp location is unavoidable, use a residual current device (RCD) protected supply.** Use of an RCD reduces the risk of electric shock.

3) Personal Safety

- a) **Stay alert, watch what you are doing and use common sense when operating a power tool. Do not use a power tool while you are tired or under the influence of drugs, alcohol or medication.** A moment of inattention while operating power tools may result in serious personal injury.
- b) **Use personal protective equipment. Always wear eye protection.** Protective equipment such as a dust mask, non-skid safety shoes, hard hat or hearing protection used for appropriate conditions will reduce personal injuries.
- c) **Prevent unintentional starting. Ensure the switch is in the off-position before connecting to power source and/or battery pack, picking up or carrying the tool.** Carrying power tools with your finger on the switch or energising power tools that have the switch on invites accidents.
- d) **Remove any adjusting key or wrench before turning the power tool on.** A wrench or a key left attached to a rotating part of the power tool may result in personal injury.
- e) **Do not overreach. Keep proper footing and balance at all times.** This enables better control of the power tool in unexpected situations.
- f) **Dress properly. Do not wear loose clothing or jewellery. Keep your hair and clothing away from moving parts.** Loose clothes, jewellery or long hair can be caught in moving parts.
- g) **If devices are provided for the connection of dust extraction and collection facilities, ensure these are connected and properly used.** Use of dust collection can reduce dust-related hazards.
- h) **Do not let familiarity gained from frequent use of tools allow you to become complacent and ignore tool safety principles.** A careless action can cause severe injury within a fraction of a second.

4) Power Tool Use and Care

- a) **Do not force the power tool. Use the correct power tool for your application.** The correct power tool will do the job better and safer at the rate for which it was designed.
- b) **Do not use the power tool if the switch does not turn it on and off.** Any power tool that cannot be controlled with the switch is dangerous and must be repaired.
- c) **Disconnect the plug from the power source and/or remove the battery pack, if detachable, from the power tool before making any adjustments, changing accessories, or storing power tools.** Such preventive safety measures reduce the risk of starting the power tool accidentally.
- d) **Store idle power tools out of the reach of children and do not allow persons unfamiliar with the power tool or these instructions to operate the power tool.** Power tools are dangerous in the hands of untrained users.
- e) **Maintain power tools and accessories. Check for misalignment or binding of moving parts, breakage of parts and any other condition that may affect the power tool's operation. If damaged, have the power tool repaired before use.** Many accidents are caused by poorly maintained power tools.
- f) **Keep cutting tools sharp and clean.** Properly maintained cutting tools with sharp cutting edges are less likely to bind and are easier to control.
- g) **Use the power tool, accessories and tool bits etc. in accordance with these instructions, taking into account the working conditions and the work to be performed.** Use of the power tool for operations different from those intended could result in a hazardous situation.
- h) **Keep handles and grasping surfaces dry, clean and free from oil and grease.** Slippery handles and grasping surfaces do not allow for safe handling and control of the tool in unexpected situations.

5) Battery Tool Use and Care

- a) **Recharge only with the charger specified by the manufacturer.** A charger that is suitable for one type of battery pack may create a risk of fire when used with another battery pack.
- b) **Use power tools only with specifically designated battery packs.** Use of any other battery packs may create a risk of injury and fire.
- c) **When battery pack is not in use, keep it away from other metal objects, like paper clips, coins, keys, nails, screws or other small metal objects, that can make a connection from one terminal to another.** Shorting the battery terminals together may cause burns or a fire.
- d) **Under abusive conditions, liquid may be ejected from the battery; avoid contact. If contact accidentally occurs, flush with water. If liquid contacts eyes, additionally seek medical help.** Liquid ejected from the battery may cause irritation or burns.
- e) **Do not use a battery pack or tool that is damaged or modified.** Damaged or modified batteries may exhibit

unpredictable behaviour resulting in fire, explosion or risk of injury.

- f) **Do not expose a battery pack or tool to fire or excessive temperature.** Exposure to fire or temperature above 130 °C may cause explosion.
- g) **Follow all charging instructions and do not charge the battery pack or tool outside the temperature range specified in the instructions.** Charging improperly or at temperatures outside the specified range may damage the battery and increase the risk of fire.

6) Service

- a) **Have your power tool serviced by a qualified repair person using only identical replacement parts.** This will ensure that the safety of the power tool is maintained.
- b) **Never service damaged battery packs.** Service of battery packs should only be performed by the manufacturer or authorized service providers.

Additional Chain Saw Safety Warnings

- a) **Keep all parts of the body away from the saw chain when the chain saw is operating. Before you start the chain saw, make sure the saw chain is not contacting anything.** A moment of inattention while operating chain saws may cause entanglement of your clothing or body with the saw chain.
- b) **Always hold the chain saw with your right hand on the rear handle and your left hand on the front handle.** Holding the chain saw with a reversed hand configuration increases the risk of personal injury and should never be done.
- c) **Hold the chain saw by insulated gripping surfaces only, because the saw chain may contact hidden wiring.** Saw chains contacting a "live" wire may make exposed metal parts of the chain saw "live" and could give the operator an electric shock.
- d) **Wear eye protection. Further protective equipment for hearing, head, hands, legs and feet is recommended.** Adequate protective equipment will reduce personal injury from flying debris or accidental contact with the saw chain.
- e) **Do not operate a chain saw in a tree, on a ladder, from a rooftop, or any unstable support.** Operation of a chain saw in this manner could result in serious personal injury.
- f) **Always keep proper footing and operate the chain saw only when standing on fixed, secure and level surface.** Slippery or unstable surfaces may cause a loss of balance or control of the chain saw.
- g) **When cutting a limb that is under tension, be alert for spring back.** When the tension in the wood fibres is released, the spring loaded limb may strike the operator and/or throw the chain saw out of control.
- h) **Use extreme caution when cutting brush and saplings.** The slender material may catch the saw chain and be whipped toward you or pull you off balance.

- i) **Carry the chain saw by the front handle with the chain saw switched off and away from your body. When transporting or storing the chain saw, always fit the guide bar cover.** Proper handling of the chain saw will reduce the likelihood of accidental contact with the moving saw chain.
- j) **Follow instructions for lubricating, chain tensioning and changing the bar and chain.** Improperly tensioned or lubricated chain may either break or increase the chance for kickback.
- k) **Cut wood only. Do not use chain saw for purposes not intended. For example: do not use chain saw for cutting metal, plastic, masonry or non-wood building materials.** Use of the chain saw for operations different than intended could result in a hazardous situation.
- l) **Do not attempt to fell a tree until you have an understanding of the risks and how to avoid them.** Serious injury could occur to the operator or bystanders while felling a tree.

Causes and operator prevention of kickback:

Kickback may occur when the nose or tip of the guide bar touches an object, or when the wood closes in and pinches the saw chain in the cut.

Tip contact in some cases may cause a sudden reverse reaction, kicking the guide bar up and back towards the operator.

Pinching the saw chain along the top of the guide bar may push the guide bar rapidly back towards the operator.

Either of these reactions may cause you to lose control of the saw which could result in serious personal injury. Do not rely exclusively upon the safety devices built into your saw. As a chain saw user, you should take several steps to keep your cutting jobs free from accident or injury.

Kickback is the result of chain saw misuse and/or incorrect operating procedures or conditions and can be avoided by taking proper precautions as given below:

- a) **Maintain a firm grip, with thumbs and fingers encircling the chain saw handles, with both hands on the saw and position your body and arm to allow you to resist kickback forces. Kickback forces can be controlled by the operator, if proper precautions are taken.** Do not let go of the chain saw.
- b) **Do not overreach and do not cut above shoulder height.** This helps prevent unintended tip contact and enables better control of the chain saw in unexpected situations.
- c) **Only use replacement guide bars and saw chains specified by the manufacturer.** Incorrect replacement guide bars and saw chains may cause chain breakage and/or kickback.
- d) **Follow the manufacturer's sharpening and maintenance instructions for the saw chain.** Decreasing the depth gauge height can lead to increased kickback.

General chain saw safety warnings

- a) **Follow all instructions when clearing jammed material, storing or servicing the chain saw. Make sure the switch is off and the battery pack is removed. Unexpected actuation of the chain saw while clearing jammed material or servicing may result in serious personal injury.**

The Following Precautions Should Be Followed to Minimize Kickback:

- Grip saw firmly. Hold the chain saw firmly with both hands when the motor is running. Use a firm grip with thumbs and fingers encircling the chain saw handles.**
Chain saw will pull forward when cutting on the bottom edge of the bar, and push backward when cutting along the top edge of the bar.
- Do not over reach.**
- Keep proper footing and balance at all times.**
- Don't let the nose of the guide bar contact a log, branch, ground or other obstruction.**
- Don't cut above shoulder height.**
- Use devices such as low kickback chain and reduced kickback guide bars that reduce the risks associated with kickback.**
- Only use replacement bars and chains specified by the manufacturer or the equivalent.**
- Never let the moving chain contact any object at the tip of the guide bar.**
- Keep the working area free from obstructions such as other trees, branches, rocks, fences, stumps, etc.**
Eliminate or avoid any obstruction that your saw chain could hit while you are cutting through a particular log or branch.
- Keep your saw chain sharp and properly tensioned. A loose or dull chain can increase the chance of kickback.**
Check tension at regular intervals with the motor stopped and tool unplugged, never with the motor running.
- Begin and continue cutting only with the chain moving at full speed.** If the chain is moving at a slower speed, there is a greater chance for kickback to occur.
- Cut one log at a time.**
- Use extreme caution when re-entering a previous cut.**
Engage bucking spikes into wood and allow chain to reach full speed before proceeding with cut.
- Do not attempt plunge cuts or bore cuts.**
- Watch for shifting logs or other forces that could close a cut and pinch or fall into chain.**

Kickback Safety Features



WARNING: The following features are included on your saw to help reduce the hazard of kickback; however such features will not totally eliminate this dangerous reaction. As a chain saw user do not rely only on safety devices. You must follow all safety precautions, instructions, and

maintenance in this manual to help avoid kickback and other forces which can result in serious injury.

- **Reduced-Kickback Guide Bar**, designed with a small radius tip which reduces the size of the kickback danger zone on bar tip. A reduced - kickback guide bar is one which has been demonstrated to significantly reduce the number and seriousness of kickbacks when tested in accordance with safety requirements for electric chain saws.
- **Low-Kickback Chain**, designed with a contoured depth gauge and guard link which deflect kickback force and allow wood to gradually ride into the cutter. A low-kickback chain is a chain which has met kickback performance requirements of ANSI B175.1–2012.
- Do not operate chain saw while in a tree, on a ladder, on a scaffold, or from any unstable surface.
- Hold tool by insulated gripping surfaces when performing an operation where the cutting tool may contact hidden wiring. Contact with a "live" wire will make exposed metal parts of the tool "live" and shock the operator.
- Do not attempt operations beyond your capacity or experience. Read thoroughly and understand completely all instructions in this manual.
- Before you start chain saw, make sure saw chain is not contacting any object.
- Do not operate a chain saw with one hand! Serious injury to the operator, helpers, or bystanders may result from one handed operation. A chain saw is intended for two-handed use only.
- Keep the handles dry, clean, and free of oil or grease.
- Do not allow dirt, debris, or sawdust to build up on the motor or outside air vents.
- Stop the chain saw before setting it down.
- Do not cut vines and/or small under brush.
- Use extreme caution when cutting small size brush and saplings because slender material may catch the saw chain and be whipped toward you or pull you off balance.

Chain Saw Names and Terms

- **Bucking** - The process of cross cutting a felled tree or log into lengths.
- **Motor Brake (if equipped)** - A device used to stop the saw chain when the trigger is released.
- **Chain Saw Powerhead** - A chain saw without the saw chain and guide bar.
- **Drive Sprocket or Sprocket** - The toothed part that drives the saw chain.
- **Felling** - The process of cutting down a tree.
- **Felling Back Cut** - The final cut in a tree felling operation made on the opposite side of the tree from the notching cut.
- **Front Handle** - The support handle located at or toward the front of the chain saw.
- **Front Hand Guard** - A structural barrier between the front handle of a chain saw and the guide bar, typically located close to the hand position on the front handle.

- **Guide Bar** - A solid railed structure that supports and guides the saw chain.
- **Scabbard/Guide Bar Cover** - Enclosure fitted over guide bar to help prevent tooth contact when saw is not in use.
- **Kickback** - The backward or upward motion, or both of the guide bar occurring when the saw chain near the nose of the top area of the guide bar contacts any object such as a log or branch, or when the wood closes in and pinches the saw chain in the cut.
- **Kickback, Pinch** - The rapid pushback of the saw which can occur when the wood closes in and pinches the moving saw chain in the cut along the top of the guide bar.
- **Kickback, Rotational** - The rapid upward and backward motion of the saw which can occur when the moving saw chain near the upper portion of the tip of the guide bar contacts an object, such as a log or branch.
- **Limbing** - Removing the branches from a fallen tree.
- **Low-Kickback Chain** - A chain that complies with the kickback performance requirements of ANSI B175.1–2012 (when tested on a representative sample of chain saws.)
- **Normal Cutting Position** - Those positions assumed in performing the bucking and felling cuts.
- **Notching Undercut** - A notch cut in a tree that directs the tree's fall.
- **Rear Handle** - The support handle located at or toward the rear of the saw.
- **Reduced Kickback Guide Bar** - A guide bar which has been demonstrated to reduce kickback significantly.
- **Replacement Saw Chain** - A chain that complies with kickback performance requirements of ANSI B175.1–2012 when tested with specific chain saws. It may not meet the ANSI performance requirements when used with other saws.
- **Saw Chain** - A loop of chain having cutting teeth, that cut the wood, and that is driven by the motor and is supported by the guide bar.
- **Ribbed Bumper** - The ribs used when felling or bucking to pivot the saw and maintain position while sawing.
- **Switch** - A device that when operated will complete or interrupt an electrical power circuit to the motor of the chain saw.
- **Switch Linkage** - The mechanism that transmits motion from a trigger to the switch.
- **Switch Lockout** - A movable stop that prevents the unintentional operation of the switch until manually actuated.

Residual Risks

In spite of the application of the relevant safety regulations and the implementation of safety devices, certain residual risks cannot be avoided. These are:

- Impairment of hearing.
- Risk of personal injury due to flying particles.
- Risk of burns due to accessories becoming hot during operation.
- Risk of personal injury due to prolonged use.

SAVE THESE INSTRUCTIONS

Chargers

DeWALT chargers require no adjustment and are designed to be as easy as possible to operate.

Electrical Safety

The electric motor has been designed for one voltage only. Always check that the battery pack voltage corresponds to the voltage on the rating plate. Also make sure that the voltage of your charger corresponds to that of your mains.



Your DeWALT charger is double insulated in accordance with IEC 60335; therefore no earth wire is required.

If the supply cord is damaged, it must be replaced only by DeWALT or an authorised service organisation.

Using an Extension Cable

An extension cord should not be used unless absolutely necessary. Use an approved extension cable suitable for the power input of your charger (see **Technical Data**). The minimum conductor size is 1 mm²; the maximum length is 30 m. When using a cable reel, always unwind the cable completely.

Important Safety Instructions for All Battery Chargers

SAVE THESE INSTRUCTIONS: This manual contains important safety and operating instructions for compatible battery chargers (refer to **Technical Data**).

- Before using charger, read all instructions and cautionary markings on charger, battery pack, and product using battery pack.



WARNING: Shock hazard. Do not allow any liquid to get inside charger. Electric shock may result.



WARNING: We recommend the use of a residual current device with a residual current rating of 30mA or less.



CAUTION: Burn hazard. To reduce the risk of injury, charge only DeWALT rechargeable batteries. Other types of batteries may burst causing personal injury and damage.



CAUTION: Children should be supervised to ensure that they do not play with the appliance.

NOTICE: Under certain conditions, with the charger plugged into the power supply, the exposed charging contacts inside the charger can be shorted by foreign material. Foreign materials of a conductive nature such as, but not limited to, steel wool, aluminum foil or any buildup of metallic particles should be kept away from charger cavities. Always unplug the charger from the power supply when there is no battery pack in the cavity. Unplug charger before attempting to clean.

- **DO NOT attempt to charge the battery pack with any chargers other than the ones in this manual.** The charger and battery pack are specifically designed to work together.
- **These chargers are not intended for any uses other than charging DeWALT rechargeable batteries.** Any other uses may result in risk of fire, electric shock or electrocution.
- **Do not expose charger to rain or snow.**

- **Pull by plug rather than cord when disconnecting charger.** This will reduce risk of damage to electric plug and cord.
- **Make sure that cord is located so that it will not be stepped on, tripped over, or otherwise subjected to damage or stress.**
- **Do not use an extension cord unless it is absolutely necessary.** Use of improper extension cord could result in risk of fire, electric shock, or electrocution.
- **Do not place any object on top of charger or place the charger on a soft surface that might block the ventilation slots and result in excessive internal heat.** Place the charger in a position away from any heat source. The charger is ventilated through slots in the top and the bottom of the housing.
- **Do not operate charger with damaged cord or plug—** have them replaced immediately.
- **Do not operate charger if it has received a sharp blow, been dropped, or otherwise damaged in any way.** Take it to an authorised service centre.
- **Do not disassemble charger; take it to an authorised service centre when service or repair is required.** Incorrect reassembly may result in a risk of electric shock, electrocution or fire.
- *In case of damaged power supply cord, the supply cord must be replaced immediately by the manufacturer, its service agent or similar qualified person to prevent any hazard.*
- **Disconnect the charger from the outlet before attempting any cleaning. This will reduce the risk of electric shock.** Removing the battery pack will not reduce this risk.
- **NEVER** attempt to connect two chargers together.
- **The charger is designed to operate on standard 220-240V household electrical power. Do not attempt to use it on any other voltage.** This does not apply to the vehicular charger.

Charging a Battery (Fig. B)

1. Plug the charger into an appropriate outlet before inserting battery pack.
2. Insert the battery pack **15** into the charger, making sure the battery pack is fully seated in the charger. The red (charging) light will blink repeatedly indicating that the charging process has started.
3. The completion of charge will be indicated by the red light remaining ON continuously. The battery pack is fully charged and may be used at this time or left in the charger. To remove the battery pack from the charger, push the battery release button **16** on the battery pack.

NOTE: To ensure maximum performance and life of lithium-ion battery packs, charge the battery pack fully before first use.

Charger Operation

Refer to the indicators below for the charge status of the battery pack.

Charge Indicators

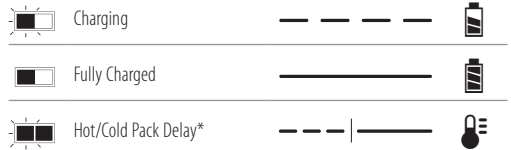

*The red light will continue to blink, but a yellow indicator light will be illuminated during this operation. Once the battery pack has reached an appropriate temperature, the yellow light will turn off and the charger will resume the charging procedure.

The compatible charger(s) will not charge a faulty battery pack. The charger will indicate faulty battery by refusing to light.

NOTE: This could also mean a problem with a charger.

If the charger indicates a problem, take the charger and battery pack to be tested at an authorised service centre.

Hot/Cold Pack Delay

When the charger detects a battery pack that is too hot or too cold, it automatically starts a Hot/Cold Pack Delay, suspending charging until the battery pack has reached an appropriate temperature. The charger then automatically switches to the pack charging mode. This feature ensures maximum battery pack life.

A cold battery pack will charge at a slower rate than a warm battery pack. The battery pack will charge at that slower rate throughout the entire charging cycle and will not return to maximum charge rate even if the battery pack warms.

The DCB118 charger is equipped with an internal fan designed to cool the battery pack. The fan will turn on automatically when the battery pack needs to be cooled. Never operate the charger if the fan does not operate properly or if ventilation slots are blocked. Do not permit foreign objects to enter the interior of the charger.

Electronic Protection System

XR Li-Ion tools are designed with an Electronic Protection System that will protect the battery pack against overloading, overheating or deep discharge.

The tool will automatically turn off if the Electronic Protection System engages. If this occurs, place the lithium-ion battery pack on the charger until it is fully charged.

Wall Mounting

These chargers are designed to be wall mountable or to sit upright on a table or work surface. If wall mounting, locate the charger within reach of an electrical outlet, and away from a corner or other obstructions which may impede air flow. Use the back of the charger as a template for the location of the mounting screws on the wall. Mount the charger securely using drywall screws (purchased separately) at least 25.4 mm long with a screw head diameter of 7–9 mm, screwed into wood to an optimal depth leaving approximately 5.5 mm of the screw exposed. Align the slots on the back of the charger with the exposed screws and fully engage them in the slots.

Charger Cleaning Instructions



WARNING: Shock hazard. Disconnect the charger from the AC outlet before cleaning. Dirt and grease may be removed from the exterior of the charger using a cloth or soft non-metallic brush. Do not use water or any cleaning solutions. Never let any liquid get inside the tool; never immerse any part of the tool into a liquid.

Battery Packs

Important Safety Instructions for All Battery Packs

When ordering replacement battery packs, be sure to include catalogue number and voltage.

The battery pack is not fully charged out of the carton. Before using the battery pack and charger, read the safety instructions below. Then follow charging procedures outlined.

READ ALL INSTRUCTIONS

- **Do not charge or use battery in explosive atmospheres, such as in the presence of flammable liquids, gases or dust.** Inserting or removing the battery from the charger may ignite the dust or fumes.
- **Never force battery pack into charger. Do not modify battery pack in any way to fit into a non-compatible charger as battery pack may rupture causing serious personal injury.**
- Charge the battery packs only in DEWALT chargers.
- **DO NOT splash or immerse in water or other liquids.**
- **Do not store or use the tool and battery pack in locations where the temperature may fall below 4 °C (39.2 °F) (such as outside sheds or metal buildings in winter), or reach or exceed 40 °C (104 °F) (such as outside sheds or metal buildings in summer).**
- **Do not incinerate the battery pack even if it is severely damaged or is completely worn out.** The battery pack can explode in a fire. Toxic fumes and materials are created when lithium-ion battery packs are burned.
- **If battery contents come into contact with the skin, immediately wash area with mild soap and water.** If battery liquid gets into the eye, rinse water over the open eye for 15 minutes or until irritation ceases. If medical attention is needed, the battery electrolyte is composed of a mixture of liquid organic carbonates and lithium salts.
- **Contents of opened battery cells may cause respiratory irritation.** Provide fresh air. If symptoms persists, seek medical attention.



WARNING: Burn hazard. Battery liquid may be flammable if exposed to spark or flame.



WARNING: Never attempt to open the battery pack for any reason. If battery pack case is cracked or damaged, do not insert into charger. Do not crush, drop or damage battery pack. Do not use a battery pack or charger that has received a sharp blow, been dropped, run over or damaged in any way (i.e., pierced with a nail, hit with a hammer, stepped on). Electric shock or electrocution

may result. Damaged battery packs should be returned to service centre for recycling.



WARNING: Fire hazard. Do not store or carry the battery pack so that metal objects can contact exposed battery terminals. For example, do not place the battery pack in aprons, pockets, tool boxes, product kit boxes, drawers, etc., with loose nails, screws, keys, etc.



CAUTION: When not in use, place tool on its side on a stable surface where it will not cause a tripping or falling hazard. Some tools with large battery packs will stand upright on the battery pack but may be easily knocked over.

Transportation



WARNING: Fire hazard. Transporting batteries can possibly cause fire if the battery terminals inadvertently come in contact with conductive materials. When transporting batteries, make sure that the battery terminals are protected and well insulated from materials that could contact them and cause a short circuit. **NOTE:** Lithium-ion batteries should not be put in checked baggage.

DEWALT batteries comply with all applicable shipping regulations as prescribed by industry and legal standards which include UN Recommendations on the Transport of Dangerous Goods; International Air Transport Association (IATA) Dangerous Goods Regulations, International Maritime Dangerous Goods (IMDG) Regulations, and the European Agreement Concerning The International Carriage of Dangerous Goods by Road (ADR). Lithium-ion cells and batteries have been tested to section 38.3 of the UN Recommendations on the Transport of Dangerous Goods Manual of Tests and Criteria.

In most instances, shipping a DEWALT battery pack will be excepted from being classified as a fully regulated Class 9 Hazardous Material. In general, only shipments containing a lithium-ion battery with an energy rating greater than 100 Watt Hours (Wh) will require being shipped as fully regulated Class 9. All lithium-ion batteries have the Watt Hour rating marked on the pack. Furthermore, due to regulation complexities, DEWALT does not recommend air shipping lithium-ion battery packs alone regardless of Watt Hour rating. Shipments of tools with batteries (combo kits) can be air shipped as excepted if the Watt Hour rating of the battery pack is no greater than 100 Wh. Regardless of whether a shipment is considered excepted or fully regulated, it is the shipper's responsibility to consult the latest regulations for packaging, labeling/marketing and documentation requirements.

The information provided in this section of the manual is provided in good faith and believed to be accurate at the time the document was created. However, no warranty, expressed or implied, is given. It is the buyer's responsibility to ensure that its activities comply with the applicable regulations.

Transporting the FLEXVOLT™ Battery

The DEWALT FLEXVOLT™ battery has two modes: **Use** and **Transport**.

Use Mode: When the FLEXVOLT™ battery stands alone or is in a DEWALT 18V (20V Max) product, it will operate as an 18V (20V Max) battery. When the FLEXVOLT™ battery is in a 54V (60V Max) or a 108V (120V Max) (two 54V (60V Max) batteries) product, it will operate as a 54V (60V Max) battery.

Transport Mode: When the cap is attached to the FLEXVOLT™ battery, the battery is in Transport mode. Keep the cap for shipping.

When in Transport mode, strings of cells are electrically disconnected within the pack resulting in 3 batteries with a lower Watt hour (Wh) rating as compared to 1 battery with a higher Watt hour rating. This increased quantity of 3 batteries with the lower Watt hour rating can exempt the pack from certain shipping regulations that are imposed upon the higher Watt hour batteries.

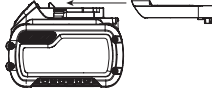

For example, the Transport Wh rating might indicate 3 x 36 Wh, meaning 3 batteries of 36 Wh each. The Use Wh rating might indicate 108 Wh (1 battery implied).

Example of Use and Transport Label Marking



Storage Recommendations

1. The best storage place is one that is cool and dry away from direct sunlight and excess heat or cold. For optimum battery performance and life, store battery packs at room temperature when not in use.
2. For long storage, it is recommended to store a fully charged battery pack in a cool, dry place out of the charger for optimal results.

NOTE: Battery packs should not be stored completely depleted of charge. The battery pack will need to be recharged before use.

Labels on Charger and Battery Pack

In addition to the pictographs used in this manual, the labels on the charger and the battery pack may show the following pictographs:



Read instruction manual before use.



See **Technical Data** for charging time.



Do not probe with conductive objects.



Do not charge damaged battery packs.



Do not expose to water.



Have defective cords replaced immediately



Charge only between 4 °C and 40 °C.



Only for indoor use.



Discard the battery pack with due care for the environment.



Charge battery packs only with designated DEWALT chargers. Charging battery packs other than the designated DEWALT batteries with a DEWALT charger may make them burst or lead to other dangerous situations.



Do not incinerate the battery pack.



USE (without transport cap). Example: Wh rating indicates 108 Wh (1 battery with 108 Wh).



TRANSPORT (with built-in transport cap). Example: Wh rating indicates 3 x 36 Wh (3 batteries of 36 Wh).

Battery Type

The following tools operate on a 54 volt (60V Max) battery pack: DCMCS574, DCMCS575

These battery packs may be used: DCB546, DCB547, DCB548, DCB549, DCB606, DCB609, DCB612, DCB615. Refer to **Technical Data** for more information.

Package Contents

The DCMCS574 package contains:

- 1 Chainsaw
- 1 Scabbard
- 1 Bar 45 cm
- 1 Chain 45 cm
- 1 Wrench
- 1 Instruction manual

The DCMCS575 package contains:

- 1 Chainsaw
- 1 Scabbard
- 1 Bar 50 cm
- 1 Chain 50 cm
- 1 Wrench
- 1 Instruction manual

NOTE: Battery packs, chargers and kitboxes are not included with N models. Battery packs and chargers are not included with NT models. B models include Bluetooth® battery packs.

NOTE: The Bluetooth® word mark and logos are registered trademarks owned by the Bluetooth®, SIG, Inc. and any use of such marks by DEWALT is under license. Other trademarks and trade names are those of their respective owners.

- Check for damage to the tool, parts or accessories which may have occurred during transport.
- Take the time to thoroughly read and understand this manual prior to operation.

Markings on Tool

The following pictograms are shown on the tool:



Read instruction manual before use.



Wear ear protection.



Wear eye protection



Wear head protection.



Wear gloves.



Wear proper foot protection.



Do not expose the tool to rain or high humidity or leave outdoors while it is raining.



Contact of the guide bar tip with any object should be avoided.



Rotational direction of the saw chain.



Always use two hands when operating the chainsaw.



Switch the tool off. Before performing any maintenance on the tool, remove the battery from the tool.

Date Code Position (Fig. A)

The date code **18**, which also includes the year of manufacture, is printed into the housing.

Example:

2022 XX XX

Year and Week of Manufacture

Description (Fig. A)



WARNING: Never modify the power tool or any part of it. Damage or personal injury could result.

- 1 Trigger
- 2 Lock-off lever
- 3 Chain brake / front hand guard
- 4 Guide bar
- 5 Saw chain
- 6 Sprocket cover
- 7 Bar lock nuts
- 8 Chain tensioning screw
- 9 Oil level indicator
- 10 Oil cap
- 11 Guide bar scabbard
- 12 Rear handle
- 13 Front handle

- 14 Battery housing
- 15 Battery Pack
- 16 Battery release button
- 17 Wrench
- 18 Date code

Intended Use

The DCMCS574 chainsaw is designed for cutting logs up to 40 cm in diameter.

The DCMCS575 chainsaw is designed for cutting logs up to 45 cm in diameter.

DO NOT use under wet conditions or in presence of flammable liquids or gases.

These chainsaws are professional power tools.

DO NOT let children come into contact with the tool. Supervision is required when inexperienced operators use this tool.

- **Young children and the infirm.** This appliance is not intended for use by young children or infirm persons without supervision.
- This product is not intended for use by persons (including children) suffering from diminished physical, sensory or mental abilities; lack of experience, knowledge or skills unless they are supervised by a person responsible for their safety. Children should never be left alone with this product.

ASSEMBLY AND ADJUSTMENTS



WARNING: To reduce the risk of serious personal injury, turn tool off and disconnect battery pack before making any adjustments or removing/installing attachments or accessories. An accidental start-up can cause injury.



WARNING: Use only DEWALT battery packs and chargers.

Inserting and Removing the Battery Pack from the Tool (Fig. D)

NOTE: Make sure your battery pack **15** is fully charged.

To Install the Battery Pack into the Tool

1. Align the battery pack **15** with the rails inside the tool's battery housing **14** (Fig. D).
2. Slide it into the battery housing until the battery pack is firmly seated in the tool and ensure that you hear the lock snap into place.

To Remove the Battery Pack from the Tool

1. Press the battery release button **16** and firmly pull the battery pack out of the tool.
2. Insert battery pack into the charger as described in the charger section of this manual.

Fuel Gauge Battery Packs (Fig. C)

Some DEWALT battery packs include a fuel gauge which consists of three green LED lights that indicate the level of charge remaining in the battery pack.

To actuate the fuel gauge, press and hold the fuel gauge button **19**. A combination of the three green LED lights will illuminate designating the level of charge left. When the level of charge in the battery is below the usable limit, the fuel gauge will not illuminate and the battery will need to be recharged.

NOTE: The fuel gauge is only an indication of the charge left on the battery pack. It does not indicate tool functionality and is subject to variation based on product components, temperature and end-user application.

Installing the Guide Bar and Saw Chain

(Fig. A, E–G)



CAUTION: Sharp chain. Always wear protective gloves when handling the chain. The chain is sharp and can cut you when it is not running.



WARNING: Sharp moving chain. To prevent accidental operation, ensure the battery is removed from the tool before performing the following operations. Failure to do this could result in serious personal injury.

If the saw chain **5** and guide bar **4** are packed separately in the carton, the chain has to be attached to the bar, and both must be attached to the body of the tool.

1. Place the saw on a flat, firm surface.
2. Rotate the bar lock nuts **7** counterclockwise with the wrench **17** provided.
3. Remove sprocket cover **6**, and bar lock nuts **7**.
4. Wearing protective gloves, grasp the saw chain **5** and wrap it around the guide bar **4**, ensuring the teeth are facing the correct direction.
5. Ensure the chain is properly set in the slot around the entire guide bar.
6. Place the saw chain around the sprocket **20**. While lining up the slot on the guide bar with chain tensioning pin **21**, and the bolts **22**, on the base of the tool as shown in Fig. E.
7. Once in place, hold the bar still, replace sprocket cover **6**. Make sure bolt holes on the cover line up with the bolts **22**, on the main housing.
8. Install the bar lock nuts **7** and rotate clockwise with the wrench **17** provided until snug, then loosen the nut(s) one full turn, so that the saw chain can be properly tensioned.
9. Using the flat screwdriver end of the wrench **17** rotate the chain tensioning screw **8** clockwise to increase tension. Make sure the saw chain **5** is snug around the guide bar **4** as shown in Fig. F and Fig. G then tighten the bar lock nut(s) **7** until snug.
10. Follow the instructions in the section **Adjusting Chain Tension**.

Adjusting Chain Tension (Fig. A, E–G)

NOTE: Saw chain tension should be adjusted regularly before each use.

1. With the saw still on a firm surface check the saw chain **5** tension. The tension is correct when the saw chain snaps back after being pulled 6 mm away from the guide bar **4** with light force from the middle finger and thumb as shown

in Fig. F. There should be no “sag” between the guide bar and the saw chain on the underside as shown in Fig. G.

2. To adjust saw chain tension, loosen bar lock nuts **7**.
3. Rotate the chain tension screw **8** located on the sprocket cover using the flat screwdriver end of the wrench **17**.
4. Check saw chain tension, adjust if needed.
5. Do not over-tension the saw chain as this will lead to excessive wear and will reduce the life of the guide bar and saw chain.
6. Once saw chain tension is correct, tighten bar lock nuts **7** until tight using 6 ft. lbs. (8 Nm) of torque.
7. A new chain stretches slightly during the first few hours of use. It is important to check the tension frequently (after removing the battery pack) during the first 2 hours of use.

Replacing the Saw Chain (Fig. A, E, H)



CAUTION: Sharp chain. Always wear protective gloves when handling the chain. The chain is sharp and can cut you when it is not running.



WARNING: Sharp moving chain. To prevent accidental operation, ensure the battery is removed from the tool unplugged before performing the following operations. Failure to do this could result in serious personal injury.

1. To remove the saw chain **5**, place the saw on a flat, firm surface.
2. Remove sprocket cover **6** as described in **Installing the Guide Bar and Saw Chain** section.
3. Rotate the chain tension screw **8** using the flat screwdriver end of the wrench **17**. Turning the screw counterclockwise allows the guide bar **4** to recede and reduces the tension on the chain so that it may be removed.
4. Wearing protective gloves, grasp the saw chain and lift the worn saw chain out of the groove in the guide bar.
5. Flip guide bar over every time you replace the chain to ensure even wear.
6. Place the new chain in the slot of the guide bar, making sure the saw teeth are facing the correct direction by matching the arrow and graphic of the saw chain on the sprocket cover **6** shown in Fig. H.
7. Follow instructions for **Installing the Guide Bar and Saw Chain**.

Replacement chain and bar are available from your nearest authorized service center.

- The DCMCS574 chain saw requires a replacement 45 cm chain DWO1DT618 and a replacement 45 cm bar DWZCSB18.
- The DCMCS575 chain saw requires a replacement 50 cm chain DWO1DT620 and a replacement 50 cm bar DWZCSB20.

Saw Chain and Guide Bar Oiling (Fig. A)

Auto Oiling System

This chainsaw is equipped with an auto oiling system that keeps the saw chain and guide bar constantly lubricated. The oil level indicator **9** shows the level of the oil in the chainsaw. If the oil level is less than a quarter full, remove the battery from the

chainsaw and refill with the correct type of oil. Always empty oil tank when finished cutting.

NOTE: Use a high quality bar and chain oil for proper saw chain and bar lubrication. As a temporary substitute, a non-detergent SAE30 weight motor oil can be used. The use of a vegetable based bar and chain oil is recommended when pruning trees. Mineral oil is not recommended because it may harm trees. Never use waste oil or very thick oil. These may damage your chain saw.

Filling the Oil Reservoir

1. Unscrew counterclockwise and then remove the oil cap **10**. Fill the reservoir with the recommended bar and chain oil until the oil level has reached the top of the oil level indicator **9**.
2. Refit the oil cap and tighten clockwise.
3. Periodically switch the chainsaw off and check the oil level indicator to ensure the bar and chain are being properly oiled.

Transporting Chain Saw (Fig. A)

- Always remove the battery from the tool and cover the guide bar **4** with the scabbard **11** when transporting the saw.

OPERATION

Instructions for Use



WARNING: Always observe the safety instructions and applicable regulations.



WARNING: To reduce the risk of serious personal injury, turn tool off and disconnect battery pack before making any adjustments or removing/installing attachments or accessories. An accidental start-up can cause injury.

•Proper Hand Position (Fig. I)



WARNING: To reduce the risk of serious personal injury, ALWAYS use proper hand position as shown.



WARNING: To reduce the risk of serious personal injury, ALWAYS hold securely in anticipation of a sudden reaction.

Proper hand position requires the left hand on the front handle **13**, with the right hand on the rear handle **12**.

Operating the Chain Saw (Fig. A, I, K)



WARNING: Read and understand all instructions. Failure to follow all instructions listed below may result in electric shock, fire and/or serious personal injury.

- Guard Against Kickback which can result in severe injury or death. See **General Power Tool Safety Warnings and General Chainsaw Safety Warnings, and Causes and Operator Prevention of Kickback and Kickback Safety Features, to avoid the risk of kickback.**

- Do not overreach. Do not cut above chest height. Make sure your footing is firm. Keep feet apart. Divide your weight evenly on both feet.
- Use a firm grip with your left hand on the front handle **13** and your right hand on the rear handle **12** so that your body is to the left of the guide bar.
- Do not hold chain saw by chain brake/front hand guard **3**. Keep elbow of left arm locked so that left arm is straight to withstand a kickback.



WARNING: Never use a cross-handed grip (left hand on the rear handle and right hand on the front handle).



WARNING: Never allow any part of your body to be in line with the guide bar **4** when operating the chain saw.

- Never operate while in a tree, in any awkward position or on a ladder or other unstable surface. You may lose control of saw causing severe injury.
- Keep the chain saw running at full speed the entire time you are cutting.
- Allow the saw chain to cut for you. Exert only light pressure. Do not put pressure on chain saw at end of cut.



WARNING: When not in use always have the chain brake engaged and battery removed.

Setting the Chain Brake (Fig. K)

Your chain saw is equipped with a chain braking system which will stop the chain quickly in case of kickback.

1. Remove the battery from the tool.
2. To engage the chain brake, push the chain brake/front hand guard **3** forward until it clicks into place.
3. Pull the chain brake/front hand guard **3** towards the front handle **13** into the "set" position as shown in Fig. K.
4. The tool is now ready to use.

NOTE: In the event of kickback, your left hand will come in contact with the front guard, pushing it forward, toward the workpiece. This will stop the tool.

Testing the Chain Brake (Fig. A, K)

Test the chain brake before every use to make sure it operates correctly.

1. Place the tool on a flat, firm surface. Make sure the saw chain **5** is clear of the ground.
2. Grip the tool firmly with both hands and turn the chain saw on.
3. Rotate your left hand forward around the front handle **13** so the back of your hand comes in contact with the chain brake/front hand guard **3** and push it forward, toward the workpiece. The saw chain should stop immediately.

NOTE: If saw does not stop immediately, stop use of tool and bring it to an authorized service center nearest you.



WARNING: Make sure to set chain brake before cutting.

ON/OFF Switch (Fig. J)

Always be sure of your footing and grip the chain saw firmly with both hands with the thumb and fingers encircling both handles.

1. To turn the unit on, push down on the the lock off lever ②, shown in Fig. J, and squeeze the trigger switch ①. Once the unit is running, you may release the lock off lever.
2. In order to keep the unit running you must continue to squeeze the trigger. To turn the unit off, release the trigger.

NOTE: If too much force is applied while making a cut the saw will turn off. To restart saw, you must release the trigger switch ① before the saw will restart. Begin your cut again this time with less force. Allow the saw to cut at its own pace.

WARNING: *Never attempt to lock a switch in the ON position.*

Common Cutting Techniques

Felling

The process of cutting down a tree. Do not fell trees in high wind conditions.

WARNING: *Felling can result in injury. It should only be performed by a trained person.*

- A retreat path should be planned and cleared as necessary before cuts are started. The retreat path should extend back and diagonally to the rear of the expected line of fall as shown below.

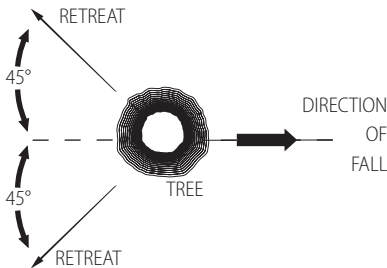

- Before felling is started, consider the natural lean of the tree, the location of larger branches and the wind direction to judge which way the tree will fall. Have wedges (wood, plastic or aluminum) and a heavy mallet handy. Remove dirt, stones, loose bark, nails, staples, and wire from the tree where the felling cuts are to be made.
- **Notching Undercut** - Make the notch 1/3 of the diameter of the tree, perpendicular to the direction of the fall. Make the lower horizontal notching cut first. This will help to avoid pinching of either the saw chain or the guide bar when the second notch cut is being made as shown below.
- **Felling Back Cut** - Make the felling back cut at least 51 mm higher than the horizontal notching cut. Keep the felling back cut parallel to the horizontal notching cut. Make the felling back cut so enough wood is left to act as a hinge. The hinge wood keeps the tree from twisting and falling

in the wrong direction. Do not cut through the hinge as shown below.

- As the felling cut gets close to the hinge the tree should begin to fall. If there is any chance that the tree may not fall in the desired direction or it may rock back and bind the saw chain, stop cutting before the felling cut is complete and use wedges to open the cut and drop the tree along the desired line of fall. When the tree begins to fall remove the chainsaw from the cut, stop the motor, put the chainsaw down, then use the retreat path planned. Be alert for overhead limbs falling and watch your footing.

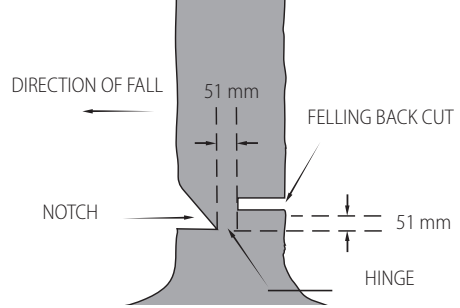

Limbing

Removing the branches from a fallen tree. When limbing, leave larger lower limbs to support the log off the ground. Remove the small limbs in one cut. Branches under tension should be cut from the bottom of the branch towards the top to avoid binding the chainsaw as shown below. Trim limbs from opposite side keeping tree stem between you and saw. Never make cuts with saw between your legs or straddle the limb to be cut.

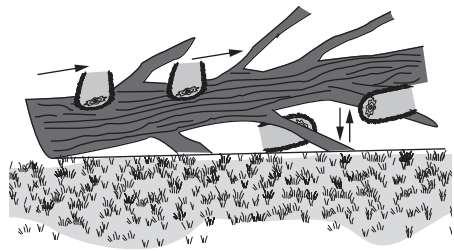

Bucking

WARNING: *Recommend that first time users should practice cutting on a saw horse.*

Cutting a felled tree or log into lengths. How you should cut depends on how the log is supported. Use a saw horse whenever possible as shown below.

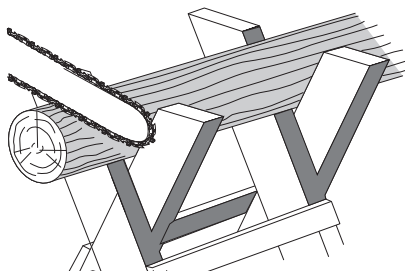

1. Always start a cut with the saw chain running at full speed.
2. Place the bottom spike **23** of the chainsaw behind the area of the initial cut as shown below.
3. Turn the chainsaw on then rotate the saw chain and bar down into the tree, using the spike as a hinge.
4. Once the chainsaw gets to a 45° angle, level the chainsaw again and repeat steps until you cut fully through.
5. When the tree is supported along its entire length, make a cut from the top (overbuck) and avoid cutting the earth as this will dull your saw quickly.

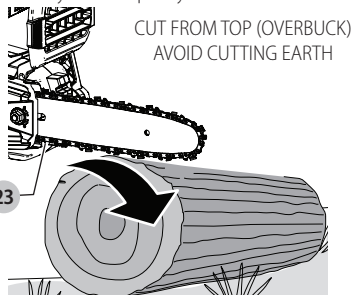

- When supported at one end first, cut 1/3 the diameter from the underside (underbuck). Then make the finishing cut by overbucking to meet the first cut as shown below.

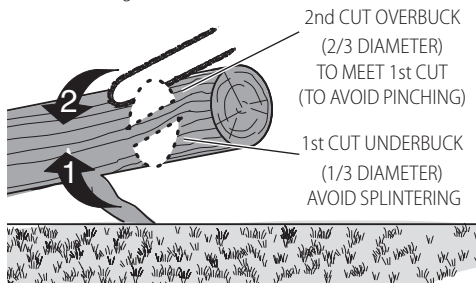

- When supported at both ends. First, cut 1/3 down from the top overbuck. Then make the finished cut by underbucking the lower 2/3 to meet the first cut as shown below.

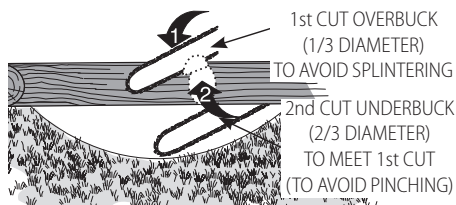

- When on a slope always stand on the uphill side of the log. When “cutting through”, to maintain complete control reduce the cutting pressure near the end of the cut without relaxing your grip on the chain saw handles. Don't let the chain contact the ground. After completing the cut, wait for the saw chain to stop before you move the chain saw. Always stop the motor before moving from cut to cut.

MAINTENANCE

Your power tool has been designed to operate over a long period of time with a minimum of maintenance. Continuous satisfactory operation depends upon proper tool care and regular cleaning.

⚠ WARNING: To reduce the risk of serious personal injury, turn tool off and disconnect battery pack before making any adjustments or removing/installing attachments or accessories. An accidental start-up can cause injury.

The charger and battery pack are not serviceable.

Saw Chain Sharpness

⚠ CAUTION: Sharp chain. Always wear protective gloves when handling the chain. The chain is sharp and can cut you when it is not running.

IMPORTANT: The chain cutters will dull immediately if they touch the ground, stones, masonry or a nail while cutting. To get the best possible performance from your chain saw it is important to keep the teeth of the saw chain sharp. Chain sharpening services are available from your nearest DEWALT service center.

NOTE: Each time the saw chain is sharpened, it loses some of the reduced kickback qualities and extra caution should be used. It is recommended that a saw chain be sharpened no more than four times.



Lubrication

Your power tool requires no additional lubrication.



Cleaning

⚠ WARNING: Blow dirt and dust out of the main housing with dry air as often as dirt is seen collecting in and around the air vents. Wear approved eye protection and approved dust mask when performing this procedure.



WARNING: *Never use solvents or other harsh chemicals for cleaning the non-metallic parts of the tool. These chemicals may weaken the materials used in these parts. Use a cloth dampened only with water and mild soap. Never let any liquid get inside the tool; never immerse any part of the tool into a liquid.*

Optional Accessories



WARNING: *Since accessories, other than those offered by PROTODEWALT, have not been tested with this product, use of such accessories with this tool could be hazardous. To reduce the risk of injury, only PROTODEWALT recommended accessories should be used with this product.*

Consult your dealer for further information on the appropriate accessories.

Protecting the Environment



Separate collection. Products and batteries marked with this symbol must not be disposed of with normal household waste.



Products and batteries contain materials that can be recovered or recycled reducing the demand for raw materials. Please recycle electrical products and batteries according to local provisions. Further information is available at www.2helpU.com.

Rechargeable Battery Pack

This long life battery pack must be recharged when it fails to produce sufficient power on jobs which were easily done before. At the end of its technical life, discard it with due care for our environment:

- Run the battery pack down completely, then remove it from the tool.
- Li-Ion cells are recyclable. Take them to your dealer or a local recycling station. The collected battery packs will be recycled or disposed of properly.

After Service and Repair

DEWALT service centers are staffed with trained personnel to provide customers with efficient and reliable product service. We do not take any responsibility when you have repaired in unauthorized service center. You can refer to the leaflet of CONTACT CENTER LOCATOR in product package and contact us through hotline, website or social media to find the nearest DEWALT service center around you.

60V锂电无刷链锯

DCMCS574, DCMCS575

恭喜!

感谢您选购DeWALT工具。凭借多年的产品开发和创新能力，DeWALT已经成为专业电动工具用户最可靠的合作伙伴之一。

技术数据

		DCMCS574	DCMCS575
电压	V _{DC}	54 (最大60)	54 (最大60)
电池类型		锂离子	锂离子
导板长度	cm	45	50
链条速度	m/s	13.5	13.5
最大切割长度	cm	40	45
油壶容量	ml	115	115
重量 (不含电池包)	kg	5	5.7

电池				充电器/充电时间 (分钟)						
型号	V _{DC}	电池容量 (Ah)	重量 (kg)	DCB104	DCB107	DCB112	DCB115	DCB117 DCB1112	DCB118	DCB132
DCB546/DCB606 18/54 (最大20/60)		6.0/2.0	1.08	60	270	170	90	40	60	90
DCB547/DCB609 18/54 (最大20/60)		9.0/3.0	1.46	75*	420	270	135*	60	75*	135*
DCB548/DCB612 18/54 (最大20/60)		12.0/4.0	1.46	120	540	350	180	80	120	180
DCB549/DCB615 18/54 (最大20/60)		15.0/5.0	2.12	125	730	450	230	90	125	230

*日期码201811475B或以后

**日期码 201536 或以后



警告：为降低伤害风险，请阅读使用手册。

定义:安全指南

下列定义描述了各标志术语的严重程度。请仔细阅读本产品手册，并注意这些标志。



危险：表示存在紧急危险情况，如果不加以避免，将导致死亡或严重伤害。



警告：表示存在潜在的危险情况，如果不加以避免，可能导致死亡或严重伤害。



小心：表示存在潜在危险情况，如果不加以避免，可能导致轻度或中度伤害。

注意：表示存在不涉及人身伤害的情况，如果不加以避免，可能导致财产损失。



表示存在触电风险。



表示存在火灾风险。

电动工具通用安全警告



警告：请阅读本电动工具随附的所有安全警告、说明、图示和规定。未能遵照以下所列说明会导致电击、火灾和/或严重伤害。

保存所有警告和说明书以备查阅。

警告中的术语“电动工具”指市电驱动 (有线) 电动工具或电池驱动 (无线) 电动工具。

1) 工作场地的安全

- 保持工作场地清洁和明亮。杂乱和黑暗的场地会引发事故。
- 不要在易爆环境，如有易燃液体、气体或粉尘的环境下操作电动工具。电动工具产生的火花会点燃粉尘或气体。
- 操作电动工具时，远离儿童和旁观者。注意力不集中会使你失去对工具的控制。

2) 电气安全

- 电动工具插头必须与插座相配。绝不能以任何方式改装插头。需接地的电动工具不能使用任何转换插头。未经改装的插头和相配的插座将降低电击风险。
- 避免人体接触接地表面，如管道、散热片和冰箱。如果你身体接触接地表面会增加电击风险。
- 不得将电动工具暴露在雨中或潮湿环境中。水进入电动工具将增加电击风险。
- 不得滥用软线。绝不能用软线搬运、拉动电动工具或拔出其插头。使软线远离热源、油、锐边或运动部件。受损或缠绕的软线会增加电击风险。

- e) 当在户外使用电动工具时,使用适合户外使用的延长线。适合户外使用的电线将降低电击风险。
- f) 如果无法避免在潮湿环境中操作电动工具,应使用带有剩余电流装置(RCD)保护的电源。RCD的使用可降低电击风险。

3) 人身安全

- a) 保持警觉,当操作电动工具时关注所从事的操作并保持清醒。当你感到疲倦,或在有药物、酒精或治疗反应时,不要操作电动工具。在操作电动工具时瞬间的疏忽会导致严重人身伤害。
- b) 使用个人防护设备。始终佩戴护目镜。防护装置,诸如适当条件下使用防尘面具、防滑安全鞋、安全帽、听力防护等装置能减少人身伤害。
- c) 防止意外启动。在连接电源和/或电池包、拿起或搬运工具前确保开关处于关断位置。手指放在开关上搬运工具或开关处于接通时通电会导致危险。
- d) 在电动工具接通之前,拿掉所有调节钥匙或扳手。遗留在电动工具旋转零件上的扳手或钥匙会导致人身伤害。
- e) 请勿过分伸展。时刻注意立足点和身体平衡。这样能在意外情况下能更好地控制住电动工具。
- f) 着装适当。不要穿宽松衣服或佩戴饰品。让你的头发和衣服远离运动部件。宽松衣服、配饰或长发可能会卷入运动部件。
- g) 如果提供了与排屑、集尘设备连接用的装置,要确保其连接完好且使用得当。使用集尘装置可降低尘屑引起的危险。
- h) 不要因为频繁使用工具而产生的熟悉感而掉以轻心,忽视工具的安全准则。某个粗心的动作可能在瞬间导致严重的伤害。

4) 电动工具使用和注意事项

- a) 切勿强制使用电动工具。根据用途使用合适的电动工具。选用合适的按照额定值设计的电动工具会使你工作更有效、更安全。
- b) 如果开关不能接通或关断电源,则不能使用该电动工具。不能通过开关来控制的电动工具是危险的且必须进行修理。
- c) 在进行任何调节、更换附件或贮存电动工具之前,必须从电源上拔掉插头和/或卸下电池包(如可拆卸)。这种防护性的安全措施降低了电动工具意外启动的风险。
- d) 将闲置不用的电动工具贮存儿童所及范围之外,并且不允许不熟悉电动工具和不了解这些说明的人操作电动工具。电动工具在未经培训的使用者手中是危险的。
- e) 维护电动工具及其附件。检查运动部件是否调整到位或卡住,检查零件破损情况和影响电动工具运行的其他状况。如有损坏,应在使用前修理好电动工具。许多事故是由维护不良的电动工具引发的。
- f) 保持切削刀具锋利和清洁。维护良好地有锋利切削刃的刀具不易卡住而且容易控制。
- g) 按照使用说明书,并考虑作业条件和要进行的作业来选择电动工具、附件和工具的刀头等。将电

动工具用于那些与其用途不符的操作可能会导致危险情况。

- h) 保持手柄和握持表面干燥、清洁,不得沾有油脂。在意外的情况下,湿滑的手柄不能保证握持的安全和对工具的控制。

5) 电池式工具使用和注意事项

- a) 仅使用生产者规定的充电器充电。将适用于某种电池包的充电器用到其他电池包时可能会发生着火危险。
- b) 仅使用配有专用电池包的电动工具。使用其他电池包可能会产生伤害和着火危险。
- c) 当电池包不用时,将它远离其他金属物体,例如回形针、硬币、钥匙、钉子、螺钉或其他小金属物体,以防电池包一端与另一端连接。电池包端部短路会引起燃烧或着火。
- d) 在滥用条件下,液体可能会从电池包中溅出,应避免接触。如果意外碰到液体,用水冲洗。如果液体碰到了眼睛,还应寻求医疗帮助。从电池中溅出的液体可能会发生腐蚀或燃烧。
- e) 不要使用损坏或改装过的电池包或工具。损坏或改装过的电池包可能呈现无法预测的结果,导致着火、爆炸或伤害。
- f) 不要将电池包暴露于火或高温中。电池包暴露于火或高于130°C的高温中可能导致爆炸。
- g) 请遵循所有充电说明,请勿在说明中规定的温度范围以外的环境对电池包或工具充电。不当或在指定范围以外的温度下充电,可能导致电池损坏并增加火灾风险。

6) 维修

- a) 让专业维修人员使用相同的备件维修电动工具。这将保证所维修的电动工具的安全。
- b) 切勿维修损坏的电池包。电池包仅能由生产者或其授权的维修服务商进行维修。

其他链锯安全警告

- a) 操作链锯时,让身体所有部位远离锯链。在启动链锯之前,确保锯链没有接触其他物件。操作链锯时不小心,就会将你衣服或身体缠入锯链。
- b) 始终用右手握持链锯的后手柄,左手握持前手柄。反手握持链锯,会增加人身伤害的风险,应绝对禁止。注:对导板设计在左侧的链锯,所述的“右手”和“左手”位置应相反。
- c) 佩戴安全眼镜和听力保护器。建议进一步提供头、手、腿和脚的防护装备。充分的防护衣可降低飞屑或意外触碰锯链导致的人身伤害。
- d) 不要站在树上操作链锯。上树操作链锯会造成人身伤害。
- e) 始终保持良好的立足之地,并只有站在牢固安全和平坦地面上时才操作链锯。易滑或不稳的地面,诸如梯子会引起失去平衡或链锯操作失控。
- f) 锯割处于拉紧状态的枝杈时要提防反弹。当木材纤维的拉力一旦释放,有弹性的树杈可能会击到操作者和/或致使链锯失控。
- g) 锯割灌木和小树苗时要特别当心。细条可能会夹住锯链并向操作者打来或拉操作者失去平衡。

- h) 用前手柄携带关断的链锯并使链锯远离你的身体。当运输或储存链锯时应始终装有导板护罩。适当安放链锯将降低偶然碰到运动链锯的可能性。
 - i) 按照说明书进行润滑、张紧链锯和更换附件。不当张紧或润滑链锯可能会断裂或者增加反弹的可能性。
 - j) 保持手柄干燥、清洁并远离油和油脂。油腻的手柄会打滑并引起失控。
 - k) 只锯割木材。不能将链锯用于其他目的。例如：不能用链锯锯割塑料、石料或非木质建筑材料。用链锯做非预期的操作会引起危险。
6. 使用低回弹链和低回弹导板等装置，以降低回弹产生的风险。
 7. 只使用制造商指定的替换导板和锯链或同等产品。
 8. 不要让移动的锯链接触到导板顶端的任何物体。
 9. 确保工作区域没有障碍物，如其他树木、树枝、岩石、栅栏、树桩。移开或避免您的锯链在切割特定原木或树枝时可能碰到的任何障碍物。
 10. 确保您的锯链锋利，张力适当。锯链松动或钝化后，回弹的风险会增加。在电机停止运动，工具插头拔出的情况下，应定期检查张力，切勿在电机运转的情况下检查。
 11. 锯链全速运转后，方可开始和继续切割。如果锯链移动的速度较慢，发生回弹的可能性就会较大。
 12. 一次切割一根木头。
 13. 重新切割同一根木头时要特别小心。切割前，要将插木齿插入木材，并让锯链全速运转。
 14. 不要尝试切入式切割或钻孔式切割。
 15. 注意移动的原木或其他力量可能会关闭切割，并夹住或落入锯链。

反弹原因和操作者防护：

当导板的前端或顶部碰到物体时，或当锯割时木材并拢而夹住锯链时可能会产生反弹。

某些情况下顶部接触会产生突然的反作用力，将导板向上和向后甩向操作者。

沿导板顶部夹住锯链会快速地将导板反推向操作者。

这些反作用力中每一种都会引起导致严重人身伤害的链锯失控。不要仅仅依赖链锯内设置的安全装置。作为链锯使用者，应该采取多种步骤来保证锯割作业不发生事故或伤害。

工具的误用和/或不正确的操作程序或条件是导致反弹的原因，并可采取以下给出的预防措施来避免：

- a) 保持稳固的握持，用拇指和其他手指握住链锯手柄，用握持链锯的两只手，定位好你的身体和手臂以便你能承受住反弹力。如果采取适当的预防措施，反弹力是可以被操作者控制的。不要听任链锯运转。
- b) 手不得伸得过长且不要在肩部以上进行锯割。这有助于防止意外的顶部接触，并能更好地在意外情况下控制链锯。
- c) 仅使用制造商规定的更换导板和链条。不正确的导板和链条可能会造成断链和/或反弹。
- d) 遵守制造商关于锯链的刃和维护说明。减小深度规高度可导致反弹增加。

通用链锯安全警告

- a) 清理卡住的材料、储存或维修链锯时，请遵循所有的指示。确保开关已关闭，电池包已取出。清理卡住的材料或维修时，链锯意外启动可能造成严重的人身伤害。

应遵循以下预防措施，以最大限度地减少回弹：

1. 牢牢握住链锯。电机运转时，用双手紧紧握住链锯。用拇指和手指环绕链锯手柄，用力握住。沿锯链的下边缘切割时，链锯会向前拉，沿锯链的上边缘切割时，链锯会向后推。
2. 不要过度伸展。
3. 时刻注意立足点和身体平衡。
4. 不要让导板的前端接触到原木、树枝、地面或其他障碍物。
5. 不要在肩部以上的高度切割。

回弹安全功能



警告：您的链锯有以下特点，能降低回弹的风险；但这些特点并不能完全消除这种风险。用户使用链锯时，不能只依赖安全装置。您必须遵守本手册中的所有安全预防措施、说明和维护指南，以尽可能避免回弹和其他可能导致严重伤害的力量。

- 减少回弹的导板，设计有一个小半径的尖端，降低了导板尖端的回弹危险区的尺寸。按照电动链锯的安全要求进行测试时，结果显示：减少回弹的导板可以大大减少回弹的次数和幅度。
- 低回弹链，设计有一个波状深度计和保护链，可以偏转回弹力，让木材逐渐进入切割器。低回弹链是符合ANSI B175.1-2012回弹性能要求的锯链。
- 不得在树上、梯子上、脚手架上或任何不稳定的平面上操作链锯。
- 如果切割时可能会接触到隐蔽线路时，则应使用绝缘的抓握面握住链锯。切割到“带电”的电线可能会使电动工具的裸露金属部分“带电”，并导致操作人员触电。
- 不要尝试超出自己能力或经验的操作。彻底阅读并完全理解本手册中的所有说明。
- 启动链锯之前，请确保锯链没有触碰任何东西。
- 不要单手操作链锯！单手操作可能会对操作者、帮助者或旁观者造成严重伤害。链锯只适合双手使用。
- 保持手柄干燥、清洁、无油或油脂。
- 避免电机或外部通风口上堆积灰尘、碎屑或锯末。
- 在放下链锯之前要先让其停止工作。
- 不要切割藤蔓和/或小型灌木丛。
- 切割小型灌木和树苗时要特别小心，因为细长的材料可能会夹住锯链，并被甩向您或使您失去平衡。

链锯名称和术语

- **造材**——将砍下的树木或原木横切成特定长度的过程。
- **电机制动器(如配备)**——松开启动开关后,用于停止锯链的装置。
- **链锯动力头**——没有锯链和导板的链锯。
- **驱动链轮或链轮**——驱动锯链的齿状部件。
- **伐木**——砍伐树木的过程。
- **伐木回切**——伐木作业中的最后一刀,在树木的另一侧进行,与切口的朝向相反。
- **前手柄**——位于链锯前端或朝向链锯前端的支撑手柄。
- **前护手**——链锯的前手柄和导板之间的结构屏障,通常位于前手柄上靠近手的位置。
- **导板**——支持和引导锯链的坚实的轨道结构。
- **导板护盖**——安装在导板上的外壳,有助于在不使用链锯时防止锯齿接触物体。
- **回弹**——靠近导板顶部区域的锯链接触到任何物体(如原木或树枝)时,或木材在切割过程中合拢并夹住锯链时,导板向后并/或向上运动。
- **回弹,夹住**——当木材靠近并夹住沿导板顶部切割的移动锯链时,链锯可能会快速回弹。
- **回弹,旋转**——当移动的锯链在靠近导板顶端的部分接触到物体(如原木或树枝)时,链锯可能会快速向上和向后运动。
- **削枝**——将树枝从倒下的树上削下。
- **低回弹链**——符合ANSI B175.1-2012回弹性能要求的锯链(代表性链锯通过测试)。
- **正常切割位置**——造材和伐木时的切割位置。
- **下切口**——在树上切割的切口,可以引导树的倾斜方向。
- **后手柄**——位于链锯后端或朝向链锯后端的支撑手柄。
- **减少回弹的导板**——一种经过证明,可以显著减少回弹的导板。
- **替换锯链**——用特定链锯测试时,符合ANSI B175.1-2012回弹性能要求的锯链。但与其他链锯一起使用时,它可能不符合ANSI的性能要求。
- **锯链**——具有切割齿的链环,用于切割木材,由电机驱动,导板支撑。
- **支撑挡边**——在伐木或造材时使用,作为在切割时旋转电链锯的支点并保持位置。
- **开关**——按下后能连通或断开链锯电机的电源电路的装置。
- **开关连杆**——将运动从触发器传递到开关的机构。
- **开关锁**——一个可移动的止动器,可防止意外操作开关,手动打开开关锁后,方可操作开关。

剩余风险

尽管遵守了相关的安全法规并采用了安全装备,某些剩余风险仍然是无法避免的。这些风险包括:

- 听力损伤。
- 飞溅颗粒造成的人身伤害风险。
- 使用时附件发热导致的灼伤风险。
- 长时间使用引起的人身伤害风险。

请妥善保管好这些说明

充电器

DEWALT充电器无需做出任何调整,专为简易操作而设计。

电气安全

电机只适用一种工作电压。请务必检查电池包的电压是否和铭牌上的电压一致。



DEWALT充电器符合IEC60335标准规定的双重绝缘要求,因此无需使用接地线。

如果电源线损坏,必须仅由 DEWALT 或授权的维修机构负责更换。

使用延长线

除非绝对必要,否则请勿使用延长线。使用适合您的充电器输入功率的合格延长线(请参阅**技术数据**)。最小的导线尺寸为1平方毫米;最大长度为30米。使用电缆卷筒时,请务必拉出所有的电缆。

针对所有电池充电器的重要安全说明

请妥善保管好这些说明: 本手册包含重要的兼容电池充电器安全 and 操作说明(请参阅**技术数据**)。

- 在使用充电器之前,请先阅读所有指示以及充电器、电池包和使用电池包的产品上的警告标记。



警告: 电击危险。请勿让任何液体进入充电器,否则可能会导致触电。



警告: 我们建议使用漏电保护额定电流为30毫安或以下的漏电保护装置。



小心: 烧伤危险。为降低人身伤害风险,请仅使用 DEWALT 充电式电池充电。使用其它类型的电池可能会引起爆裂,并导致人身伤害和损害。



小心: 应看管好儿童,以确保他们不将此设备当做玩具来玩。

注意: 在某些情况下,当充电器的插头插入电源插座时,充电器内部裸露的充电接触点可能因为外来物件而短路。请勿让能导电的异物靠近充电器腔,这些外来物件包括但不限于钢棉、铝箔或任何金属颗粒的堆积物。充电器内没有电池包时,请断开充电器与电源的连接。清洗前,务必拔掉充电器。

- 请勿试图使用本手册指定的充电器以外的其他任何充电器为电池包充电。充电器和电池包都是专门设计的,互相配合使用。
- 除了为 DEWALT 充电式电池充电以外,这些充电器并非设计用于其他用途。否则,可能会导致火灾、触电或电击。
- 请勿将充电器暴露于雨中或雪中。

- **断开充电器连接时，应捏住插头将其拔下，而非通过拉拽电源线拔下插头。**这将降低对电插头和电线的损害风险。
- **确保电源线布置在不易踩踏、踢绊、拉扯或会受到损害或压力的位置。**
- **除非绝对必要，否则请勿使用延长线。**使用不正确的延长线可能导致火灾、触电或电击的风险。
- **请勿将任何物件放在充电器上面，或是把充电器放在可能会堵住通风槽的柔软表面，导致充电器的内部过热。**请把充电器放置在远离任何热源的地方。充电器通过外壳顶端和底端的槽进行通风。
- **请勿使用电源线或插头已损坏的充电器，请立即更换这些充电器。**
- **如果充电器受到强烈冲击、掉落或出现其他损坏情况，请勿使用充电器。**请将损坏的充电器送到授权服务中心。
- **请勿自行拆卸充电器。请将需要检修或修理的充电器送到授权服务中心。**重装不正确可能导致触电、电击或火灾风险。
- **必须立即将已损坏的电源线交由制造商、服务代理或类似的合格人员进行更换以防止安全隐患。**
- **清洁前，请先断开充电器和插座的连接，以降低触电风险。**取出电池包不会降低此风险。
- **不得将两个充电器连接在一起。**
- **充电器是为 220-240V 的标准家用电源而设计。请勿试图在任何其他电压下使用充电器。**此规则不适用于车载充电器。

为电池充电 (图 B)









1. 插入电池包前，先将充电器的插头插到相应的电源插座上。
2. 将电池包 **15** 插入充电器，确保电池包在充电器中完全就位。红色 (充电中) 指示灯将不断闪烁，表示充电过程已经开始。
3. 灯持续常亮表示充电完成。电池包已充满电，此时可使用或留在充电器中。要从充电器上取下电池包，请按下电池包上的电池释放按钮 **16**。

注意: 为了确保锂离子电池的效能和使用寿命最大化，在首次使用电池包之前必须将其完全充电。

充电器操作

关于电池包的充电状态，请参阅以下指示灯说明。

充电状态指示灯

	充电中		
	已完全充电		
	热/冷电池包延迟*		

*红色指示灯会继续闪烁，但黄色指示灯在本次操作过程中会亮起。电池包达到适当温度后，黄色指示灯会熄灭，充电器将恢复充电程序。

兼容充电器不会对故障电池包充电充电器指示灯不亮时表示电池有故障。

注意: 这可能也表示充电器有问题。

如果充电器提示存在故障，请将充电器和电池包送到授权的服务中心进行测试。

热/冷电池包延迟

当充电器检测到电池包过热或过冷时，它会启动热/冷电池延迟模式，暂停充电，直到电池包达到适当的温度。然后，充电器会自动切换到电池包充电模式。此功能可确保电池包拥有最长的使用寿命。

冷电池包充电速度比热电池包充电速度慢。电池包在整个充电周期的充电速度都会较慢，即使电池包升温也不会恢复到最大速度。

DCB118 充电器配备了内部风扇，用于冷却电池包。当电池包需要冷却时，该风扇会自动启动。如果风扇无法正常工作或通风槽被堵塞，切勿操作充电器。请勿让异物进入充电器的内部。

电子保护系统

XR 锂离子电池工具采用了电子保护系统设计，可让电池包免受过载、过热或过度放电之害。

如果电子保护系统处于运作状态，该工具将自动停止操作。如果发生这种情况，请将锂离子电池包放在充电器上，直至其完全充电。

壁挂式安装

这些充电器设计为可以安装在墙上，也可以直立在桌面或工作台上。如果安装在墙上，请确保充电器的位置可以连接到电源插座，并且远离墙角或其他可能妨碍空气流通的障碍物。将充电器背面作为在墙上安装螺丝的位置模板。使用至少 25.4 毫米长、螺丝帽直径至少 7.9 毫米的石膏板螺丝 (单独购买) 牢牢固定充电器，将螺丝最大限度打入木材，预留约 5.5 毫米露在墙外。将充电器背面的安装槽对准露出的螺丝，完全放置到位。

充电器清洁说明

警告: 电击危险。清洁前，请将充电器从交流电源插座上拔下。可用布或非金属软刷清除充电器外部的污垢和油脂。请勿使用水或任何清洁剂。不得让任何液体渗入工具，不得让工具的任何部件浸在液体中。

电池包

针对所有电池包的重要安全说明

在订购更换电池包时，请务必附上目录型号和电压。

包装箱内的电池包并未完全充电。使用电池包和充电器之前，请阅读下列安全说明，然后遵循所述的充电程序。

请阅读所有说明

- **请勿在易爆环境，如有易燃液体、气体或粉尘的环境中充电或使用电池。**在充电器中插入或取出电池时可能会点燃粉尘或气体。
- **不得强行将电池放进充电器。请勿以任何方式改装电池包并将电池包插入不兼容的充电器，这种操作可能会导致电池包破裂，造成严重的人身伤害。**
- **只使用 DeWALT 充电器为电池充电。**
- **请勿喷溅电池包或将其浸泡在水或其他液体中。**
- **请勿在温度可能降至 4°C (39.2°F) 的地方 (如冬户外方的棚子或金属建筑物中) 或达到或超过 40°C (104°F)**

的地方(如夏天户外的棚子或金属建筑物中)存储或使用工具和电池包。

- 即使电池包严重受损或完全损坏,也请勿焚化电池包。电池包在火中会发生爆炸。锂离子电池包在燃烧时会释放有毒气体和物质。
- 如果电池液体接触到皮肤,请立即以中性肥皂和清水冲洗接触的地方。如果电池液体不慎进入眼睛,应睁开眼睛并用清水冲洗至少 15 分钟或直到刺激感消失。如果需要医疗救助,请告知医护人员。电池电解质由液状有机碳酸盐和锂盐的混合物组成。
- 已打开电池的内部物质可能导致呼吸道刺激。请保持空气流通。如果症状持续存在,请就医。

 **警告:** 烧伤危险。电池液如果接触到火花或火焰可能会燃烧。

 **警告:** 不得以任何理由试图打开电池包。电池包外壳破裂或损坏时,请勿将电池包插入充电器。请勿挤压、掉落或损坏电池包。请勿使用受过强烈重击、掉落、碾压或以任何其它方式(如被钉子穿破、受到锤子的重击、踩踏)受损的电池包或充电器。否则可能会引起触电或电击。损坏的电池包应送回服务中心进行处理。

 **警告:** 火灾危险。请勿在存储或搬运电池包时让金属物品接触暴露的电池两极。例如,请勿将电池包放在围裙、口袋、工具箱、产品套件盒、抽屉等可能与散钉、螺丝、钥匙等物品接触的地方。

 **小心:** 不使用时,应将工具侧放在稳定的表面上,以免造成绊倒或坠落的危险。一些带有大型电池包的工具有可以直立在电池包上,但可能很容易被撞倒。

运输

 **警告:** 火灾危险。电池运输途中,如果电池两极意外接触导电材料,可能会引发火灾。运输电池时,务必保护电池两极,确保与可能接触电池导致短路的材料良好绝缘。**注意:** 不应将锂离子电池放入托运行李中。

DEWALT 电池符合所有适用的行业和法律标准规定的运输规范,包括《联合国危险品运输建议规章范本》(UN Recommendations on the Transport of Dangerous Goods)、《国际航空运输协会(IATA)危险品规则》(International Air Transport Association (IATA) Dangerous Goods Regulations)、《国际海运危险品(IMDG)规则》(International Maritime Dangerous Goods (IMDG) Regulations)和《欧洲危险货物国际公路运输协定》(European Agreement Concerning The International Carriage of Dangerous Goods by Road) (ADR)。离子电池和电池包已遵循《联合国危险品运输建议规章范本手册》第 38.3 节关于测试和标准的说明通过测试。大多数情况下,发运 DEWALT 电池包不属于完全管制的 9 类危险品。通常情况下,只有当运输包含一个能量等级大于 100 瓦时(Wh)的锂离子电池时,才需要作为完全管制的 9 类危险品发运。所有锂离子电池外壳上均标注有瓦时等级。此外,由于法规比较复杂,无论瓦时等级是多少,DEWALT 都不建议单独空运锂离子电池。发运包含电池的工作(组合套件)时,如果电池包的能量等级不大于 100 瓦时(Wh),则可以按计划空运。

无论发运是否纳入完全管制范围内,运输公司均有责任遵循最新法规中关于包装、标签/标记和单据的要求。本手册本节的信息是出于善意提供,且认为在编制文档时准确无误。不提供明示或暗示的担保。购买方负有确保其行为遵守适用法规的责任。

运输 FLEXVOLT™ 电池

DEWALT FLEXVOLT™ 电池有两种模式:使用和运输。

使用模式: 当 FLEXVOLT™ 电池单独使用或置于 DEWALT 18V (最大 20V) 产品中时,将作为 18V (最大 20V) 电池运行。当 FLEXVOLT™ 电池在 54V (最大 60V) 或 108V (最大 120V) (两块 54V (最大 60V) 电池) 产品中时,其将作为 54V (最大 60V) 电池运行。

运输方式: 当盖子连接到 FLEXVOLT™ 电池时,电池处于运输模式。盖住盖子以便进行运输。

处于运输模式时,断开电池包的电源会产生 3 个瓦特小时额定值 (Wh) 较低的电池,和 1 个瓦特小时额定值较高的电池。这种增加的 3 个瓦特小时额定值较低的电池可使电池包免于遵守某些对高瓦特小时电池施加的运输规定。

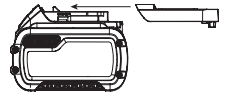

例如,运输 Wh 额定值可能表示为 3x36Wh,即每节 36Wh 的 3 节电池。使用 Wh 额定值可能表示 108Wh (1 个电池)。

使用和运送标签标记示例



存放建议

1. 最好将电池存放在阴凉、干燥、远离阳光直射、不会过热或过冷的地方。为了获得最佳的电池性能和使用寿命,请您在不使用电池包时将其存储在室温下。
2. 长期存储时,建议将完全充电的电池包从充电器取出,存储在阴凉、干燥的地方,以达到最佳效果。

注意: 电池包不应在电池已完全耗尽的状态下存放。使用电池包之前,必须重新为电池包充电。

充电器和电池包上的标签

除了在本手册中所使用的标志,充电器和电池包的标签还包括:



使用前请阅读使用手册。



如需了解充电时间详细信息,请参阅 **技术数据**。



请勿使用导电物体戳刺。



请勿对损坏的电池包充电。



请勿将其暴露于水中。



应立即更换有缺陷的电线。



请只在4°C和40°C之间的温度下充电。



只能在室内使用。



弃置电池包时，请妥善处理以保护我们的环境。



仅使用指定的DeWALT充电器为电池包充电。使用DeWALT充电器为非DeWALT电池充电可能会导致电池爆炸或出现其他危险情况



请勿焚化电池包。



使用(不含运输盖)示例:Wh额定值表示108Wh(1个108Wh的电池)。



运输(带内置运输盖)。示例:Wh额定值表示3 x 36 Wh(3个36Wh的电池)。

电池类型

以下工具使用54伏(最大60V)的电池包:DCMCS574、DCMCS575

可使用这些电池包:DCB546、DCB547、DCB548、DCB549、DCB606、DCB609、DCB612、DCB615。更多信息,请参考**技术数据**。

包装内的物品

DCMCS574的包装中包含:

- 1把 链锯
- 1个 导板护盖
- 1根 45厘米导板
- 1条 45厘米的锯链
- 1把 扳手
- 1本 使用手册

DCMCS575的包装中包含:

- 1把 链锯
- 1个 导板护盖
- 1根 50厘米导板
- 1条 50厘米的锯链
- 1把 扳手
- 1本 使用手册

注意:电池包、充电器和工具箱没有随 N 型号附送。电池包和充电器没有随 NT 型号附送。B型号包括蓝牙®电池包。

注意:Bluetooth®标志和徽标是Bluetooth®, SIG, Inc.的注册商标,DeWALT对这些标识的任何使用均经过许可。其他商标和商名均归各自所有者所有。

- 检查工具、部件或附件是否在运输过程中损坏。
- 操作前,请抽空仔细阅读并掌握本手册。

工具上的标记

工具上印有下列图形:



使用前请阅读使用手册。



请佩戴听力保护器。



请佩戴护目装备。



请佩戴头部保护装备。



请佩戴手套。



请佩戴适当的脚部保护装备。



请勿将工具暴露在雨中或高湿度环境中,也不要在雨时将工具放在室外。



应避免导板尖端与任何物体接触。



锯链的旋转方向。



操作电锯时,始终使用两只手。



关闭工具。在对工具进行任何维护之前,请将电池从工具中取出。

日期代码位置(图A)

包含制造年份的日期码 18, 打印在工具外壳上。

示例:

2022 XX XX
制造年份和周

说明(图A)

警告:不得改装本电动工具或其任何部件,否则可能会导致损坏或人身伤害。

- 1 启动开关
- 2 开关锁
- 3 链式制动器/前护手
- 4 导板
- 5 锯链
- 6 链轮盖
- 7 导板锁紧螺母
- 8 锯链张紧螺丝
- 9 油位指示器
- 10 油壶盖
- 11 导板护盖
- 12 后手柄
- 13 前手柄
- 14 电池外壳
- 15 电池包
- 16 电池释放按钮
- 17 扳手
- 18 日期代码

设计用途

DCMCS574链锯设计用于切割直径40厘米以下的原木。

DCMCS575链锯设计用于切割直径45厘米以下的原木。

请勿在潮湿环境中，或在存在易燃液体或气体的环境中使用本工具。

这些链锯是专业的电动工具。

请勿让儿童接触本工具。缺乏经验的操作员需要在监督下使用本工具。

- **儿童和体弱者。**在没有他人监督的情况下，儿童或体弱者不适宜使用本产品。
- 本产品不适合体力、感官或智力不足以及缺乏经验、知识或技能的人员（包括儿童）使用，除非一旁有能为他们的安全负责的监督人员。不得在无人监管的情况下让儿童接触本产品。

组装与调整

 **警告：**为降低严重的人身伤害风险，在进行任何调整或取出/安装附件或配件之前，请关闭工具并断开电池包连接。意外启动可能会导致人身伤害。

 **警告：**仅使用DEWALT电池包和充电器。

插入或取出工具上的电池包(图D)

注意：确保您的电池包 **15** 已经充满电。

将电池包安装到工具中

1. 将电池包 **15** 对准工具电池外壳 **14** 的轨道(图D)。
2. 将电池包滑入电池外壳内，使其牢牢地固定在工具内，并确保您听到其锁定到位的声音。

从工具中取出电池包

1. 按下电池释放按钮 **16**，将电池包从工具握柄中稳妥地拉出。
2. 按本手册充电器部分所述将电池包插入充电器中。

电池包电量计(图C)

一些DEWALT电池包带有一个包含三个绿色LED指示灯的电量计，用于指示电池包内的剩余电量。

按下电量计按钮 **19** 不松开，即可启动电量计。三个绿色LED指示灯将以组合方式亮起，以指示剩余电量。当电池内的电量低于可用限制时，电量计将不会亮起，电池将需要重新充电。

注意：电量计仅指示电池包的剩余电量。它并不表示该工具的功能，且将根据产品组件、温度和最终使用者的使用情况而有所不同。

安装导板和锯链(图A, E-G)

 **小心：**锯链很锋利。处理锯链时一定要戴上防护手套。锯链很锋利，静止状态下也可能割伤您。

 **警告：**移动锯链很锋利。为防止意外操作，在进行以下操作前，请确保电池从工具中取出。如果不这样做，可能会导致严重的人身伤害。

如果锯链 **5** 和导板 **4** 在纸箱中分开包装，则必须将锯链连接到导板上，并且两者都必须连接到工具的主体上。

1. 将链锯放在平坦、坚固的表面上。
2. 用随附扳手 **17** 逆时针旋转锯链的导板锁紧螺母 **7**。
3. 卸下链轮盖 **6** 和导板锁紧螺母 **7**。
4. 戴上防护手套，抓住锯链 **5** 并将其缠绕在导板 **4** 上，确保锯齿朝向正确。
5. 确保锯链正确地设置在整个导板周围的槽中。
6. 将锯链放在链轮 **20** 上。同时将导板上的槽与锯链张紧销 **21**，以及工具基本上的螺栓 **22** 对准，如图E所示。
7. 对准后，保持导板不动，更换链轮盖 **6**。确保盖子上的螺栓孔与主壳体上的螺栓 **22** 对齐。
8. 安装导板锁紧螺母 **7**，用随附扳手 **17** 顺时针旋转，直到紧固，然后将导板锁紧螺母松开一整圈，这样锯链就可以进行适当张紧了。
9. 用扳手 **17** 的平头螺丝刀一端顺时针旋转锯链张紧螺丝 **8**，以增加张力。如图F和图G所示，确保锯链 **5** 紧贴于导板 **4** 上，然后拧紧导板锁紧螺母 **7**，直至紧贴。
10. 按照“调整锯链张力”一节的说明进行操作。

调整锯链张力(图A, E-G)

注意：每次使用前，应定期调整锯链的张力。

1. 当链锯仍在坚固的表面上时，检查锯链 **5** 的张力。如图F所示，用中指和拇指轻轻地锯链从导板 **4** 上拉开6毫米后，锯链就会被拉回，这时的张力是正确的，如图G所示，导板和锯链底部之间不应有“下垂”。
2. 如需调整锯链的张力，松开导板锁紧螺母 **7**。
3. 用扳手 **17** 的平头螺丝刀端旋转位于链轮盖上的锯链张力螺丝 **8**。
4. 检查锯链的张力，如有需要可进行调整。
5. 不要过度拉紧锯链，这会导致过度磨损，并会减少导板和锯链的使用寿命。
6. 锯链张力正确后，用6英尺磅(8牛米)的扭矩将导板锁紧螺母 **7** 拧紧。(8 Nm)。
7. 新锯链在使用的前几个小时会有轻微的拉伸。在使用的前两个小时，必须经常检查张力(在取出电池包后)。

更换锯链(图A, E, H)

 **小心：**锯链很锋利。处理锯链时一定要戴上防护手套。锯链很锋利，静止状态下也可能割伤您。

 **警告：**移动锯链很锋利。为防止意外操作，在进行以下操作前，请确保电池从工具中取出。如果不这样做，可能会导致严重的人身伤害。

1. 如需卸下锯链 **5**，应将锯链放在平坦、坚固的表面上。
2. 如**安装导板和锯链**一节所述，卸下链轮盖 **6**。
3. 用扳手 **17** 的平头螺丝刀端旋转锯链张力螺丝 **8**。逆时针旋转螺丝可使导板 **4** 后退，并减少锯链上的张力，从而将其拆除。
4. 戴上防护手套，抓住锯链，将磨损的锯链从导板的凹槽中取出。
5. 每次更换锯链时都要把导板翻过来，以确保磨损均匀。

- 将新锯链放入导板的槽中,通过匹配链轮盖 6 上锯链的箭头和图形,确保锯齿朝向正确的方向,如图H。
- 遵循 **安装导板和锯链** 的指示操作。

如需**替换锯链和导板**,可联系您身边的授权服务中心。

- DCMCS574链锯的可替换锯链型号为DWO1DT618,长45cm;可替换导板型号为DWZCSB18,长45cm。
- DCMCS575链锯的可替换锯链型号为DWO1DT620,长50cm;可替换导板型号为DWZCSB20,长50cm。

锯链和导板上油(图A)

自动上油系统

本链锯配有自动上油系统,能持续润滑锯链和导板。油位指示器 9 显示链锯中的油位。如果油位低于四分之一处,请将电池从链锯上取下,并加注正确类型的油。切割结束后一定要排空油壶。

注意:请使用高品质导板和锯链油,以确保锯链正常工作,正常润滑。非清洁剂的SAE30机油可以用作临时替代品。修剪树木时,建议使用植物基导板和锯链油。矿物油可能伤害树木,所以不建议使用。切勿使用废油或稠油。它们可能会损坏您的链锯。

在油壶中加油

- 逆时针拧开并取下油壶盖 10。在油壶中注入推荐的导板和锯链油,直到油位达到油位指示器 9 的顶部。
- 重新盖上油壶盖并顺时针拧紧。
- 定期关闭链锯并检查油位指示器,以确保导板和锯链的油量充足。

运输链锯(图A)

- 运输链锯时,一定要把电池从工具上取下,并用导板护盖 11 覆盖导板 4。

操作

使用说明

警告:务必遵守安全指示和适用法规。

警告:为降低严重的人身伤害风险,在进行任何调整或取出/安装附件或配件之前,请关闭工具并断开电池包连接。意外启动可能会导致人身伤害。

正确的双手放置位置(图I)

警告:为了减低严重人身伤害的风险,请务必如图示那样正确放置双手。

警告:为了减低造成严重人身伤害的风险,预期有突然反作用力时**务必**握紧。

正确的双手放置位置要求左手放在前手柄 13 上,右手放在后手柄 12 上。

操作链锯(图A、I、K)

警告:阅读并理解所有说明。未能遵照以下所列说明会引发电击、火灾和/或严重人身伤害。

- 避免发生回弹,回弹会导致人身严重伤害或死亡。请参阅**电动工具通用安全警告**和**电锯通用安全警告**,以及**回弹的原因和操作员的**

预防回弹和回弹安全功能,以避免回弹的风险。

- 请勿过分伸展。不要在胸部以上的高度切割。确保双脚站立的表面牢固。保持双脚分开。将体重平均分配在两脚上。
- 用左手握住前手柄 13,右手握住后手柄 12,使身体处于导板的左边,用力握紧。
- 不要用链式制动器/前护手 3 握住链锯。保持左臂肘部锁定,使左臂伸直,以抵御回弹。



警告:切勿使用交叉手握的方式(左手握后手柄,右手握前手柄)。



警告:操作链锯时,切勿让身体的任何部分与导板 4 平行。

不要在树上、高难度位置,梯子或其他不稳定的表面上作业。您可能会失去对链锯的控制,受到严重伤害。

- 在整个切割过程中,保持链锯全速运行。
- 让链锯的锯链为您所用。只施加轻微的压力。在切割结束时不要对链锯施加压力。



警告:不使用链锯时,一定要拉上链式制动器并取下电池。

设置锯链制动器(图K)

您的链锯配备了锯链制动系统,在出现回弹时能迅速让锯链停止工作。

- 从工具中取出电池。
- 要启动链式制动器,请将链式制动器/前护手 3 向前推,直到其卡入到位。
- 如图K所示,将锯链制动器/前护手 3 向前手柄 13 拉到“设定”位置。
- 该工具现在可以使用了。

注意:发生回弹时,您的左手将接触到前护手,将其朝着工件向前推。这将使工具停止工作。

测试锯链制动器(图A、K)

每次使用前都要测试锯链制动器,以确保其操作正常。

- 将工具放在平坦、坚固的表面上。确保锯链 5 与地面无接触。
- 双手紧握工具,打开链锯。
- 将左手绕着前手柄 13 向前旋转,使手背接触到锯链制动器/前护手 3,并将其朝着工件向前推。锯链应立即停止工作。

注意:如果链锯没有立即停止工作,请停止使用工具并将其送到您身边的授权服务中心。



警告:切割前,请正确设置锯链制动器。

开/关(图J)

双脚始终站稳,用双手紧紧抓住链锯,拇指和手指环绕着两个手柄。

- 要打开设备,按下开关锁 2,如图J所示,并按压启动开关 1。设备运转起来后,即可松开开关锁。
- 为了保持设备运行,您必须继续按压启动开关。要关闭设备,请释放启动开关。

注意:如果在切割时用力过猛,链锯将被关闭。要重新启动链锯,你必须在链锯重新启动前释放启动开关 ❶。再次开始切割,这次要减少施加的力量。让链锯以自己的速度切割。

警告:切勿试图将开关锁定在开启位置。

常用切割技术

伐木

砍掉一棵树的过程。不要在刮大风时砍树。

警告:伐木可能导致人员受伤。只应安排受过训练的人员伐木。

- 开始伐木之前,应根据需要规划并清理出一条撤退路径。撤退路径应向后延伸,并斜向延伸到预期倒伏线的后面,如下图所示。

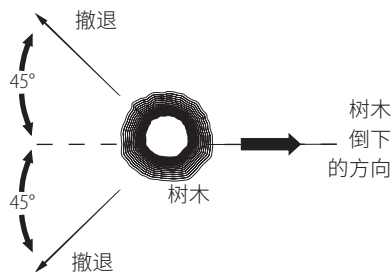

- 开始砍伐之前,应考虑树木的自然倾斜度、较大树枝的位置和风向,以判断树木将从哪个方向倒下。准备好楔子(木头、塑料或铝)和一个重锤。从要砍伐的树上清除泥土、石头、松动的树皮、钉子、订书针和铁丝。
- 下切切口**——切口深度为树木直径的1/3,垂直于倒下的方向。首先切出下部的水平切口。这样有助于避免切割第二道缺口时锯链或导板被夹住,如下图所示。
- 伐木回切切口**——伐木回切切口至少比水平切割切口高51毫米。伐木回切切口应与水平切割切口平行。伐木回切切口上要留有足够的木材用作铰链。铰链木材可以防止树木扭曲,以及向错误的方向倒下。不要切开铰链,如下图所示。
- 切割深度接近铰链时,树木应该开始倒下。如果树木可能不按目标方向倒下,或者可能向后摇晃并压住锯链,请在伐木完成之前停止切割,并使用楔子打开切口,将树木沿目标方向落下。当树木开始倒下时,将电锯从切口处移开,关闭电机,将电锯放下,然后按照计划的撤退路径离开。警惕高空坠落的树枝,注意脚下安全。

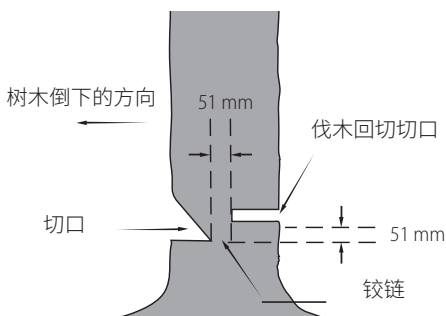

削枝

将树枝从倒下的树上削下。削枝时,留下较大的树枝以支撑离地的原木。将较小的枝条一次削掉。对于紧绷的树枝,应从底部树枝向顶部树枝切割,以避免缠住电锯,如下图所示。从对面修剪枝条时,确保树干在您和链锯之间。切勿将链锯夹在两腿之间进行切割,或跨坐在要切割的树枝上。

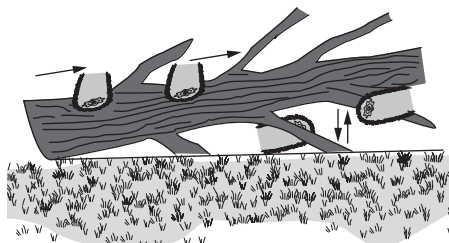

造材

警告:建议第一次使用链锯的人员先在锯马上练习切割。

将砍下的树木或原木切割成相应长度。切割方式取决于原木的支撑方式。尽可能使用锯马,如下图所示。

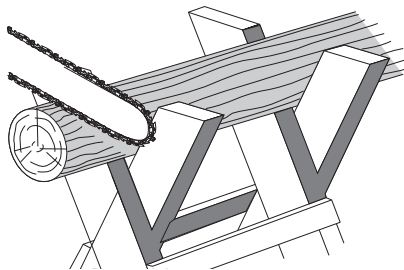

- 始终在锯链全速运行的情况下开始切割。
- 如下图所示,将链锯的底部钉子 23 放在最初切割的区域后面。
- 打开电锯,然后将锯链和导板旋入树中,用钉子作为铰链。
- 电锯转到45°角后,再次调平电锯,重复这个步骤,直到完全切开。
- 当树木整体被撑起时,从顶部(overbuck)进行切割,但要避免切割泥土,因为这将使你的链锯迅速变钝。

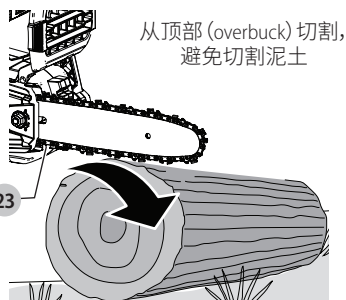

- 当一端有支撑时，从底部 (underbuck) 切割1/3直径的深度。然后，如下图所示，从顶部完成切割，对准第一次切割的切口。

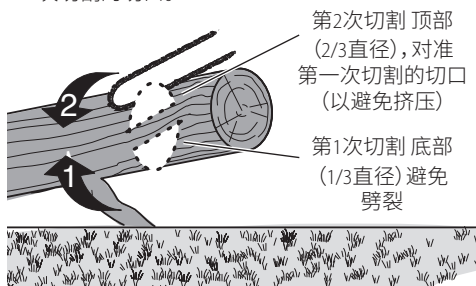

- 当两端都有支撑时。首先，从顶部向下切割1/3直径的深度。然后，如下图所示，从底部切割2/3直径的深度，对准第一次切割的切口，完成切割。

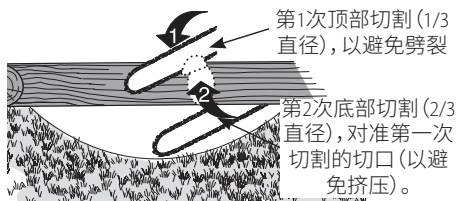

- 在斜坡上切割时，永远站在原木的上坡一侧。“切开”后，为了保持完全控制，在接近切口的时候应减少施加的压力，但不要减少抓握链锯手柄的力度。不要让锯链接触地面。完成切割后，等待锯链停止，然后再移动链锯。从一个切口移动到另一个切口时，一定要让电机工作。

维护

您的电动工具设计精良，可以长期使用，仅需极少维护。若要持续令人满意的工作效果，则需对工具进行适当的保养和定期清洁。

- 警告：**为降低严重的人身伤害风险，在进行任何调整或取出/安装附件或配件之前，请关闭工具并断开电池包连接。意外启动可能会导致人身伤害。

充电器和电池包无法维修。

锯链的锋利度

- 小心：**锯链很锋利。处理锯链时一定要戴上防护手套。锯链很锋利，静止状态下也可能割伤您。

重要事项：如果在切割时接触到地面、石头、砖石或钉子，锯链切割器会立即变钝。

为了让您的链锯发挥出最佳性能，确保锯链齿锋利是非常重要的。离您最近的DEWALT服务中心可以提供锯链研磨服务。

注意：锯链每研磨一次，减少回弹的特性就会少一些，应特别小心。建议锯链的研磨次数不超过四次。



润滑

本电动工具无需另行润滑



清洁

- 警告：**一旦看到通风口及其周围积聚了尘屑，请用干燥的空气将灰尘和尘屑从主机外壳内吹出。执行此过程时，需戴上经认可的护目装备和防尘面具。

- 警告：**不得使用溶剂或其它刺激性化学制品来清洁工具的非金属部件。这些化学物质可能会削弱这些部位使用的材料。请用布蘸温和的肥皂水擦拭。不得让任何液体渗入工具，不得让工具的任何部件浸在液体中。

可选配件

- 警告：**由于除DEWALT提供的配件外，其他配件没有经过本产品的测试，因此将这些配件与本工具一起使用可能会有危险。为了减少受伤的风险，本产品仅可使用DEWALT推荐的配件。

请向您的经销商咨询更多关于合适附件的信息。

保护环境

分类回收。由此符号标记的产品和电池不得与普通家庭垃圾一起处理。

产品和电池包含可恢复或回收的材料，从而降低对原材料的需求。请根据当地规定回收电子产品和电池。要获得更多信息，请参看www.2helpU.com。

充电式电池包

本电池包使用寿命长，不能提供顺利完成工作所需的电力时，必须进行充电。电池技术寿命结束时，请妥善处理以保护环境：

- 耗尽电池包的电力，然后将其从工具上拆下。
- 锂离子电池是可回收的。请将它们送往您的经销商处或当地的回收站。回收的电池包将被妥善循环使用或处理。

售后服务和维修

DeWALT服务中心配备了训练有素的人员,能为客户提供高效、可靠的产品服务。如果您在未经授权的服务中心进行维修,我们不承担任何责任。您可以参见产品包装中的“联系中心定位器”宣传单页,通过热线电话、网站或社交媒体联系我们,找到距离您最近的DeWALT服务中心。

制 造 商: 百得美国公司
地 址: 701 E Joppa Rd, TW050 MD21286, Towson,
美国
产 地: 江苏苏州

