

DEWALT®

XR®

Fig. A
图A

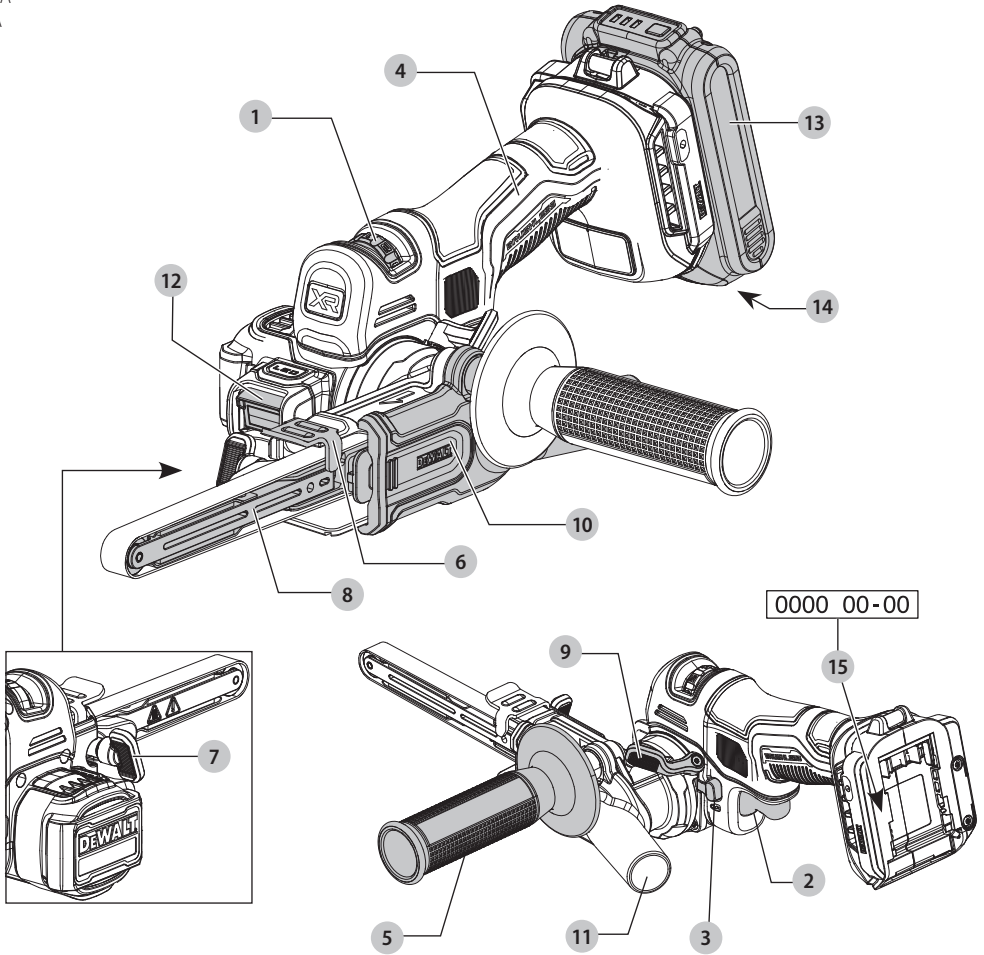

Fig. B
图B

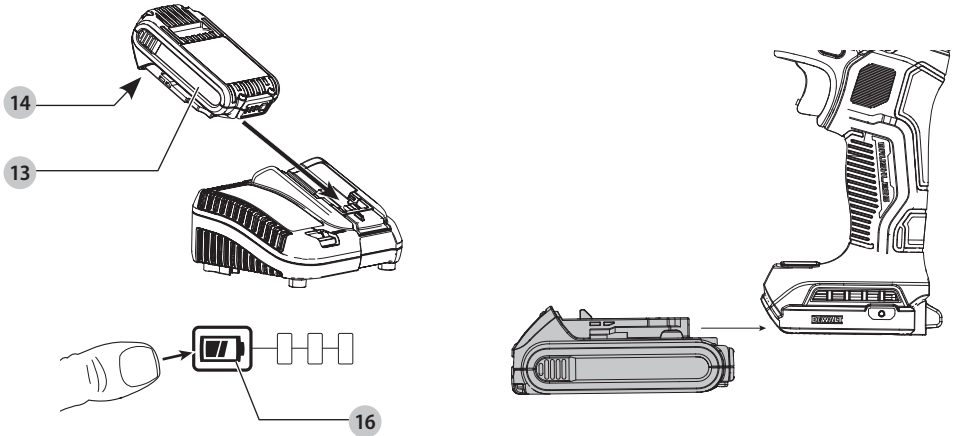

Fig. C
图C

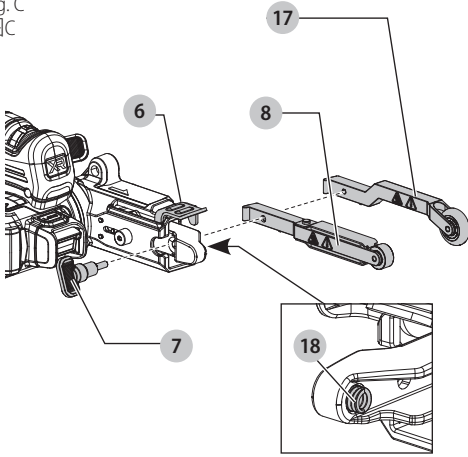

Fig. D
图D

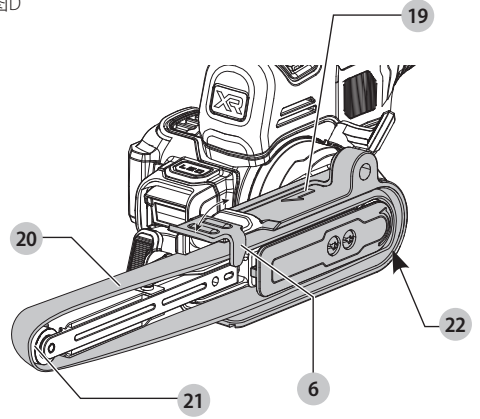

Fig. E1
图E1

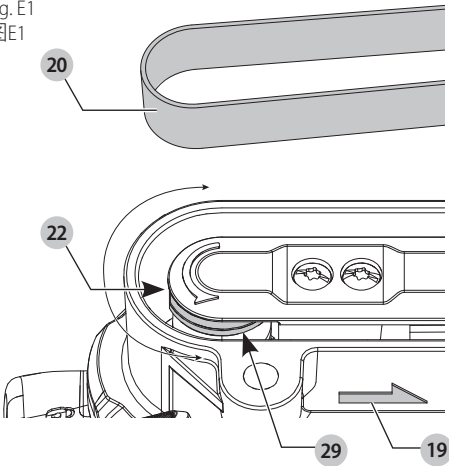

Fig. E2
图E2

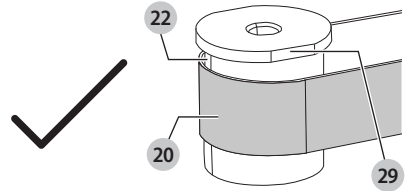

Fig. E3
图E3

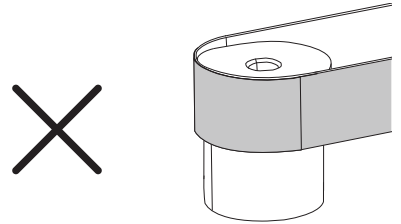

Fig. F
图F

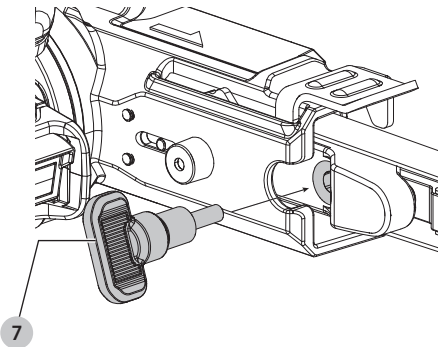

Fig. G
图G

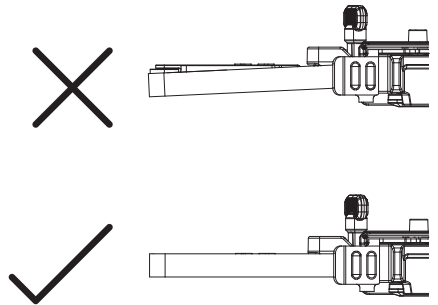

Fig. H
图H

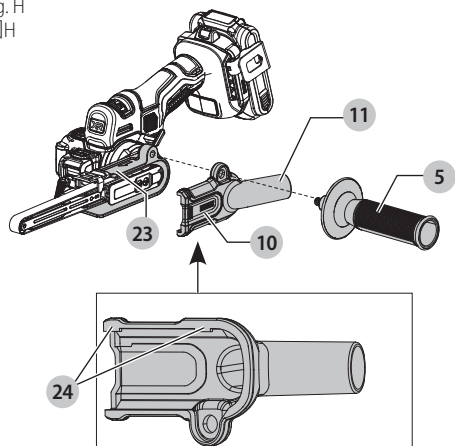

Fig. I
图I

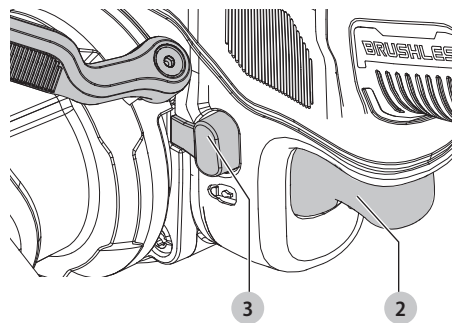

Fig. J
图J

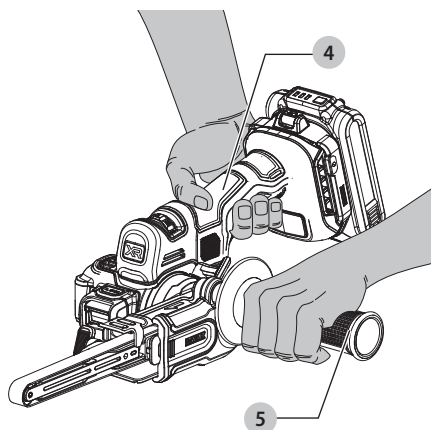

Fig. K
图K

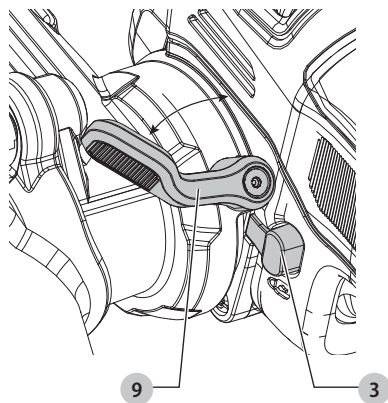

Fig. L
图L

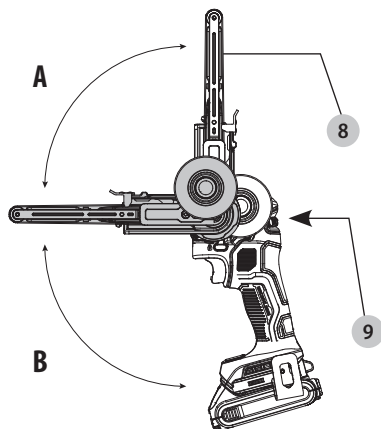

Fig. M
图M

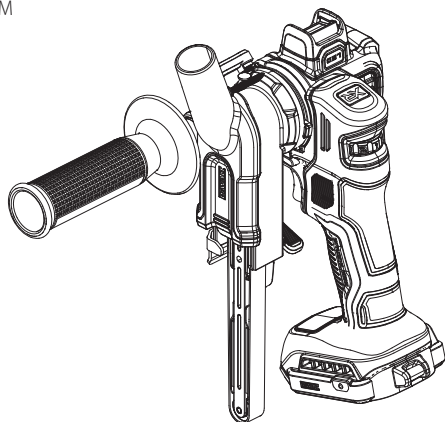

Fig. N
图N

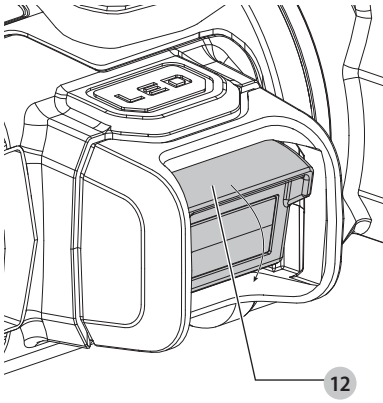

Fig. O
图O

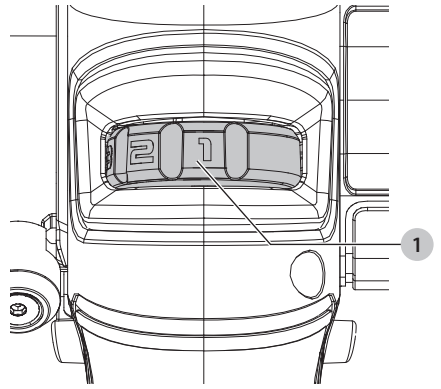

Fig. P
图P

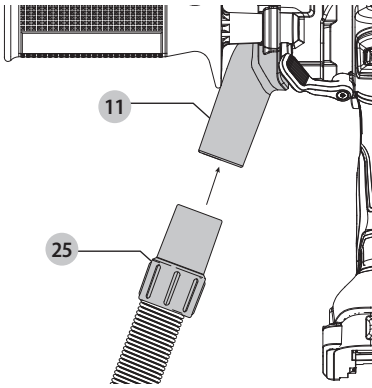

Fig. Q
图Q

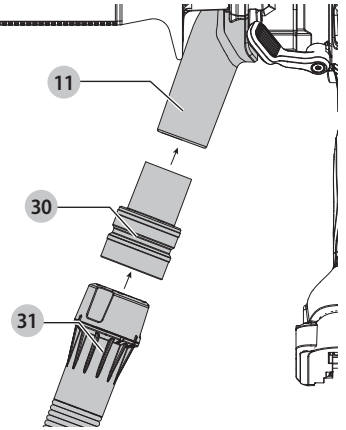

Fig. R
图R

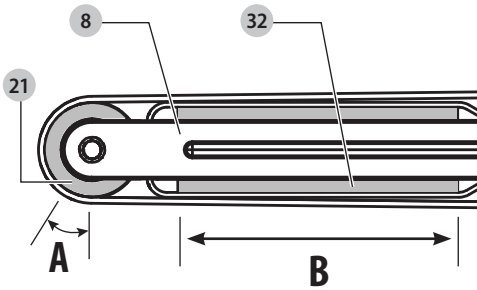

Fig. S
图S

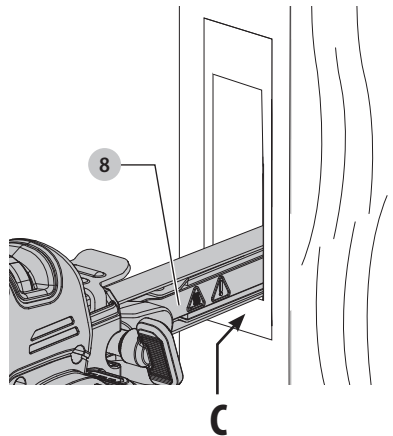

Fig. T
图T

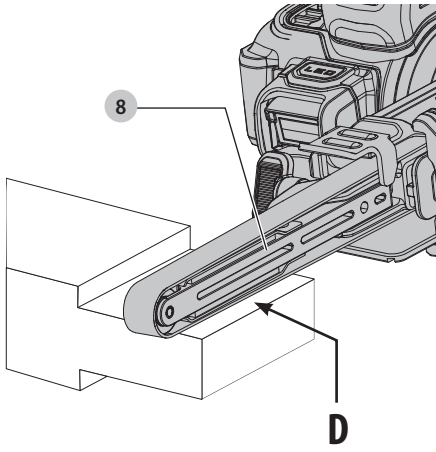

Fig. U
图U

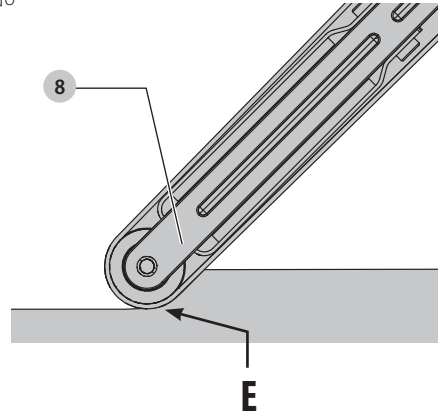

Fig. V
图V

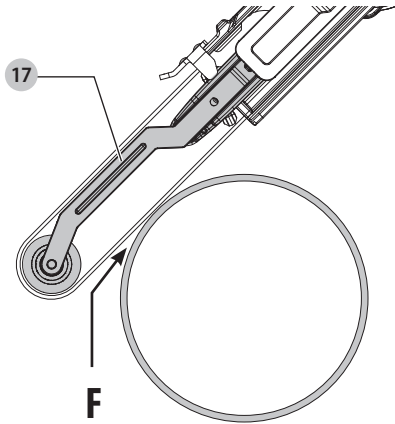
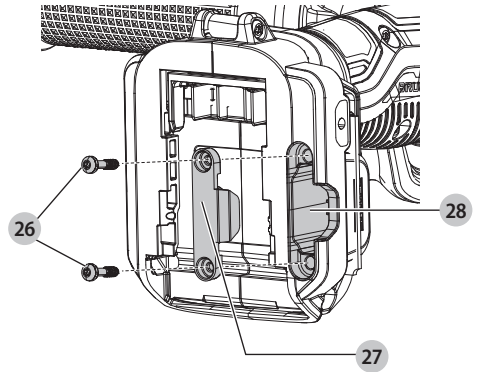

Fig. W
图W



BANDFILE

DCM200

Congratulations!

You have chosen a DeWALT tool. Years of experience, thorough product development and innovation make DeWALT one of the most reliable partners for professional power tool users.

Technical Data

			DCM200
Voltage	V _{DC}		18(20 Max)
Battery type			Li-Ion
No-load speed	m/min		600–1700
Belt size	mm		13 x 457
Weight(without battery pack)	kg		1.3

Batteries				Chargers / Charge Times (Minutes)						
Cat#	V _{DC}	Ah	Weight(kg)	DCB104	DCB107	DCB112 DCB1102	DCB115 DCB1104	DCB117 DCB1112	DCB118	DCB132
DCB546/DCB606	18/54 (20/60 Max)	6.0/2.0	1.08	60	270	170	90	40	60	90
DCB547/DCB609/ DCB609G	18/54 (20/60 Max)	9.0/3.0	1.46	75*	420	270	135*	60	75*	135*
DCB548/DCB612	18/54 (20/60 Max)	12.0/4.0	1.46	120	540	350	180	80	120	180
DCB180	18 (20 Max)	3.0	0.62	45	140	90	45	45	45	45
DCB181	18 (20 Max)	1.5	0.35	22	70	45	22	22	22	22
DCB182/DCB204	18 (20 Max)	4.0	0.61	60/40**	185	120	60	60/40**	60/40**	60
DCB183/DCB203	18 (20 Max)	2.0	0.40	30	90	60	30	30	30	30
DCB184/DCB184G/ DCB205	18 (20 Max)	5.0	0.62	75/50**	240	150	75	75/50**	75/50**	75
DCB187	18 (20 Max)	3.0	0.54	45	140	90	45	45	45	45
DCB189/DCB240	18 (20 Max)	4.0	0.54	60	185	120	60	60	60	60
DCB186	18 (20 Max)	6.0	0.95	60	270	170	90	60	60	90
DCB208	18 (20 Max)	8.0	0.95	70	360	240	120	70	70	120
DCBP034	18 (20 Max)	1.7	0.32	27	82	50	27	27	27	27
DCBP520	18 (20 Max)	5.0	0.75	75/50**	240	150	75	75/50**	75/50**	75

*Date code 201811475B or later

**Date code 201536 or later

***Battery charge times matrix provided for guidance only; charge times will vary depending on temperature and condition of batteries.



WARNING: To reduce the risk of injury, read the instruction manual.

Definitions: Safety Guidelines

The definitions below describe the level of severity for each signal word. Please read the manual and pay attention to these symbols.



DANGER: Indicates an imminently hazardous situation which, if not avoided, **will** result in **death or serious injury**.



WARNING: Indicates a potentially hazardous situation which, if not avoided, **could** result in **death or serious injury**.



CAUTION: Indicates a potentially hazardous situation which, if not avoided, **may** result in **minor or moderate injury**.

NOTICE: Indicates a practice **not related to personal injury** which, if not avoided, **may** result in **property damage**.



Denotes risk of electric shock.



Denotes risk of fire.

GENERAL POWER TOOL SAFETY WARNINGS



WARNING: Read all safety warnings, instructions, illustrations and specifications provided with this power tool. Failure to follow all instructions listed below may result in electric shock, fire and/or serious injury.

SAVE ALL WARNINGS AND INSTRUCTIONS FOR FUTURE REFERENCE

The term "power tool" in the warnings refers to your mains-operated (corded) power tool or battery-operated (cordless) power tool.

1) Work Area Safety

- Keep work area clean and well lit.** Cluttered or dark areas invite accidents.
- Do not operate power tools in explosive atmospheres, such as in the presence of flammable liquids, gases or dust.** Power tools create sparks which may ignite the dust or fumes.
- Keep children and bystanders away while operating a power tool.** Distractions can cause you to lose control.

2) Electrical Safety

- Power tool plugs must match the outlet. Never modify the plug in any way. Do not use any adapter plugs with earthed (grounded) power tools.** Unmodified plugs and matching outlets will reduce risk of electric shock.
- Avoid body contact with earthed or grounded surfaces, such as pipes, radiators, ranges and refrigerators.** There is an increased risk of electric shock if your body is earthed or grounded.
- Do not expose power tools to rain or wet conditions.** Water entering a power tool will increase the risk of electric shock.

- Do not abuse the cord. Never use the cord for carrying, pulling or unplugging the power tool. Keep cord away from heat, oil, sharp edges or moving parts.** Damaged or entangled cords increase the risk of electric shock.
- When operating a power tool outdoors, use an extension cord suitable for outdoor use.** Use of a cord suitable for outdoor use reduces the risk of electric shock.
- If operating a power tool in a damp location is unavoidable, use a residual current device (RCD) protected supply.** Use of an RCD reduces the risk of electric shock.

3) Personal Safety

- Stay alert, watch what you are doing and use common sense when operating a power tool. Do not use a power tool while you are tired or under the influence of drugs, alcohol or medication.** A moment of inattention while operating power tools may result in serious personal injury.
- Use personal protective equipment. Always wear eye protection.** Protective equipment such as a dust mask, non-skid safety shoes, hard hat or hearing protection used for appropriate conditions will reduce personal injuries.
- Prevent unintentional starting. Ensure the switch is in the off position before connecting to power source and/or battery pack, picking up or carrying the tool.** Carrying power tools with your finger on the switch or energising power tools that have the switch on invites accidents.
- Remove any adjusting key or wrench before turning the power tool on.** A wrench or a key left attached to a rotating part of the power tool may result in personal injury.
- Do not overreach. Keep proper footing and balance at all times.** This enables better control of the power tool in unexpected situations.
- Dress properly. Do not wear loose clothing or jewellery. Keep your hair and clothing away from moving parts.** Loose clothes, jewellery or long hair can be caught in moving parts.
- If devices are provided for the connection of dust extraction and collection facilities, ensure these are connected and properly used.** Use of dust collection can reduce dust-related hazards.
- Do not let familiarity gained from frequent use of tools allow you to become complacent and ignore tool safety principles.** A careless action can cause severe injury within a fraction of a second.

4) Power Tool Use and Care

- Do not force the power tool. Use the correct power tool for your application.** The correct power tool will do the job better and safer at the rate for which it was designed.
- Do not use the power tool if the switch does not turn it on and off.** Any power tool that cannot be controlled with the switch is dangerous and must be repaired.

- c) **Disconnect the plug from the power source and/ or remove the battery pack, if detachable, from the power tool before making any adjustments, changing accessories, or storing power tools.** Such preventive safety measures reduce the risk of starting the power tool accidentally.
- d) **Store idle power tools out of the reach of children and do not allow persons unfamiliar with the power tool or these instructions to operate the power tool.** Power tools are dangerous in the hands of untrained users.
- e) **Maintain power tools and accessories. Check for misalignment or binding of moving parts, breakage of parts and any other condition that may affect the power tool's operation. If damaged, have the power tool repaired before use.** Many accidents are caused by poorly maintained power tools.
- f) **Keep cutting tools sharp and clean.** Properly maintained cutting tools with sharp cutting edges are less likely to bind and are easier to control.
- g) **Use the power tool, accessories and tool bits, etc. in accordance with these instructions, taking into account the working conditions and the work to be performed.** Use of the power tool for operations different from those intended could result in a hazardous situation.
- h) **Keep handles and grasping surfaces dry, clean and free from oil and grease.** Slippery handles and grasping surfaces do not allow for safe handling and control of the tool in unexpected situations.

5) Battery Tool Use and Care

- a) **Recharge only with the charger specified by the manufacturer.** A charger that is suitable for one type of battery pack may create a risk of fire when used with another battery pack.
- b) **Use power tools only with specifically designated battery packs.** Use of any other battery packs may create a risk of injury and fire.
- c) **When battery pack is not in use, keep it away from other metal objects, like paper clips, coins, keys, nails, screws or other small metal objects, that can make a connection from one terminal to another.** Shorting the battery terminals together may cause burns or a fire.
- d) **Under abusive conditions, liquid may be ejected from the battery; avoid contact. If contact accidentally occurs, flush with water. If liquid contacts eyes, additionally seek medical help.** Liquid ejected from the battery may cause irritation or burns.
- e) **Do not use a battery pack or tool that is damaged or modified.** Damaged or modified batteries may exhibit unpredictable behaviour resulting in fire, explosion or risk of injury.
- f) **Do not expose a battery pack or tool to fire or excessive temperature.** Exposure to fire or temperature above 130 °C may cause explosion.
- g) **Follow all charging instructions and do not charge the battery pack or tool outside the temperature range specified in the instructions.** Charging

improperly or at temperatures outside the specified range may damage the battery and increase the risk of fire.

6) Service

- a) **Have your power tool serviced by a qualified repair person using only identical replacement parts.** This will ensure that the safety of the power tool is maintained.
- b) **Never service damaged battery packs.** Service of battery packs should only be performed by the manufacturer or authorised service providers.

Belt Sander Supplemental Safety Warnings

- Always use proper eye protection and a respirator when sanding.
- Use clamps or another practical way to secure and support the workpiece to a stable platform. Holding the workpiece by hand or against your body leaves it unstable and may lead to loss of control.
- Sanding of lead-based paint is not recommended. See **Sanding Lead-Based Paint** for additional information before sanding paint.
- Clean your tool out periodically.
- **Do not wet sand with this sander.** Liquids may enter the motor housing and cause damage to the belt sander.
- Static shocks are possible in dry areas or when the relative humidity of the air is low. This is only temporary and does not affect the use of the belt sander. To reduce the frequency of static shocks, add moisture to the air with a console, or installed humidifier.
- **If included with tool, empty dust bag frequently.** Especially when sanding resin-coated surfaces such as polyurethane, varnish, shellac, etc. The accumulation of fine sanding dust particles may self-ignite and cause fire.
- **Do not operate this tool for long periods of time.** Vibration caused by the operating action of this tool may cause permanent injury to fingers, hands, and arms. Use gloves to provide extra cushion, take frequent rest periods, and limit daily time of use.
- **Sanding of lead-based paint, chemically pressure treated lumber or other materials that may contain carcinogens is not recommended.** Sanding of these materials should only be performed by a professional.
- **ALWAYS disconnect tool from the power source before changing abrasive belts.** Such preventive safety measures reduce the risk of starting the power tool accidentally.
- **ALWAYS maintain a firm grip with both hands on the belt sander handles to prevent loss of control.**
- **ALWAYS keep fingers away from the moving belt and areas where the belt enters the housing to avoid severe abrasion.**
- **Do not operate belt sander without all guards and covers securely in place.**
- **To avoid injury, do not use this tool in a stand that would invert it for use as a stationary belt sander.** This tool is not made for that application. Specific Safety Warnings and Instructions: Sanders

Sanding Lead-Based Paint

Sanding of lead-based paint is **NOT RECOMMENDED** due to the difficulty of controlling the contaminated dust. The greatest danger of lead poisoning is to children and pregnant women.

Since it is difficult to identify whether or not a paint contains lead without a chemical analysis, we recommend the following precautions when sanding any paint:

Personal Safety

- No children or pregnant women should enter the work area where the paint sanding is being done until all clean-up is completed.
- A dust mask or respirator should be worn by all persons entering the work area. The filter should be replaced daily or whenever the wearer has difficulty breathing.

NOTE: Only those dust masks suitable for working with lead paint dust and fumes should be used. Ordinary painting masks do not offer this protection. See your local hardware dealer for the proper mask.

- NO EATING, DRINKING or SMOKING should be done in the work area to prevent ingesting contaminated paint particles. Workers should wash and clean up **BEFORE** eating, drinking or smoking. Articles of food, drink, or smoking should not be left in the work area where dust would settle on them.

Environmental Safety

- Paint should be removed in such a manner as to minimize the amount of dust generated.
- Areas where paint removal is occurring should be sealed with plastic sheeting of 4 mils thickness.
- Sanding should be done in a manner to reduce tracking of paint dust outside the work area.

Cleaning and Disposal

- All surfaces in the work area should be vacuumed and thoroughly cleaned daily for the duration of the sanding project. Vacuum filter bags should be changed frequently.
- Plastic drop cloths should be gathered up and disposed of along with any dust chips or other removal debris. They should be placed in sealed refuse receptacles and disposed of through regular trash pick-up procedures. During clean-up, children and pregnant women should be kept away from the immediate work area.
- All toys, washable furniture and utensils used by children should be washed thoroughly before being used again.

Residual Risks

In spite of the application of the relevant safety regulations and the implementation of safety devices, certain residual risks cannot be avoided. These are:

- *Impairment of hearing.*
- *Risk of personal injury due to flying particles.*
- *Risk of burns due to accessories becoming hot during operation.*
- *Risk of personal injury due to prolonged use.*

SAVE THESE INSTRUCTIONS

Chargers

DEWALT chargers require no adjustment and are designed to be as easy as possible to operate.

Electrical Safety

The electric motor has been designed for one voltage only. Always check that the battery pack voltage corresponds to the voltage on the rating plate. Also make sure that the voltage of your charger corresponds to that of your mains.



Your DEWALT charger is double insulated in accordance with IEC60335; therefore, no earth wire is required.

If the supply cord is damaged, it must be replaced only by DEWALT or an authorised service organisation.

Using an Extension Cable

An extension cord should not be used unless absolutely necessary. Use an approved extension cable suitable for the power input of your charger (refer to **Technical Data**). The minimum conductor size is 1 mm²; the maximum length is 30 m. When using a cable reel, always unwind the cable completely.

Important Safety Instructions for All Battery Chargers

SAVE THESE INSTRUCTIONS: This manual contains important safety and operating instructions for compatible battery chargers (refer to **Technical Data**). Before using charger, read all instructions and cautionary markings on charger, battery pack, and product using battery pack.



WARNING: Shock hazard. Do not allow any liquid to get inside charger. Electric shock may result.



WARNING: We recommend the use of a residual current device with a residual current rating of 30 mA or less.



CAUTION: Burn hazard. To reduce the risk of injury, charge only DEWALT rechargeable batteries. Other types of batteries may burst, causing personal injury and damage.



CAUTION: Children should be supervised to ensure that they do not play with the appliance.

NOTICE: Under certain conditions, with the charger plugged into the power supply, the exposed charging contacts inside the charger can be shorted by foreign material. Foreign materials of a conductive nature such as, but not limited to, steel wool, aluminum foil or any buildup of metallic particles should be kept away from charger cavities. Always unplug the charger from the power supply when there is no battery pack in the cavity. Unplug charger before attempting to clean.

- **DO NOT attempt to charge the battery pack with any chargers other than the ones in this manual.** The charger and battery pack are specifically designed to work together.
- **These chargers are not intended for any uses other than charging DEWALT rechargeable batteries.** Any other uses may result in risk of fire, electric shock or electrocution.
- **Do not expose charger to rain or snow.**
- **Pull by plug rather than cord when disconnecting charger.** This will reduce risk of damage to electric plug and cord.

- **Make sure that cord is located so that it will not be stepped on, tripped over, or otherwise subjected to damage or stress.**
- **Do not use an extension cord unless it is absolutely necessary.** Use of improper extension cord could result in risk of fire, electric shock, or electrocution.
- **Do not place any object on top of charger or place the charger on a soft surface that might block the ventilation slots and result in excessive internal heat.** Place the charger in a position away from any heat source. The charger is ventilated through slots in the top and the bottom of the housing.
- **Do not operate charger with damaged cord or plug—** have them replaced immediately.
- **Do not operate charger if it has received a sharp blow, been dropped, or otherwise damaged in any way.** Take it to an authorised service centre.
- **Do not disassemble charger; take it to an authorised service centre when service or repair is required.** Incorrect reassembly may result in a risk of electric shock, electrocution or fire.
- *In case of damaged power supply cord, the supply cord must be replaced immediately by the manufacturer, its service agent or similar qualified person to prevent any hazard.*
- **Disconnect the charger from the outlet before attempting any cleaning. This will reduce the risk of electric shock.** Removing the battery pack will not reduce this risk.
- **NEVER attempt to connect two chargers together.**
- **The charger is designed to operate on standard 220-240V household electrical power. Do not attempt to use it on any other voltage.** This does not apply to the vehicular charger.

Charging a Battery (Fig. B)

NOTE: To ensure maximum performance and life of lithium-ion battery packs, charge the battery pack fully before first use.













1. Plug the charger into an appropriate outlet before inserting battery pack.
2. Insert the battery pack into the charger, making sure the battery pack is fully seated in the charger. The red (charging) light will blink repeatedly indicating that the charging process has started.
3. The Stage 1 Charging blink indicator represents the charge process that charges the majority of the battery's capacity. Stage 2 Charging blink indicator represents the remainder, or top off charge process, for the battery to reach full capacity.
4. The completion of charge for Stage 1 or Stage 2 will be indicated by the Stage's light remaining ON continuously. The battery pack is fully charged when both Stage 1 and Stage 2 Charging lights remain ON continuously, and it may be removed and used at this time or left in the charger.

NOTE: To remove the battery pack, some chargers require the battery pack release button to be pressed.

Charger Operation

Refer to the indicators below for the charge status of the battery pack.

Indicators

	Stage 1 Charging		
	Stage 2 Charging		
	Fully Charged		
	Hot/Cold Pack Delay*		

*The red light will continue to blink, but a yellow indicator light will be illuminated during this operation. Once the battery pack has reached an appropriate temperature, the yellow light will turn off and the charger will resume the charging procedure. The compatible charger(s) will not charge a faulty battery pack. The charger will indicate faulty battery by refusing to light.

NOTE: This could also mean a problem with a charger.

If the charger indicates a problem, take the charger and battery pack to be tested at an authorised service centre.

Hot/Cold Pack Delay

When the charger detects a battery pack that is too hot or too cold, it automatically starts a Hot/Cold Pack Delay, suspending charging until the battery pack has reached an appropriate temperature. The charger then automatically switches to the pack charging mode. This feature ensures maximum battery pack life.

A cold battery pack will charge at a slower rate than a warm battery pack. The battery pack will charge at that slower rate throughout the entire charging cycle and will not return to maximum charge rate even if the battery pack warms.

The DCB118 charger is equipped with an internal fan designed to cool the battery pack. The fan will turn on automatically when the battery pack needs to be cooled. Never operate the charger if the fan does not operate properly or if ventilation slots are blocked. Do not permit foreign objects to enter the interior of the charger.

Electronic Protection System

XR Li-Ion tools are designed with an Electronic Protection System that will protect the battery pack against overloading, overheating or deep discharge.

The tool will automatically turn off if the Electronic Protection System engages. If this occurs, place the lithium-ion battery pack in the charger until it is fully charged.

Wall Mounting

These chargers are designed to be wall mountable or to sit upright on a table or work surface. If wall mounting, locate the charger within reach of an electrical outlet, and away from a corner or other obstructions which may impede air flow. Use the back of the charger as a template for the location of the mounting screws on the wall. Mount the charger securely using drywall screws (purchased separately) at least 25.4 mm long with a screw head diameter of 7–9 mm, screwed into wood to an optimal depth leaving approximately 5.5 mm of the screw exposed. Align the slots on the back of the charger with the exposed screws and fully engage them in the slots.

Charger Cleaning Instructions

 **WARNING: Shock hazard. Disconnect the charger from the AC outlet before cleaning.** Dirt and grease may be removed from the exterior of the charger using a cloth or soft non-metallic brush. Do not use water or any cleaning solutions. Never let any liquid get inside the tool; never immerse any part of the tool into a liquid.

Battery Packs

Important Safety Instructions for All Battery Packs

When ordering replacement battery packs, be sure to include catalogue number and voltage.

The battery pack is not fully charged out of the carton. Before using the battery pack and charger, read the safety instructions below. Then follow charging procedures outlined.

READ ALL INSTRUCTIONS

- **Do not charge or use battery in explosive atmospheres, such as in the presence of flammable liquids, gases or dust.** Inserting or removing the battery from the charger may ignite the dust or fumes.
- **Never force battery pack into charger. Do not modify battery pack in any way to fit into a non-compatible charger as battery pack may rupture, causing serious personal injury.**
- Charge the battery packs only in DEWALT chargers.
- **DO NOT splash or immerse in water or other liquids.**
- **Do not store or use the tool and battery pack in locations where the temperature may fall below 4 °C (39.2 °F) (such as outside sheds or metal buildings in winter), or reach or exceed 40 °C (104 °F) (such as outside sheds or metal buildings in summer).**
- **Do not incinerate the battery pack even if it is severely damaged or is completely worn out.** The battery pack can explode in a fire. Toxic fumes and materials are created when lithium-ion battery packs are burned.
- **If battery contents come into contact with the skin, immediately wash area with mild soap and water.** If battery liquid gets into the eye, rinse water over the open eye for 15 minutes or until irritation ceases. If medical attention is needed, the battery electrolyte is composed of a mixture of liquid organic carbonates and lithium salts.
- **Contents of opened battery cells may cause respiratory irritation.** Provide fresh air. If symptoms persist, seek medical attention.

 **WARNING: Burn hazard.** Battery liquid may be flammable if exposed to spark or flame.

 **WARNING: Never attempt to open the battery pack for any reason.** If battery pack case is cracked or damaged, do not insert into charger. Do not crush, drop or damage battery pack. Do not use a battery pack or charger that has received a sharp blow, been dropped, run over or damaged in any way (i.e., pierced with a nail, hit with a hammer, stepped on). Electric shock or electrocution may result. Damaged battery packs should be returned to service centre for recycling.

 **WARNING: Fire hazard. Do not store or carry the battery pack so that metal objects can contact exposed battery terminals.** For example, do not place the battery pack in aprons, pockets, tool boxes, product kit boxes, drawers, etc., with loose nails, screws, keys, etc.

 **CAUTION: When not in use, place tool on its side on a stable surface where it will not cause a tripping or falling hazard.** Some tools with large battery packs will stand upright on the battery pack but may be easily knocked over.

Transportation

 **WARNING: Fire hazard.** Transporting batteries can possibly cause fire if the battery terminals inadvertently come into contact with conductive materials. When transporting batteries, make sure that the battery terminals are protected and well-insulated from materials that could contact them and cause a short circuit. **NOTE:** Lithium-ion batteries should not be put in checked baggage.

DEWALT batteries comply with all applicable shipping regulations as prescribed by industry and legal standards, which include UN Recommendations on the Transport of Dangerous Goods; International Air Transport Association (IATA) Dangerous Goods Regulations; International Maritime Dangerous Goods (IMDG) Regulations; and the European Agreement Concerning The International Carriage of Dangerous Goods by Road (ADR). Lithium-ion cells and batteries have been tested to section 38.3 of the UN Recommendations on the Transport of Dangerous Goods Manual of Tests and Criteria.

In most instances, shipping a DEWALT battery pack will be excepted from being classified as a fully regulated Class 9 Hazardous Material. In general, only shipments containing a lithium-ion battery with an energy rating greater than 100 Watt Hours (Wh) will require being shipped as fully regulated Class 9. All lithium-ion batteries have the Wh rating marked on the pack. Furthermore, due to regulation complexities, DEWALT does not recommend air shipping lithium-ion battery packs alone regardless of Wh rating. Shipments of tools with batteries (combo kits) can be air shipped as excepted if the Wh rating of the battery pack is no greater than 100 Wh.

Regardless of whether a shipment is considered excepted or fully regulated, it is the shipper's responsibility to consult the latest regulations for packaging, labeling/marketing and documentation requirements.

The information provided in this section of the manual is provided in good faith and believed to be accurate at the time the document was created. However, no warranty, expressed or implied, is given. It is the buyer's responsibility to ensure that its activities comply with the applicable regulations.

Transporting the FLEXVOLT™ Battery

The DEWALT FLEXVOLT® battery has two modes: **Use** and **Transport**.

Use Mode: When the FLEXVOLT™ battery stands alone or is in a DEWALT 18V (20V Max) product, it will operate as an 18V (20V Max) battery. When the FLEXVOLT™ battery is in a 54V

(60V Max) or a 108V (120V Max) (two 54V (60V Max) batteries) product, it will operate as a 54V (60V Max) battery.

Transport Mode: When the cap is attached to the FLEXVOLT™ battery, the battery is in Transport mode. Keep the cap for shipping.

When in Transport mode, strings of cells are electrically disconnected within the pack, resulting in 3 batteries with a lower Watt hour (Wh) rating as compared to 1 battery with a higher Watt hour rating. This increased quantity of 3 batteries with the lower Watt hour rating can exempt the pack from certain shipping regulations that are imposed upon the higher Watt hour batteries.

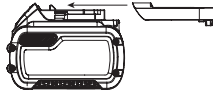

For example, the Transport Wh rating might indicate 3 x 36 Wh, meaning 3 batteries of 36 Wh each.

Example of Use and Transport Label Marking



The Use Wh rating might indicate 108 Wh (1 battery implied).







Storage Recommendations

1. The best storage place is one that is cool and dry away from direct sunlight and excessive heat or cold. For optimum battery performance and life, store battery packs at room temperature when not in use.
2. For long storage, it is recommended to store a fully charged battery pack in a cool, dry place out of the charger for optimal results.

NOTE: Battery packs should not be stored completely depleted of charge. The battery pack will need to be recharged before use.

Labels on Charger and Battery Pack

In addition to the pictographs used in this manual, the labels on the charger and the battery pack may show the following pictographs:

-  Read instruction manual before use.
-  Refer to **Technical Data** for charging time.
-  Do not probe with conductive objects.
-  Do not charge damaged battery packs.
-  Do not expose to water.
-  Have defective cords replaced immediately.
-  Charge only between 4 °C and 40 °C.

 Only for indoor use.

 Discard the battery pack with due care for the environment.

 Charge DeWALT battery packs only with designated DeWALT chargers. Charging battery packs other than the designated DeWALT batteries with a DeWALT charger may make them burst or lead to other dangerous situations.

 Do not incinerate the battery pack.

 USE (without transport cap). Example: Wh rating indicates 108 Wh (1 battery with 108 Wh).

 TRANSPORT (with built-in transport cap). Example: Wh rating indicates 3 x 36 Wh (3 batteries of 36 Wh).

Battery Type

Refer to **Technical Data** for more information.

Package Contents

The package contains:

- 1 Bandfile
- 2 80 Grit Abrasive Belt
- 1 Instruction manual
- 1 Side Handle

NOTE: Battery packs, chargers and kitboxes are not included with N models. Battery packs and chargers are not included with NT models. B models include Bluetooth® battery packs.

NOTE: The Bluetooth® word mark and logos are registered trademarks owned by the Bluetooth® SIG, Inc. and any use of such marks by DeWALT is under license. Other trademarks and trade names are those of their respective owners.

- Check for damage to the tool, parts or accessories which may have occurred during transport.
- Take the time to thoroughly read and understand this manual prior to operation.

Markings on Tool

The following pictographs are shown on the tool:

-  Read instruction manual before use.
-  Wear ear protection.
-  Wear eye protection.
-  Wear respiratory protection
-  Visible radiation. Do not stare into light.
-  Hot surface. Risk of burns. Do not touch.



Warning

Date Code Position (Fig. A)

The production date code **15** consists of a 4-digit year followed by a 2-digit week and is extended by a 2-digit factory code.

Description (Fig. A)



WARNING: Never modify the power tool or any part of it. Damage or personal injury could result.

- 1 Variable speed dial
- 2 Variable speed trigger
- 3 Lock-off button
- 4 Main handle
- 5 Side handle
- 6 Belt tensioning lever
- 7 Belt tracking screw
- 8 Straight arm
- 9 Lock lever
- 10 Dust shroud(sold separately)
- 11 Dust port
- 12 Rotatable LED light
- 13 Battery pack
- 14 Battery release button
- 15 Date code

Intended Use

This bandfile is designed for sanding wood, metal, plastic and painted surfaces.

For optimal balance, use 5Ah battery or smaller.

DO NOT use under wet conditions or in the presence of flammable liquids or gases.

This bandfile is a professional power tool.

DO NOT let children come into contact with the tool.

Supervision is required when inexperienced operators use this tool.

- **Young children and the infirm.** This appliance is not intended for use by young children or infirm persons without supervision.
- This product is not intended for use by persons (including children) suffering from diminished physical, sensory or mental abilities; lack of experience, knowledge or skills unless they are supervised by a person responsible for their safety. Children should never be left alone with this product.

ASSEMBLY AND ADJUSTMENTS



WARNING: To reduce the risk of serious personal injury, turn tool off and disconnect battery pack before making any adjustments or removing/installing attachments or accessories. An accidental start-up can cause injury.



WARNING: Use only DEWALT batteries and chargers.

Inserting and Removing the Battery Pack from the Tool (Fig. B)

NOTE: Make sure your battery pack **13** is fully charged.

To Install the Battery Pack into the Tool Handle

1. Align the battery pack with the rails inside the tool's handle (Fig. B).
2. Slide it into the handle until the battery pack is firmly seated in the tool and ensure that you hear the lock snap into place.

To Remove the Battery Pack from the Tool

1. Press the battery release button **14** and firmly pull the battery pack out of the tool handle.
2. Insert battery pack into the charger as described in the charger section of this manual.

Fuel Gauge Battery Packs (Fig. B)

Some DEWALT battery packs include a fuel gauge, which consists of three green LED lights that indicate the level of charge remaining in the battery pack.

To actuate the fuel gauge, press and hold the fuel gauge button **16**. A combination of the three green LED lights will illuminate, designating the level of charge left. When the level of charge in the battery is below the usable limit, the fuel gauge will not illuminate and the battery will need to be recharged.

NOTE: The fuel gauge is only an indication of the charge left on the battery pack. It does not indicate tool functionality and is subject to variation based on product components, temperature and end-user application.

Fitting and Removing Sanding Arms (Fig. C, D)

13 mm x 457 mm (1/2" x 18") width belts can be installed with the optional arms that are designed for the corresponding belt widths.

Your tool is supplied a straight arm **8** (sanding width 13 mm); the offset arm **17** (sanding width 13 mm) is sold separately as attachment, contact with local service for more information.

NOTE: Your tool comes with the straight arm already assembled.

Fitting

1. Make sure that the belt tensioning lever **6** is in the position shown in Fig. C.
2. Loosen and remove the belt tracking screw **7**.
3. Check that the spring **18** is located in its mounting hole.
4. Position the arm **8** or **17** as shown.
5. Fit the belt tracking screw and tighten it until the arm is aligned with the tool.

Removing

1. Remove the sanding belt **20** (if present) as described in the **Fitting and Removing Sanding Belts** section.
2. Loosen and remove the belt tracking screw **7**.
3. Remove the arm **8** or **17**.



WARNING! Be careful not to lose the spring.



WARNING: DO NOT touch the sanding arms after working as a high temperature may cause injury.

Fitting and Removing Sanding Belts (Fig. D, E1–E3)



WARNING! The spring must be fitted. Be careful not to lose the spring.

Fitting

1. Pull the belt tensioning lever **6** back.
2. Make sure that the arrows on the inside of the sanding belt **20** face the same direction as the arrow **19** on the housing.
3. Place the sanding belt over the rear pulley **22** first. The sanding belt should be placed under the shoulder **29** (Fig. E1, E2), then hook the other side over the front pulley **21**.
4. Move the belt tensioning lever to its original forward position.
5. Adjust the belt tracking as described in the Adjusting the Sanding Belt Tracking section.

NOTE: The sanding belt should not ride on the shoulder of the rear pulley (Fig. E3). Be sure to place the sanding belt under the shoulder.

NOTE: The area surrounding the rear pulley **22** must be cleaned after each use due to the risk of gathering dust.

Removing

1. Pull the belt tensioning lever **6** back to release the tension on the belt.
2. Slide the sanding belt **20** off the pulleys.

Adjusting the Sanding Belt Tracking (Fig. C, D, F, G)

1. Make sure that the sanding belt **20** is properly aligned with the straight arm **8**.
2. Switch the tool on and do a trial run at low speed.
3. Turn the belt tracking screw **7** clockwise to move belt to right, or counterclockwise to move belt to left until the sanding belt runs straight along the length of the arm.

Adjusting the Arm Inclination (Fig. K, L)

The straight arm **8** or offset arm **17** can pivot and be fixed at any desired angle within the range A (102 °) as shown in Fig. L. Make a comfortable working position by adjusting the angle.

1. Loosen the lock lever **9** by flipping it downwards.
2. Pivot the arm to the desired position.
3. Secure the position of the arm firmly by flipping the lock lever up.

Attaching the Side Handle (Fig. H)



WARNING: This handle SHOULD BE USED AT ALL TIMES to maintain complete control of the tool. Always make sure the handle is tight.

Screw the side handle **5** tightly into the threaded mounting hole of the filehead body **23**.

Attaching the Dust Shroud (Fig. H)

The DCM200DC Dust Shroud (sold separately) is included with this tool. This accessory connects to the tool's filehead body. To attach the dust shroud **10**, FIRST disconnect the battery from the tool.

1. Place the ribs **24** of the dust shroud **10** along the groove of the filehead body **23**.
2. Position the dust port **11** against the filehead body to let the dust port hole align with the filehead body hole.
3. Use the side handle **5** to tighten the dust shroud to the filehead body.

Attaching a Dust Extractor to the Dust Shroud (Fig. P, Q)



WARNING: Do not attach the dust port and connect the dust extractor when grinding or sanding metals.



WARNING: Risk of dust inhalation. To reduce the risk of personal injury, **ALWAYS** wear an approved dust mask.



WARNING: Collected sanding dust from sanding surface coatings (polyurethane, linseed oil, etc.) can self-ignite in dust extractor or elsewhere and cause fire. To reduce risk, strictly follow sander manual and coating manufacturer's instructions.

The DCM200DC dust shroud is compatible with the DWH161 DEWALT Universal Dust Extractor (sold separately).

- Friction-fit the dust port **11** to the hose **25** of the DWH161 Universal Dust Extractor.

If available, the DWV9170 adaptor **30** can be used to connect your tool to the DEWALT AirLock™ connection system (sold separately).

1. Push the AirLock™ connector **31** onto the DWV9170 adaptor.
2. Friction-fit the DWV9170 adaptor to the dust port.

OPERATION

Instructions for Use



WARNING: Always observe the safety instructions and applicable regulations.



WARNING: To reduce the risk of serious personal injury, turn tool off and disconnect battery pack before making any adjustments or removing/installing attachments or accessories. An accidental start-up can cause injury.



WARNING: DO NOT touch the filehead body during use as a high temperature may cause injury.

Proper Hand Position (Fig. J)



WARNING: To reduce the risk of serious personal injury, **ALWAYS** use proper hand position as shown.



WARNING: To reduce the risk of serious personal injury, **ALWAYS** hold securely in anticipation of a sudden reaction.

Proper hand position requires one hand on the main handle **4** and one hand on the side handle **5**.

LED Worklight (Fig. A, N)



CAUTION: Do not stare into the LED worklight.

Serious eye injury could result.

The rotatable LED worklight **12** can be adjusted at three levels through an angle of 60°. When the tool is activated by depressing the variable speed trigger **2**, the rotatable LED worklight will automatically turn on. The rotatable LED worklight will turn off 20 seconds after the variable speed trigger has been released.

NOTE: Be careful not to scratch the lens of the worklight as loss of illumination may occur. Use a dry cloth to wipe dirt off the lens of the worklight.

Variable Speed Dial (Fig. O)

The variable speed dial **1** allows you to adapt the speed of the tool to the workpiece material.

The tool speed can be adjusted between 1 to 7.

Use a low speed setting when using a fine grit, when working with plastics or ceramics and when removing painted or varnished surfaces.

Use a high speed setting when using a coarse grit and when removing a lot of material.

- Set the variable speed dial **1** to the required setting.

Switching On and Off (Fig. A)



CAUTION: DO NOT pull the variable speed trigger hard without first unlocking the tool. Refer to the **Lock-off Button** section. This can cause a breakage to the variable speed trigger.

1. To start the tool, pull the variable speed trigger **2**.
2. To turn the tool off, release the variable speed trigger.

Lock-off Button (Fig. I)



WARNING: To prevent accidental start-up, this tool is equipped with a lock-off button.

1. To lock the tool, depress the lock-off button **3** to the locked position. When the lock-off button is in the locked position, the tool is locked and the variable speed trigger **2** cannot be pulled.
2. To unlock the tool, depress the lock-off button **3** to the unlocked position.

NOTE: The tool is locked and the speed trigger can't be pulled while the arm is being pivoted to the storage position (beyond 102°).

Special Applications (Fig. A, R–V)



WARNING: To reduce the risk of fire or serious injury, avoid sanding ignitable materials such as aluminum and magnesium.



WARNING! Do not allow bystanders in front of the tool while in operation as there may be a risk of the sanding belt breaking and dislodging from the arm.

Straight Arm (Fig. R–U)

Use the straight arm **8** for general use, sanding, deburring, and slotting. Work should always be performed within range (A) of

the front pulley **21** (Fig. R) or within range (B) of the platen **32**, as shown on the straight arm (Fig. R).

- Refer to area C of the straight arm (Fig. S) for sanding in confined areas.
- Refer to areas D and E of the straight arm (Fig. T, U) for general sanding.

Offset Arm (Fig. V)

Where Supplied

- Use the offset arm **17** for sanding curved surfaces.
 - Refer to area F (Fig. V) of the offset arm for sanding a curved surface.

Hints for Optimum Use

- Always hold the tool with both hands.
- Do not exert too much pressure on the tool.
- For best belt life, sand only with the bottom side of belt.
- Do not exert much force in line with the arm.
- Regularly check the condition of the sanding belt **20**. Replace when necessary.
- Always sand with the grain of the wood.
- When sanding new layers of paint before applying another layer, use extra fine grit.
- Consult your retailer for more information on available accessories.

MAINTENANCE

Your power tool has been designed to operate over a long period of time with a minimum of maintenance. Continuous satisfactory operation depends upon proper tool care and regular cleaning.



WARNING: To reduce the risk of serious personal injury, turn tool off and disconnect battery pack before making any adjustments or removing/installing attachments or accessories. An accidental start-up can cause injury.

The charger and battery pack are not serviceable.

Tool Connect™ Chip (Fig. W)



WARNING: To reduce the risk of serious personal injury, turn unit off and remove the battery pack before making any adjustments or removing/installing attachments or accessories. An accidental start-up can cause injury.

Your tool is Tool Connect™ Chip ready and has a location for installation of a Tool Connect™ Chip.

Tool Connect™ Chip is an optional application for your smart device (such as a smart phone or tablet) that connects the device to utilize the mobile application for inventory management functions.

Refer to **Tool Connect™ Chip Instruction Sheet** for more information.

Installing the Tool Connect™ Chip

1. Remove the retaining screws **26** that hold the Tool Connect™ Chip protective cover **27** into the tool.

- Remove the protective cover and insert the Tool Connect™ Chip into the empty pocket **28**.
- Ensure that the Tool Connect™ Chip is flush with the housing. Secure it with the retaining screws and tighten the screws.
- Refer to **Tool Connect™ Chip Instruction Sheet** for further instructions.

Storage (Fig. K–M)



CAUTION: Be careful not to pinch your fingers when moving the straight arm. Failure to do so may cause personal injury.

The straight arm **8** can be folded up to save on storage space as shown in Fig. M. The straight arm can move through an angle of up to 172 °.

- Loosen the lock lever **9** by flipping it down. Pivot the arm at an angle of 102 °.
- Push the lock-off button **3**, and then adjust the angle of the straight arm in the range B (102 ° to 172 °) shown in Fig. L.
- Secure the lock lever by flipping it up to fix the arm.

NOTE: The tool is locked and the speed trigger can't be pulled while the arm is being pivoted to the storage position (beyond 102 °).

Lubrication

Your power tool requires no additional lubrication.

Cleaning



WARNING: Electrical shock and mechanical hazard. Disconnect the electrical appliance from the power source before cleaning.



WARNING: To ensure safe and efficient operation, always keep the electrical appliance and the ventilation slots clean.



WARNING: Never use solvents or other harsh chemicals for cleaning the non-metallic parts of the tool. These chemicals may weaken the materials used in these parts. Use a cloth dampened only with water and mild soap. Never let any liquid get inside the tool; never immerse any part of the tool into a liquid.

Ventilation slots can be cleaned using a dry, soft non-metallic brush and/or a suitable vacuum cleaner. Do not use water or any cleaning solutions. Wear approved eye protection and an approved dust mask.

Optional Accessories



WARNING: Since accessories, other than those offered by DEWALT, have not been tested with this product, use of such accessories with this tool could be hazardous. To reduce the risk of injury, only DEWALT-recommended accessories should be used with this product.

Consult your dealer for further information on the appropriate accessories.

Protecting the Environment

Separate collection. Products and batteries marked with this symbol must not be disposed of with normal household waste.



Products and batteries contain materials that can be recovered or recycled, reducing the demand for raw materials. Please recycle electrical products and batteries according to local provisions. Further information is available at www.2helpU.com.

Rechargeable Battery Pack

This long-life battery pack must be recharged when it fails to produce sufficient power on jobs that were easily done before. At the end of its technical life, discard it with due care for our environment:

- Run the battery pack down completely, then remove it from the tool.
- Li-Ion cells are recyclable. Take them to your dealer or a local recycling station. The collected battery packs will be recycled or disposed of properly.

After Service and Repair

DEWALT service centers are staffed with trained personnel to provide customers with efficient and reliable product service. We do not take any responsibility when you have repaired in unauthorized service center. You can refer to the leaflet of CONTACT CENTER LOCATOR in product package and contact us through hotline, website or social media to find the nearest DEWALT service center around you.

锂电无刷砂带机

DCM200

恭喜!

您选择了本款DEWALT工具。凭借多年的产品开发和创新能力，DEWALT已经成为专业电动工具用户最可靠的合作伙伴之一。

技术数据

			DCM200
电压	V_{DC}		18(20 最大)
电池包类型			锂离子
空载转速	m/min		600–1700
砂带尺寸	mm		13 x 457
重量(不含电池包)	kg		1.3

电池				充电器 / 充电时间 (分钟)***		
型号	V_{DC}	电池容量 (Ah)	重量 (kg)	DCB112	DCB115	DCB118
				DCB1102	DCB1104	
DCB606	18/54 (最大 20/60)	6.0/2.0	1.05	170	90	60
DCB609/DCB609G	18/54 (最大 20/60)	9.0/3.0	1.46	270	135*	75*
DCB612	18/54 (最大 20/60)	12.0/4.0	1.44	350	180	120
DCB182	18 (最大 20)	4.0	0.61	120	60	60/40**
DCB203	18 (最大 20)	2.0	0.40	60	30	30
DCB184/DCB184G	18 (最大 20)	5.0	0.62	150	75	75/50**
DCB208	18 (最大 20)	8.0	0.95	240	120	70
DCBP034	18 (最大 20)	1.7	0.32	50	27	27
DCBP520	18 (最大 20)	5.0	0.75	150	75	75/50**

*日期码 201811475B 或以后

**日期码 201536 或以后

***电池包充电时间表仅供参考；实际充电时间将根据电池包的温度和状况而变化。



警告:为降低伤害风险, 请阅读使用手册。

定义:安全指南

下列定义描述了各标志术语的严重程度。请仔细阅读本手册, 并注意这些标志。



危险:表示存在紧急危险情况, 如果不加以避免, 将导致死亡或严重伤害。



警告:表示存在潜在的危險情况, 如果不加以避免, 可能导致死亡或严重伤害。



小心:表示存在潜在危险情况, 如果不加以避免, 可能导致轻度或中度伤害。

注意:表示存在不涉人身伤害的情况, 如果不加以避免, 可能导致财产损失。



表示存在触电风险。



表示存在火灾风险。

电动工具通用安全警告



警告：请阅读本电动工具随附的所有安全警告、说明、图示和规定。未能遵照以下所列说明会导致电击、火灾和/或严重伤害。

保存所有警告和说明书以备查阅。

警告中的术语“电动工具”指市电驱动(有线)电动工具或电池驱动(无线)电动工具。

1) 工作场地的安全

- a) 保持工作场地清洁和明亮。杂乱和黑暗的场地会引发事故。
- b) 不要在易爆环境, 如有易燃液体、气体或粉尘的环境下操作电动工具。电动工具产生的火花会点燃粉尘或气体。
- c) 操作电动工具时, 远离儿童和旁观者。注意力不集中会使你失去对工具的控制。

2) 电气安全

- a) 电动工具插头必须与插座相配。绝不能以任何方式改装插头。需接地的电动工具不能使用任何转换插头。未经改装的插头和相配的插座将降低电击风险。
- b) 避免人体接触接地表面, 如管道、散热片和冰箱。如果你身体接触接地表面会增加电击风险。
- c) 不得将电动工具暴露在雨中或潮湿环境中。水进入电动工具将增加电击风险。
- d) 不得滥用电源线。绝不能用电源线搬运、拉动电动工具或拔出其插头。使电源线远离热源、油、锐边或运动部件。受损或缠绕的电源线会增加电击风险。
- e) 当在户外使用电动工具时, 使用适合户外使用的延长线。适合户外使用的电线将降低电击风险。
- f) 如果无法避免在潮湿环境中操作电动工具, 应使用带有剩余电流装置(RCD)保护的电源。RCD的使用可降低电击风险。

3) 人身安全

- a) 保持警觉, 当操作电动工具时关注所从事的操作并保持清醒。当你感到疲倦, 或在有药物、酒精或治疗反应时, 不要操作电动工具。在操作电动工具时瞬间的疏忽会导致严重人身伤害。
- b) 使用个人防护设备。始终佩戴护目镜。诸如适当条件下使用防尘面具、防滑安全鞋、安全帽、听力防护等装置能减少人身伤害。
- c) 防止意外启动。在连接电源和/或电池包、拿起或搬运工具前, 应确保开关处于关断位置。手指放在开关上搬运工具或开关处于接通时通电会导致危险。
- d) 在电动工具接通之前, 拿掉所有调节钥匙或扳手。遗留在电动工具旋转零件上的扳手或钥匙会导致人身伤害。
- e) 请勿过分伸展。时刻注意立足点和身体平衡。这样能在意外情况下能更好地控制住电动工具。
- f) 着装适当。不要穿宽松衣服或佩戴饰品。让你的头发和衣服远离运动部件。宽松衣服、配饰或长发可能会卷入运动部件。

- g) 如果提供了与排屑、集尘设备连接用的装置, 要确保其连接完好且使用得当。使用集尘装置可降低尘屑引起的危险。
- h) 不要因为频繁使用工具而产生的熟悉感而掉以轻心, 忽视工具的安全准则。某个粗心的动作可能瞬间导致严重的伤害。

4) 电动工具使用和注意事项

- a) 切勿强制使用电动工具。根据用途使用合适的电动工具。选用合适的按照额定值设计的电动工具会使你工作更有效、更安全。
- b) 如果开关不能接通或关断电源, 则不能使用该电动工具。不能通过开关来控制的电动工具是危险的且必须进行修理。
- c) 在进行任何调节、更换附件或贮存电动工具之前, 必须从电源上拔掉插头和/或卸下电池包(如可拆卸)。这种防护性的安全措施降低了电动工具意外启动的风险。
- d) 将闲置不用的电动工具贮存在儿童所及范围之外, 并且不允许不熟悉电动工具和不了解这些说明的人操作电动工具。电动工具在未经培训的使用者手中是危险的。
- e) 维护电动工具及其附件。检查运动部件是否调整到位或卡住, 检查零件破损情况和影响电动工具运行的其他状况。如有损坏, 应在使用前修理好电动工具。许多事故是由维护不良的电动工具引发的。
- f) 保持切削刀具锋利和清洁。维护良好地有锋利切削刃的刀具不易卡住而且容易控制。
- g) 按照使用说明, 并考虑作业条件和要进行的作业来选择电动工具、附件和工具的刀头等。将电动工具用于那些与其用途不符的操作可能会导致危险情况。
- h) 保持手柄和握持表面干燥、清洁, 不得沾有油脂。在意外的情况下, 湿滑的手柄不能保证握持的安全和对工具的控制。

5) 电池式工具使用和注意事项

- a) 仅使用生产者规定的充电器充电。将适用于某种电池包的充电器用到其他电池包时可能会发生着火危险。
- b) 仅使用配有专用电池包的电动工具。使用其他电池包可能会产生伤害和着火危险。
- c) 当电池包不用时, 将它远离其他金属物体, 例如回形针、硬币、钥匙、钉子、螺钉或其他小金属物体, 以防电池包一端与另一端连接。电池包端部短路会引起燃烧或着火。
- d) 在滥用条件下, 液体可能会从电池包中溅出, 应避免接触。如果意外碰到液体, 用水冲洗。如果液体碰到了眼睛, 还应寻求医疗帮助。从电池中溅出的液体可能会发生腐蚀或燃烧。
- e) 不要使用损坏或改装过的电池包或工具。损坏或改装过的电池包可能呈现无法预测的结果, 导致着火、爆炸或伤害。
- f) 不要将电池包暴露于火或高温中。电池包暴露于火或高于130°C的高温中可能会发生爆炸。
- g) 请遵循所有充电说明, 请勿在说明中规定的温度范围以外的环境对电池包或工具充电。不当或在

指定范围以外的温度下充电,可能导致电池损坏并增加火灾风险。

6) 维修

- 让专业维修人员使用相同的备件维修电动工具。这将保证所维修的电动工具的安全。
- 切勿维修损坏的电池包。电池包仅能由生产者或其授权的维修服务商进行维修。

带式砂光机补充安全警告

- 砂磨时一定要使用适用的护目镜和呼吸器。
- 使用夹具或其他切实可行的方法,将工件固定并支撑在稳定的平台上。用手扶住或用身体顶住工件会使其不稳定,可能导致失控。
- 不建议砂磨含铅油漆。有关砂磨涂料前的其他信息,请参阅**砂磨含铅油漆**。
- 定期清理工具。
- **不要用该砂光机进行湿砂光。**液体可能会进入电机外壳,导致砂光机损坏。
- 在干燥地区或空气相对湿度较低时,可能会出现静电冲击。该影响具有一过性,不影响带式砂光机的使用。为减少静电冲击的频率,请利用控制台或安装的加湿器增加空气湿度。
- **如果工具附带集尘袋,请经常清空集尘袋。**特别是在砂磨聚氨酯、清漆、虫胶等树脂涂层表面时。细小的砂磨粉尘颗粒积聚在一起可能会自燃并引发火灾。
- **请勿长时间操作本工具。**本工具的操作动作引起的振动可能对手指、手掌和手臂造成永久性伤害。使用手套提供额外的缓冲,经常休息,并限制每天的使用时间。
- **不建议砂磨含铅油漆、经过化学压力处理的木材或其他可能含有致癌物质的材料。**只有专业人员才能砂磨这些材料。
- **更换砂带前,始终要断开工具与电源的连接。**这种防护性的安全措施降低了电动工具意外起动的风险。
- **始终双手紧握砂带机手柄,以防失控。**
- **始终让手指远离移动的砂带和砂带进入机壳的区域,以避免严重磨损。**
- **请勿在所有防护装置和盖子未牢固安装的情况下操作砂带机。**
- **为避免伤害,请勿将本工具倒置在支架上作为固定式砂带机使用。**本工具不是为这种应用而制造的。特殊安全警告和说明:砂光机

砂磨含铅油漆

由于难以控制脏污的灰尘,因此不建议使用砂纸砂磨含铅油漆。铅中毒对儿童和孕妇的危害最大。由于不进行化学分析很难确定油漆是否含铅,因此我们建议在砂磨任何油漆时采取以下预防措施:

人身安全

- 在所有清理工作完成之前,儿童或孕妇不得进入正在砂磨油漆的工作区域。

- 所有进入工作区域的人员都应佩戴防尘口罩或呼吸器。过滤器应每天更换,或在佩戴者呼吸困难时更换。

注意:只能使用适合处理含铅油漆粉尘和烟雾的防尘面具。普通喷漆面具无法提供这种保护。请咨询您当地的硬件经销商,以获取合适面具。

- 不得在工作区域饮食或吸烟,以防止吸入被污染的油漆颗粒。工作人员在饮食或吸烟之前应该进行洗手和清理。不应将食品、饮料或吸烟物品留在工作区,否则会落满灰尘。

环境安全

- 应以尽量减少灰尘的方式清除油漆。
- 发生脱漆的区域应该用厚度4密耳的塑料薄膜密封。
- 砂磨时应减少工作区域外油漆粉尘的痕迹。

清洁和处理

- 在砂磨项目期间,应对工作区域的所有表面每天进行吸尘和彻底清洁。真空滤袋应经常更换。
- 应将塑料抹布收集起来,与任何灰尘碎片或其他清除碎片一同处理。应将其放在密封的垃圾箱中,并通过常规的垃圾收集程序进行处理。清理过程中,儿童和孕妇应远离直接工作区域。
- 儿童使用的所有玩具、可洗家具和用具在再次使用前应彻底清洗。

剩余风险

尽管遵守了相关的安全法规并采用了安全装备,某些剩余风险仍然是无法避免的。这些风险包括:

- 听力损伤。
- 飞溅颗粒造成的人身伤害风险。
- 使用时附件发热导致的灼伤风险。
- 长时间使用引起的人身伤害风险。

请妥善保管好这些说明

充电器

DeWALT充电器无需做出任何调整,专为简易操作而设计。

电气安全

电机只适用一种工作电压。请务必检查电池包的电压是否和铭牌上的电压一致。请务必检查充电器的电压是否和电源上的电压一致。



DeWALT充电器符合IEC60335双重绝缘要求,因此无需使用接地线。

如果电源线损坏,必须仅由DeWALT或授权的维修机构负责更换。

使用延长线

除非绝对必要,否则请勿使用延长线。使用适合您的充电器输入功率的合格延长线(请参阅**技术数据**)。最小的导线尺寸为1平方毫米;最大长度为30米。使用电缆卷筒时,请务必拉出所有的电缆。

针对所有电池充电器的安全说明

请妥善保管好这些说明:本手册包含重要的兼容电池充电器安全和操作说明(请参阅**技术数据**)。在使用充电器之前,请先阅读所有说明以及充电器、电池包和使用电池包的产品上的警告标记。

警告: 电击危险。请勿让任何液体进入充电器, 否则可能会导致触电。

警告: 我们建议使用漏电保护额定电流为30毫安或以下的漏电保护装置。

小心: 烧伤危险。为降低人身伤害风险, 请仅使用 DEWALT 充电式电池充电。使用其它类型的电池包可能会引起爆裂, 并导致人身伤害和损害。

小心: 应看管好儿童, 以确保他们不将此设备当做玩具来玩。

注意: 在某些情况下, 当充电器的插头插入电源插座时, 充电器内部裸露的充电接触点可能因为外来物件而短路。请勿让能导电的异物靠近充电器腔, 这些外来物件包括但不限于钢棉、铝箔或任何金属颗粒的堆积物。充电器内没有电池包时, 请断开充电器与电源的连接。清洗前, 务必拔掉充电器。

- 请勿试图使用本手册指定的充电器以外的其他任何充电器为电池包充电。充电器和电池包都是专门设计的, 互相配合使用。
- 除了为 DEWALT 充电式电池充电以外, 这些充电器并非设计用于其他用途。否则, 可能会导致火灾、触电或电击。
- 请勿将充电器暴露于雨中或雪中。
- 断开充电器连接时, 应捏住插头将其拔下, 而非通过拉拽电源线拔下插头。这将降低对插头和电线的损害风险。
- 确保电源线布置在不易踩踏、踢绊、拉扯或会受到损害或压力的位置。
- 除非绝对必要, 否则请勿使用延长线。使用不正确的延长线可能导致火灾、触电或电击的风险。
- 请勿将任何物件放在充电器上面, 或是把充电器放在可能会堵住通风槽的柔软表面, 导致充电器的内部过热。请把充电器放置在远离任何热源的地方。充电器通过外壳顶端和底端的槽进行通风。
- 请勿使用电源线或插头已损坏的充电器, 请立即更换这些充电器。
- 如果充电器受到强烈重击、掉落或出现其他损坏情况, 请勿使用充电器。请将损坏的充电器送到授权服务中心。
- 请勿自行拆卸充电器。请将需要检修或修理的充电器送到授权服务中心。重装不正确可能导致触电、电击或火灾风险。
- 必须立即将已损坏的电源线交由制造商、服务代理或类似的合格人员进行更换以防止安全隐患。
- 清洁前, 请先断开充电器和插座的连接, 以降低触电风险。取出电池包不会降低此风险。
- 不得将两个充电器连接在一起。
- 充电器是为 220-240V 的标准家用电源而设计。请勿试图在任何其他电压下使用充电器。此规则不适用于车载充电器。

为电池充电 (图B)

注意: 为了确保锂离子电池包的效能和使用寿命最大化, 在首次使用电池包之前必须将其完全充电。

1. 插入电池包前, 先将充电器的插头插到相应的电源插座上。













2. 将电池组插入充电器, 确保电池组在充电器中完全就位。红色 (充电中) 指示灯将不断闪烁, 表示充电过程已经开始。
3. 第1阶段充电闪烁指示器表示为大部分电池容量充电的充电过程。第2阶段充电闪烁指示器代表电池包即将充满电。
4. 第1阶段或第2阶段的充电完成后, 对应阶段的指示灯将常亮。第1阶段和第2阶段的充电指示灯常亮时, 表示电池组已充满电, 此时可取出电池组使用, 或将其留在充电器中。

注意: 在拆卸电池包时, 部分充电器需要按住电池包释放按钮

充电器操作

关于电池包的充电状态, 请参阅以下指示灯说明。

指示灯

	第1阶段充电		
	第2阶段充电		
	已完全充电		
	热/冷电池包延迟*		

*红色指示灯会继续闪烁, 但黄色指示灯在本次操作过程中会亮起。电池包达到适当温度后, 黄色指示灯会熄灭, 充电器将恢复充电程序。

兼容充电器不会对故障电池包充电充电器指示灯不亮时表示电池包有故障。

注意: 这可能也表示充电器有问题。

如果充电器提示存在故障, 请将充电器和电池包送到授权的服务中心进行测试。

热/冷电池包延迟

当充电器检测到电池包过热或过冷时, 它会启动热/冷电池包延迟模式, 暂停充电, 直到电池包达到适当的温度。然后, 充电器会自动切换到电池包充电模式。此功能可确保电池包拥有最长的使用寿命。

冷电池包充电速度比热电池包充电速度慢。电池包在整个充电周期的充电速度都会较慢, 即使电池包升温也不会恢复到最大速度。

DCB118 充电器配备了内部风扇, 用于冷却电池包。当电池包需要冷却时, 该风扇会自动启动。如果风扇无法正常工作或通风槽被堵塞, 切勿操作充电器。请勿让异物进入充电器的内部。

电子保护系统

XR 锂离子电池工具采用了电子保护系统设计, 可让电池包免受过载、过热或过度放电之害。

如果电子保护系统处于运作状态, 该工具将自动停止操作。如果发生这种情况, 请将锂离子电池包放在充电器上, 直至其完全充电。

壁挂式安装

这些充电器设计为可以安装在墙上, 也可以直立在桌面或工作台上。如果安装在墙上, 请确保充电器的位置可以连接到电源插座, 并且远离墙角或其他可能妨

碍空气流通的障碍物。将充电器背面作为在墙上安装螺丝的位置模板。使用至少25.4毫米长、螺丝帽直径至少7.9毫米的石膏板螺丝(单独购买)牢牢固定充电器,将螺丝最大限度钉入木材,预留约5.5毫米露在墙外。将充电器背面的安装槽对准露出的螺丝,完全放置到位。

充电器清洁说明

 **警告: 电击危险。**清洁前, 请将充电器从交流电源插座上拔下。可用布或非金属软刷清除充电器外部的污垢和油脂。请勿使用水或任何清洁剂。不得让任何液体渗入工具, 不得让工具的任何部件浸在液体中

电池包

针对所有电池包的重要安全说明

在订购更换电池包时, 请务必附上目录型号和电压。包装箱内的电池包并未完全充电。使用电池包和充电器之前, 请阅读下列安全说明, 然后遵循所述的充电程序。

请阅读所有说明

- 请勿在易爆环境, 如有易燃液体、气体或粉尘的环境中充电或使用电池包。在充电器中插入或取出电池包时可能会点燃粉尘或气体。
- 不得强行将电池包放进充电器。请勿以任何方式改装电池包并将电池包插入不兼容的充电器, 这种操作可能会导致电池包破裂, 造成严重的人身伤害。
- 只使用DEWALT充电器为电池包充电。
- 请勿给电池包喷洒洒水或其他液体或将其浸泡在水或其他液体中。
- 请勿在温度可能降至4°C(39.2°F)的地方(如冬天户外的棚子或金属建筑物中)或达到或超过40°C(104°F)的地方(如夏天户外的棚子或金属建筑物中)存储或使用工具和电池包。
- 即使电池包严重受损或完全损坏, 也请勿焚化电池包。电池包在火中会发生爆炸。锂离子电池包在燃烧时会释放有毒气体和物质。
- 如果电池包液体接触到皮肤, 请立即以中性肥皂和清水冲洗接触的地方。如果电池包液体不慎进入眼睛, 应睁开眼睛并用清水冲洗至少15分钟或直到刺激感消失。如果需要医疗救助, 请告知医护人员。电池包电解质由液状有机碳酸盐和锂盐的混合物组成。
- 已打开电池包的内部物质可能导致呼吸道刺激。请保持空气流通。如果症状持续存在, 请就医。

 **警告: 烧伤危险。**电池包液如果接触到火花或火焰可能会燃烧。

 **警告: 不得以任何理由试图打开电池包。**电池包外壳破裂或损坏时, 请勿将电池包插入充电器。请勿挤压、掉落或损坏电池包。请勿使用受过强烈重击、掉落、碾压或以任何其它方式(如被钉子穿破、受到锤子的重击、踩踏)受损的电池包或充电器。否则可能会引起触电或电击。损坏的电池包应送回服务中心进行回收。

 **警告: 火灾危险。**请勿在存储或搬运电池包时让金属物品接触暴露的电池包两极。例如, 请勿将电池包放在围裙、口袋、工具箱、产品套件盒、抽屉等可能与散钉、螺丝、钥匙等物品接触的地方。

 **小心: 不使用时, 应将工具侧放在稳定的表面上, 以免造成绊倒或坠落的危险。**一些带有大型电池包的工具可以直立在电池包上, 但可能很容易被撞倒。

运输

 **警告: 火灾危险。**电池包运输途中, 如果电池包两极意外接触导电材料, 可能会引发火灾。运输电池时, 务必保护电池两极, 确保与可能接触电池导致短路的材料良好绝缘。**注意: 不应将锂离子电池放入托运行李中。**

DEWALT 电池包符合所有适用的行业和法律标准规定的运输规范, 包括《联合国危险品运输建议规章范本》(UN Recommendations on the Transport of Dangerous Goods)、《国际航空运输协会 (ATA) 危险品规则》(International Air Transport Association (IATA) Dangerous Goods Regulations)、《国际海运危险品 (IMDG) 规则》(International Maritime Dangerous Goods (IMDG) Regulations)和《欧洲危险货物国际公路运输协定》(European Agreement Concerning The International Carriage of Dangerous Goods by Road) (ADR)。离子电池和电池包已遵循《联合国危险品运输建议规章范本手册》第38.3节关于测试和标准的说明通过测试。

大多数情况下, 发运DEWALT 电池包不属于完全管制的9类危险品。通常情况下, 只有当运输包含一个能量等级大于100瓦时 (Wh) 的锂离子电池时, 才需要作为完全管制的9类危险品发运。所有的锂离子电池都在电池包上标明了额定电量。此外, 由于法规比较复杂, 无论瓦时等级是多少, DEWALT 都不建议单独空运锂离子电池。发运包含电池的工作(组合套件)时, 如果电池包的能量等级不大于100瓦时 (Wh), 则可以按计划空运。

无论发运是否纳入完全管制范围内, 运输公司均有责任遵循最新法规中关于包装、标签/标记和单据的要求。本手册本节的信息是出于善意提供, 且认为在编制文档时准确无误。不提供明示或暗示的担保。购买方负有确保其行为遵守适用法规的责任。

运输FLEXVOLT™ 电池

DEWALT FLEXVOLT® 电池包有两种模式: 使用和运输。

使用模式: 当FLEXVOLT™ 电池单独使用或置于DEWALT 18V (20V Max) 产品中时, 将作为18V (20V Max) 电池运行。当FLEXVOLT™ 电池在54V (60V Max) 或108V (120V Max) (两块54V (60V Max) 电池) 产品中时, 其将作为54V (60V Max) 电池运行。

运输方式: 当盖子连接到FLEXVOLT™ 电池时, 电池处于运输模式。盖住盖子以便进行运输。

处于运输模式时, 断开电池包的电源会产生3个瓦特小时额定值 (Wh) 较低的电池包, 和1个瓦特小时额定值较高的电池包。这种增加的3个瓦特小时额定值较低的电池包可使电池包免于遵守某些对高瓦特小时电池包施加的运输规定。

例如, 运输Wh额定值可能表示为3x36 Wh, 即每节36Wh的3节电池包。使用Wh额定值可能表示108Wh (1个电池包)。

使用和运送标签标记示例

 使用: 108Wh
 运输: 3x36Wh

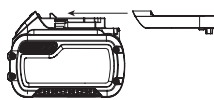

存放建议

1. 最好将电池包存放在阴凉、干燥、远离阳光直射、不会过热或过冷的地方。为了获得最佳的电池包性能和使用寿命，请您在不使用电池包时将其存储在室温下。

2. 长期存储时，建议将已完全充电的电池包从充电器取出，存储在阴凉、干燥的地方，以达到最佳效果。

注意：电池包不应在电池包已完全耗尽的状态下存放。使用电池包之前，必须重新为电池包充电。

充电器和电池包上的标签

除了在本手册中所使用的标志，充电器和电池包的标签还包括：



使用前请阅读使用手册。



有关充电时间，请参阅**技术数据**。



请勿使用导电物体戳刺。



请勿对损坏的电池包充电。



请勿将其暴露于水中。



应立即更换有缺陷的电线。



请只在4°C和40°C之间的温度下充电。



只能在室内使用。



弃置电池包时，请妥善处理以保护我们的环境。



只能用指定的DeWALT充电器给DeWALT电池包充电。使用DeWALT充电器为非DeWALT电池包充电可能会导致电池包爆炸或出现其他危险情况。



请勿焚化电池包。



使用（不含运输盖）示例：Wh额定值表示108Wh（1个108Wh的电池包）。



运输（带内置运输盖）。示例：Wh额定值表示3 x 36Wh（3个36Wh的电池包）。

电池包类型

更多信息，请参考**技术数据**。

包装内的物品

包装中包含：

- 1 砂带机
- 2 80粗细度砂带

1 使用手册

1 侧手柄

注意：电池包、充电器和工具箱没有随N型号附送。电池包和充电器没有随NT型号附送。B型号包括BLUETOOTH® 电池包。

注意：BLUETOOTH®标志和徽标是BLUETOOTH®, SIG, INC.的注册商标，DeWALT对这些标识的任何使用均经过许可。其他商标和商标名均归各自所有者所有。

- 检查工具、部件或附件是否在运输过程中损坏。
- 操作前，请抽空仔细阅读并掌握本手册。

工具上的标记

工具上印有列图形：



使用前请阅读使用手册。



请佩戴听力保护器。



请佩戴护目装备。



请佩戴呼吸保护装置



可见辐射。请勿盯着光看。



热表面。烧伤风险。请勿触摸。



警告

日期代码位置(图A)

生产日期代码 **15** 由4位数的年和2位数的周组成，后跟2位数的工厂代码。

说明(图A)



警告：不得改装本电动工具或其任何部件，否则可能会导致损坏或人身伤害。

- 1 可变速度转盘
- 2 可变速度触发器
- 3 锁定按钮
- 4 主手柄
- 5 侧手柄
- 6 砂带张紧杆
- 7 砂带跟踪螺钉
- 8 直臂
- 9 锁定杆
- 10 防尘罩（需单独购买）
- 11 防尘口
- 12 可旋转LED灯
- 13 电池包
- 14 电池包释放按钮
- 15 日期代码

设计用途

这款砂带机专为砂磨木材、金属、塑料和油漆表面而设计。

为达到最佳平衡效果，请使用5Ah或更小的电池。

请勿在潮湿环境中，或在存在易燃液体或气体的环境中使用本工具。

这款砂带机是专业电动工具。

请勿让儿童接触本工具。

缺乏经验的操作员需要在监督下使用本工具。

- **儿童和体弱者。**在没有他人监督的情况下，儿童或体弱者不适宜使用本产品。
- 本产品不适合体力、感官或智力不足以及缺乏经验、知识或技能的人员（包括儿童）使用，除非一旁有能为他们的安全负责的监督人员。不得在无人监督的情况下让儿童接触本产品。

组装与调整

警告：为降低严重的人身伤害风险，在进行任何调整或取出/安装附件或配件之前，请关闭工具并断开电池包连接。意外启动工具可能会造成伤害。

警告：仅使用DeWALT电池和充电器。

插入或取出工具上的电池包(图B)

注意：确保电池包**13**充满电。

要将电池包安装到工具手柄中

1. 将电池包对准工具手柄内的轨道(图B)。
2. 将电池包滑入手柄内，使其牢牢地固定在工具内，并确保您听到其锁定到位的声音。

从工具中取出电池包

1. 按下电池释放按钮**14**，将电池包从工具握柄中稳妥地拉出。
2. 按本手册充电器部分所述将电池组插入充电器中。

电池包电量计(图B)

一些DeWALT电池包带有一个包含三个绿色LED指示灯的电量计，用于指示电池包内的剩余电量。

按下电量计按钮**16**不松开，即可启动电量计。三个绿色LED指示灯将以组合方式亮起，以指示剩余电量。当电池内的电量低于可用限制时，电量计将不会亮起，电池将需要重新充电。

注意：电量计仅指示电池包的剩余电量。它并不表示该工具的功能，且将根据产品组件、温度和最终使用者的使用情况而有所不同。

安装和拆卸砂磨臂(图C、D)

宽13mm x 457mm (1/2" x 18")的砂带可安装在为相应砂带宽度设计的选配臂上。

工具随附直臂**8**(砂磨宽度13mm);偏置臂**17**(砂磨宽度13mm)作为附件单独出售，详情请咨询当地服务部门。

注意：工具随附已组装好的直臂。

安装

1. 确保砂带张紧杆**6**处于图C所示位置。

2. 松开并取下砂带跟踪螺钉**7**。
3. 检查弹簧**18**是否位于安装孔中。
4. 如图所示定位臂**8**或**17**。
5. 装上砂带跟踪螺钉并拧紧，直到臂与工具对齐。

拆卸

1. 按照**安装和拆卸砂带**部分的说明拆卸砂带**20**(如有)。
2. 松开并取下砂带跟踪螺钉**7**。
3. 拆卸臂**8**或**17**。

警告！小心不要弄掉弹簧。

警告：启动后切勿触摸砂磨臂，因为高温可能会造成伤害。

安装和拆卸砂带(图D, E1-E3)

警告！必须安装弹簧。小心不要弄掉弹簧。

安装

1. 将砂带张紧杆**6**向后拉。
2. 确保砂带**20**内侧的箭头与外壳上的箭头**19**方向一致。
3. 先将砂带放在后砂带轮**22**上。砂带应放在肩部**29**下方(图E1、E2)，然后将另一侧钩住前砂带轮**21**。
4. 将砂带张紧杆移至原来的前方位置。
5. 按照**调整砂带跟踪**一节中的说明调整砂带跟踪。

注意：砂带不应搭在后砂带轮的肩上(图E3)。务必将砂带放在肩部下方。

注意：每次使用后，必须清洁后砂带轮**22**周围的区域，以免灰尘聚集。

拆卸

1. 向后拉砂带张紧杆**6**，释放砂带张力。
2. 将砂带**20**从滑轮上滑下。

调整砂带跟踪(图C、D、F、G)

1. 确保砂带**20**与直臂**8**正确对齐。
2. 打开工具并以低速试运行。
3. 顺时针旋转砂带跟踪螺钉**7**，使砂带向右移动，或逆时针旋转砂带跟踪螺钉，使砂带向左移动，直到砂带沿着直臂的长度笔直运行。

调整臂的倾斜度(图K、L)

如图L所示，直臂**8**或偏置臂**17**可在A(102°)范围内转动并固定在任何需要的角度。调节角度，使工作姿势舒适。

1. 向下翻转锁定杆**9**，松开锁定杆。
2. 将机械臂转到所需位置。
3. 向上翻转锁定杆，牢牢固定臂的位置。

安装侧手柄(图H)

警告：应始终使用该手柄，以完全控制工具。始终确保手柄拧紧。

将侧手柄**5**拧紧到锉刀头主体的螺纹安装孔中**23**。



安装防尘罩(图H)

本工具随DCM2000DC防尘罩提供(单独出售)。该附件与工具的锉刀头主体相连。

要安装防尘罩 **10**，首先要断开工具的电池连接。

1. 将防尘罩 **10** 的肋条 **24** 沿着锉刀头主体 **23** 的凹槽放置。
2. 将防尘罩 **10** 对准锉刀体，使防尘罩孔与锉刀体孔对齐。
3. 使用侧手柄 **5** 将防尘罩拧紧到锉刀头上。

将除尘器安装到防尘罩上 (图P、Q)

-  **警告:** 砂磨或抛光金属时，请勿安装防尘罩和连接除尘器。
-  **警告:** 有吸入粉尘的危险。为降低人身伤害风险，请务必佩戴经认可的防尘口罩。
-  **警告:** 砂磨表面涂层（聚氨酯、亚麻籽油等）时产生的砂磨粉尘可能在除尘器或其他地方自燃并引起火灾。为降低风险，请严格遵守砂光机手册和涂层生产商的说明。

DCM200DC 防尘罩与 DWH161 DeWALT 通用除尘器（需单独购买）兼容。



- 将集尘口 **11** 摩擦安装到 DWH161 通用除尘器的软管 **25** 上。

DWV9170 适配器 **30**（如有）可用于将工具连接到 DeWALT AirLock™ 连接系统（需单独购买）。



1. 将 AirLock™ 连接器 **31** 推到 DWV9170 适配器上。
2. 将 DWV9170 适配器摩擦安装到防尘罩上。

操作

使用说明

-  **警告:** 务必遵守安全指示和适用法规。
-  **警告:** 为降低严重的人身伤害风险，在进行任何调整或取出/安装附件或配件之前，请关闭工具并断开电池包连接。意外启动工具可能会造成伤害。
-  **警告:** 使用过程中切勿接触锉刀体，因为高温可能会造成伤害。

正确的双手放置位 (图J)

-  **警告:** 为了减低严重人身伤害的风险，请务必如图示那样正确放置双手。
-  **警告:** 为了减低造成严重人身伤害的风险，预期有突然反作用力时务必握紧。

手部的正确位置应该是一只手放在主手柄 **4** 上，一只手放在侧手柄 **5** 上。

LED 工作灯 (图A、N)

-  **小心:** 请不要直视 LED 工作灯。直视可能会导致视力严重受损。

可旋转 LED 工作灯 **12** 可在 60° 内进行三级调节。按下变速触发开关 **2** 启动工具时，可旋转 LED 工作灯会自动打开。松开可变速度触发器 20 秒后，可旋转 LED 工作灯将关闭。

注意: 小心不要划伤工作灯的镜头，否则可能会失去照明。使用干布擦拭工作灯镜头上的污垢。

可变速度转盘 (图O)

利用可变速度转盘 **1** 可以根据工件材料调整工具速度。工具速度可在 1 到 7 之间调节。使用细磨粒、加工塑料或陶瓷以及去除油漆或清漆表面时，请使用低速设置。使用粗磨粒和去除大量材料时，请使用高速设置。

- 将可变速度转盘 **1** 调到所需的档位。

启动和关闭 (图A)



-  **小心:** 未解锁工具之前，切勿用力扣动可变速度触发器。请参阅**锁定按钮**部分。这会导致可变速度触发器断裂。
1. 要启动工具，拉动可变速度触发器 **2**。
 2. 要关闭工具，松开可变速度触发器。

锁定按钮 (图I)

-  **警告:** 为防止意外启动，该工具配有锁定按钮。

1. 要锁定工具，请将锁定按钮 **3** 按到锁定位置。当锁定按钮处于锁定位置时，工具被锁定，不能扣动可变速度触发器 **2**。
 2. 要解锁工具，请将锁定按钮 **3** 按到解锁位置。
- 注意:** 当机械臂旋转到存储位置（超过 102°）时，工具被锁定，且无法扣动可变速度触发器。

特殊应用 (图A、R-V)

-  **警告:** 为减少火灾或严重伤害的危险，避免砂磨铝和镁等易燃材料。
-  **警告!** 操作时，切勿让旁观者站在工具前面，以免砂带断裂或从臂上脱落。

直臂 (图R-U)

直臂 **8** 用于一般用途、砂磨、去毛刺和开槽。工作应始终在前滑轮 **21**（图R）的范围 (A) 内或压盘 **32** 的范围 (B) 内进行，如直臂 (图R) 所示。

- 在狭窄区域砂磨时，请参考直臂的 C 区域 (图S)。
- 一般砂磨请参考直臂的 D 区和 E 区 (图T、U)。

偏置臂 (图V)

使用位置

- 使用偏置臂 **17** 砂磨曲面。
- 砂磨曲面时，请参考偏置臂的 F 区 (图V)。

最佳使用提示

- 始终用双手握住工具。
- 不要对工具施加太大的压力。
- 为了延长砂带的使用寿命，只用砂带的底面进行砂磨。
- 操作臂时，不要用力过猛。
- 定期检查砂带的状况 **20**。必要时更换。
- 始终顺着木材的纹理砂磨。
- 砂磨新的油漆层之前，应使用超细磨粒。
- 有关可用附件的详细信息，请咨询零售商。

维护

您的电动工具设计精良，可以长期使用，仅需极少维护。若要持续令人满意的工作效果，则需对工具进行适当的保养和定期清洁。

警告：为降低严重的人身伤害风险，在进行任何调整或取出/安装附件或配件之前，请关闭工具并断开电池包连接。意外启动工具可能会造成伤害。

充电器和电池包无法维修。

Tool Connect™芯片 (图W)

警告：为降低严重人身伤害的风险，请先关闭工具并拆除电池组，然后再进行任何调节或拆除/安装配件或附件。意外启动工具可能会造成伤害。

您的工具留有Tool Connect™芯片安装槽支持安装Tool Connect™芯片 (Tool Connect™芯片需单独购买)。

在您的智能设备 (例如智能手机或平板电脑) 中，Tool Connect™芯片是可选应用，能够连接设备，使用移动应用，实现库存管理的功能。

请参见**Tool Connect™芯片说明书**，获取更多信息。

安装Tool Connect™芯片

1. 拆除用于将Tool Connect™芯片保护盖**27**安装到工具上的固定螺钉**26**。
2. 拆除保护盖，将Tool Connect™芯片插入空槽**28**中。
3. 请确保Tool Connect™芯片与外壳齐平。用固定螺钉来固定保护盖，并拧紧螺钉。
4. 请参见**Tool Connect™芯片说明书**，获取更多指导。

存储 (图K-M)

小心：移动直臂时小心不要夹到手指。否则可能会造成人身伤害。

如图M所示，直臂**8**可以折叠起来以节省存储空间。直臂的移动角度可达172°。

1. 向下翻转锁定杆**9**，松开锁定杆。将臂旋转102°。
2. 按下锁定按钮**3**，然后在图L所示的范围B (102°至172°) 内调节直臂角度。
3. 向上翻转锁定杆，固定直臂。

注意：当机械臂旋转到存储位置 (超过102°) 时，工具被锁定，且无法扣动可变速度触发器。

润滑

本电动工具无需另行润滑。

清洁

警告：电击和机械危险。清洁前，请将电器与电源断开。

警告：为确保操作安全、有效，请注意清洁电器和通风槽。

警告：不得使用溶剂或其它刺激性化学制品来清洁工具的非金属部件。这些化学物质可能会削弱这些部位使用的材料。请用布蘸温和的肥皂水擦拭。不得让任何液体渗入工具，不得让工具的任何部件浸在液体中。

通风槽可以用干燥、柔软的非金属刷和/或合适的除尘器进行清洁。请勿使用水或任何清洁剂。请戴上合格的护目镜和防尘面具。

可选配件

警告：由于除DeWALT提供的配件外，其他配件没有经过本产品的测试，因此将这些配件与本工具一起使用可能会有危险。为了减少受伤的风险，本产品仅可使用DeWALT推荐的配件。

请向您的经销商咨询更多关于合适附件的信息。

保护环境

 分类回收。由此符号标记的产品和电池包不得与普通家庭垃圾一起处理。

 产品和电池包包含可恢复或回收的材料，从而降低对原材料的需求。请根据当地规定回收电子产品和电池包。要获得更多信息，请参看www.2helpU.com。

充电式电池包

本电池包使用寿命长，不能提供顺利完成工作所需的电力时，必须进行充电。电池包技术寿命结束时，请妥善处理以保护环境：

- 耗尽电池包的电力，然后将其从工具上拆下。
- 锂离子电池是可回收的。请将它们送往您的经销商处或当地的回收站。回收的电池包将被妥善循环使用或处理。

售后服务和维修

DeWALT服务中心配备了训练有素的人员，能为客户提供高效、可靠的产品服务。如果您在未经授权的服务中心进行维修，我们不承担任何责任。您可以参见产品包装中的“联系中心定位器”宣传单页，通过热线电话、网站或社交媒体联系我们，找到距离您最近的DeWALT服务中心。

制造商： 百得德国公司

地址： Black & Decker Str. 40 65510 Idstein, 德国

产地： 江苏苏州

