

INSTRUCTION MANUAL

DEWALT®

D28492, D28493
Heavy-Duty Angle Grinder

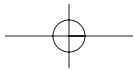

English

1

Simplified Chinese

10

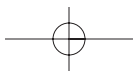
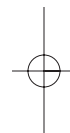
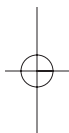

SAVE THESE INSTRUCTIONS

▲ WARNING! Read and understand all instructions. Failure to follow all instructions listed below, may result in electric shock, fire and/or serious personal injury.

Technical data

		D28492	D28493
Voltage	Volt	220V	220V
Power input	W	2200W	2200W
No-Load speed	min ⁻¹	6500	8500
Wheel diameter	mm	230	180
Spindle		M14	M14
Net weight	kg	4.6	4.6

General Safety Instructions

WORK AREA

- **Keep your work area clean and well lit.** Cluttered benches and dark areas invite accidents.
- **Do not operate power tools in explosive atmospheres, such as in the presence of flammable liquids, gases, or dust.** Power tools create sparks which may ignite the dust or fumes.
- **Keep bystanders, children, and visitors away while operating a power tool.** Distractions can cause you to lose control.

ELECTRICAL SAFETY

- **Grounded tools must be plugged into an outlet properly installed and grounded in accordance with all codes and ordinances.** Never remove the grounding prong or modify

the plug in any way. Do not use any adapter plugs. Check with a qualified electrician if you are in doubt as to whether the outlet is properly grounded. If the tools should electrically malfunction or break down, grounding provides a low resistance path to carry electricity away from the user. **Applicable only to Class I (grounded) tools.**

- **Double insulated tools are equipped with a polarized plug (one blade is wider than the other.) This plug will fit in a polarized outlet only one way. If the plug does not fit fully in the outlet, reverse the plug. If it still does not fit, contact a qualified electrician to install a polarized outlet. Do not change the plug in any way.** Double insulation eliminates the need for the three wire grounded power cord and grounded power supply system. **Applicable only to Class II (double insulated) tools.**
- **Avoid body contact with grounded surfaces such as pipes, radiators, ranges and refrigerators.** There is an increased risk of electric shock if your body is grounded.
- **Don't expose power tools to rain or wet conditions.** Water entering a power tool will increase the risk of electric shock.
- **Do not abuse the cord. Never use the cord to carry the tools or pull the plug from an outlet.** Keep cord away from heat, oil, sharp edges or moving parts. Replace damaged cords immediately. Damaged cords increase the risk of electric shock.

PERSONAL SAFETY

- **Stay alert, watch what you are doing and use common sense when operating a power tool. Do not use tool while tired or under the influence of drugs, alcohol, or medication.** A moment of inattention while operating power tools may result in serious personal injury.

- **Dress properly. Do not wear loose clothing or jewelry. Contain long hair. Keep your hair, clothing, and gloves away from moving parts.** Loose clothes, jewelry, or long hair can be caught in moving parts. Air vents often cover moving parts and should also be avoided.
- **Avoid accidental starting. Be sure switch is off before plugging in.** Carrying tools with your finger on the switch or plugging in tools that have the switch on invites accidents.
- **Remove adjusting keys or wrenches before turning the tool on.** A wrench or a key that is left attached to a rotating part of the tool may result in personal injury.
- **Do not overreach. Keep proper footing and balance at all times.** Proper footing and balance enables better control of the tool in unexpected situations.
- **Use safety equipment. Always wear eye protection. Dust mask, non-skid safety shoes, hard hat, or hearing protection must be used for appropriate conditions.**

TOOL USE AND CARE

- **Use clamps or other practical way to secure and support the workpiece to a stable platform.** Holding the work by hand or against your body is unstable and may lead to loss of control.
- **Do not force tool. Use the correct tool for your application.** The correct tool will do the job better and safer at the rate for which it is designed.
- **Do not use tool if switch does not turn it on or off.** Any tool that cannot be controlled with the switch is dangerous and must be repaired.
- **Disconnect the plug from the power source before making any adjustments, changing accessories, or storing the tool.** Such preventative safety measures reduce the risk of starting the tool accidentally.

- **Store idle tools out of reach of children and other untrained persons.** Tools are dangerous in the hands of untrained users.
- **Maintain tools with care. Keep cutting tools sharp and clean.** Properly maintained tools, with sharp cutting edges are less likely to bind and are easier to control.
- **Check for misalignment or binding of moving parts, breakage of parts, and any other condition that may affect the tools operation.** If damaged, have the tool serviced before using. Many accidents are caused by poorly maintained tools.
- **Use only accessories that are recommended by the manufacturer for your model.** Accessories that may be suitable for one tool may become hazardous when used on another tool.

SERVICE

- **Tool service must be performed only by qualified repair personnel.** Service or maintenance performed by unqualified personnel could result in a risk of injury.
- **When servicing a tool, use only identical replacement parts.** Follow instructions in the Maintenance section of this manual. Use of unauthorized parts or failure to follow Maintenance instructions may create a risk of electric shock or injury.

Additional Specific Safety Instructions for Grinders

- **Always use proper guard with grinding wheel.** A guard protects operator from broken wheel fragments and wheel contact.
- **Accessories must be rated for at least the speed recommended on the tool warning label.** Wheels and other accessories running over rated speed can fly apart and cause injury. Refer to the table below. Accessory ratings are above rated no-load tool speeds because actual tool speeds may vary.

NOTE: The rated no load tool speed is printed on the name plate and embossed on the gear case.

- **Hold tool by insulated gripping surfaces when performing an operation where the cutting tool may contact hidden wiring or its own cord.** Contact with a “live” wire will make exposed metal parts of the tool “live” and shock the operator.
- **Before using, inspect recommended accessory for cracks or flaws.** If such a crack or flaw is evident, discard the accessory. The accessory should also be inspected whenever you think the tool may have been dropped.
- **When starting the tool with a new or replacement wheel, or a new or replacement wire brush installed, hold the tool in a well protected area and let it run for one minute.** If the wheel has an undetected crack or flaw, it should burst in less than one minute. If the wire brush has loose wires, they will be detected. Never start the tool with a person in line with the wheel. This includes the operator.
- **In operation, avoid bouncing the wheel or giving it rough treatment.** If this occurs, stop the tool and inspect the wheel.
- **Direct sparks away from operator, bystanders or flammable materials.** Sparks may be produced while using a sander or grinder. Sparks may cause burns or start fires.
- **Always use side handle. Tighten the handle securely.** The side handle should always be used to maintain control of the tool at all times.

⚠ CAUTION: Use extra care when grinding into a corner because a sudden, sharp movement of the grinder may be experienced when the wheel contacts a secondary surface.

- **Clean out your tool often, especially after heavy use.** Dust and grit containing metal particles often accumulate on interior surfaces and could create an electric shock hazard.

⚠ CAUTION: Wear appropriate personal hearing protection during use. Under some conditions and duration of use, noise from this product may contribute to hearing loss.

⚠ WARNING: Some dust created by power sanding, sawing, grinding, drilling, and other construction activities contains chemicals known to cause cancer, birth defects, or other reproductive harm. Some examples of these chemicals are:

- lead from lead-based paints,
- crystalline silica from bricks and cement and other masonry products, and
- arsenic and chromium from chemically-treated lumber (CCA).

Your risk from these exposures varies, depending on how often you do this type of work. To reduce your exposure to these chemicals: work in a well ventilated area, and work with approved safety equipment, such as those dust masks that are specially designed to filter out microscopic particles.

- **Avoid prolonged contact with dust from power sanding, sawing, grinding, drilling, and other construction activities. Wear protective clothing and wash exposed areas with soap and water.** Allowing dust to get into your mouth, eyes, or lay on the skin may promote absorption of harmful chemicals.
- The label on your tool may include the following symbols.

V.....volts	A.....amperes
Hz.....hertz	Wwatts
minminutes	~alternating current
===direct current	n ₀no load speed
□Class II Construction	.../min.....revolutions or
⊕earthing terminal	reciprocation per
⚠safety alert symbol	minute

FAMILIARIZATION

Large Angle Grinders and Large Angle Sanders are designed for heavy material removal in extended use applications. The following grinders and sanders are described in this manual.

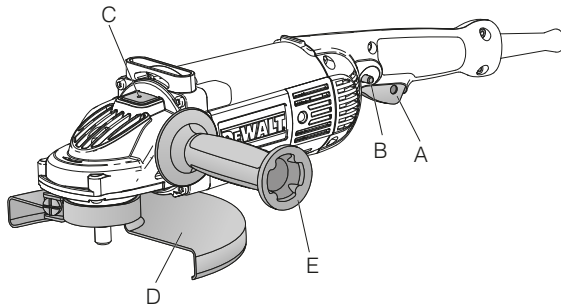

Components

- A. Trigger Switch
- B. Lock On Button
- C. Spindle Lock
- D. Guard
- E. Side Handle

Features

SWITCH

The tool is controlled by a trigger switch (A). A lock-on button (B) provides increased comfort in extended use applications.

MULTIPLE SIDE HANDLE POSITIONS

The side handle can be properly positioned in two locations based on personal preference and application. The side handle must be used at all times to maintain proper control of the tool.

SPINDLE LOCK

The spindle lock pin is provided to prevent the spindle from rotating when installing or removing wheels. Operate the spindle lock pin only when the tool is turned off and unplugged from the power source. To engage the lock, depress the spindle lock button (C) and rotate the spindle until you are unable to rotate it further.

NOTE: Never depress the spindle lock button while the grinder is running. Never turn on the grinder while the spindle lock button is depressed. Damage to your tool may result.

MOUNT

The grinder is equipped with a mount, enabling easy wheel installation and removal.

Accessories and Attachments

It is important to choose the correct guards, backing pads and flanges to use with grinder accessories. See the chart on pages 5 for information on choosing the correct accessories.

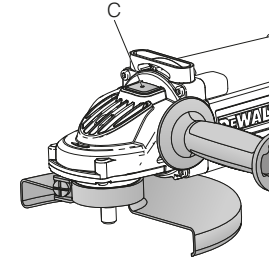

⚠CAUTION: Accessories must be rated for at least the speed recommended on the tool warning label. Wheels and other accessories running over rated speed can fly apart and cause injury.

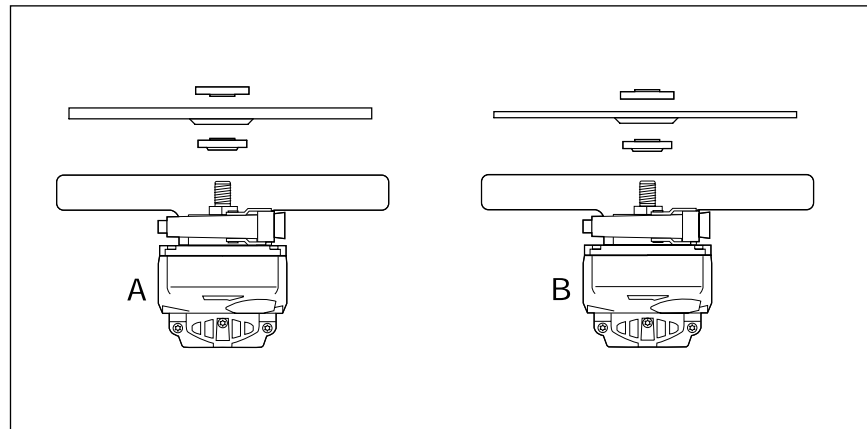

NOTE: Wheel size must match guard size; i.e., a new 180mm wheel may not be used with a 230mm guard. The bottom surface of wheel must be inside the bend of the guard lip.

ASSEMBLY AND ADJUSTMENTS

Attaching the Side Handle

To install the side handle, thread the handle into one of the two positions and tighten **securely** by turning clockwise.

OPERATION

Power Source

Plug the large angle grinder into a dedicated electrical circuit. Operating this tool on a circuit with other tools will decrease tool performance.

Switch

CAUTION: Before connecting the tool to a power source or after a power failure, depress and release the trigger switch (A) once without depressing the lock-on button (B) to ensure that the switch is in the off position. If the trigger switch is locked on, the tool will start unexpectedly when power is reconnected to the tool. Hold the side handle and rear handle firmly to maintain control of tool at start up and during use.

TRIGGER OPERATION

To turn the tool on, depress the trigger switch (A). The tool will remain running while the trigger is depressed. Turn the tool off by releasing the trigger.

TRIGGER OPERATION WITH LOCK-ON FEATURE

To turn tool on, depress trigger. Depress and hold lock-on button (B) while releasing trigger. Lock-on button will remain depressed and tool will remain on.

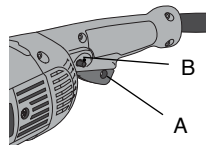
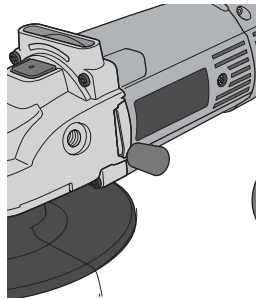

To turn the tool off, depress and release trigger. The lock pin button will pop out, permitting the trigger to disengage and causing the tool to turn off.

NOTE: Allow the tool to reach full speed before touching tool to work surface. Lift the tool from the work surface before turning the tool off.

CAUTION: Make sure the wheel has come to a complete stop before setting the tool down.

REMOVAL OF LOCK-ON FEATURE

The lock-on button can be permanently removed without compromising compliance with regulatory agencies shown on the tool's nameplate. Removal of the lock pin must be done by a DEWALT service center.

Mounting and Using Depressed Center Grinding Wheels and Sanding Flap Discs

MOUNTING AND REMOVING GUARD

Turn off and unplug tool before making any adjustments or removing or installing accessories. Before reconnecting the tool, depress and release the trigger switch to ensure that the tool is off.

IMPORTANT INFORMATION ABOUT GUARDS

Guards must be used with all grinding wheels, sanding flap discs, wire brushes and wire wheels. The tool may be used without a guard only when sanding with conventional sanding discs.

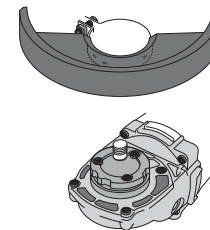

▲ CAUTION: When using a grinding wheel with a guard, be sure that the bottom surface of the grinding wheel is inside the guard lip.

MOUNTING NON-HUBBED WHEELS

Depressed center, grinding wheels must be used with available accessory flanges. See the charts on pages 5 of this manual for more information.

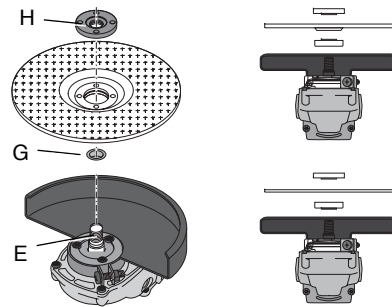

1. Install the metal backing flange (G) on spindle (E) against the mount.
2. Place wheel against the backing flange, centering the wheel on the backing flange pilot.
3. While depressing the spindle lock button, thread the clamp nut (H) on spindle, piloting the raised hub on clamp nut in the center of grinding wheel.
4. Tighten the clamp nut with a wrench.
5. Reverse the above procedure to remove the wheel.

SURFACE GRINDING WITH GRINDING WHEELS

1. Allow the tool to reach full speed before touching tool to work surface.
2. Apply minimum pressure to work surface, to allow the tool to operate at high speed.
3. Maintain a 20° to 30° angle between the tool and work surface.
4. Continuously move the tool in a forward and back motion to avoid creating gouges in the work surface.
5. Remove the tool from work surface before turning tool off. Allow the tool to stop rotating before setting it down.

EDGE GRINDING WITH GRINDING WHEELS

▲ CAUTION: Wheels used for cutting and edge grinding may break if they bend or twist while the tool is being used to do cut-off work or deep grinding. To reduce the risk of serious injury, limit the use of these wheels with a standard guard to shallow cutting and notching (less than 1/2" in depth). The open side of the guard must be positioned away from the operator. For deeper cutting with a wheel, use a closed, guard. Guards are available at extra cost from your local dealer or authorized service center.

1. Allow the tool to reach full speed before touching the tool to the work surface.
2. Apply minimum pressure to work surface, to allow the tool to operate at high speed.
3. Protect yourself during edge finishing by directing the open side of the guard away from you.
4. Move the tool continuously in a forward and back motion to avoid creating gouges in the work surface.
5. Remove tool from work surface before turning the tool off. Allow the tool to stop rotating before setting it down.

▲ WARNING: Do not use edge grinding wheels for surface grinding applications because edge grinding wheels are not designed for side pressures encountered with surface grinding. Wheel breakage and injury may result.

SURFACE FINISHING WITH SANDING FLAP DISCS

1. Allow the tool to reach full speed before touching tool to work surface.
2. Apply minimum pressure to work surface, to allow the tool to operate at high speed.
3. Maintain a 5° to 10° angle between the tool and work surface.
4. Continuously move the tool in a forward and back motion to avoid creating gouges in the work surface.
5. Remove the tool from work surface before turning tool off. Allow the tool to stop rotating before setting it down.

Mounting and Using Cutting Wheels

Cutting wheels include diamond wheels and abrasive discs. Abrasive cutting wheels for metal and concrete use are available. Diamond blades for concrete cutting can also be used.

▲ WARNING: A closed, cutting wheel guard is not included with this tool. Cutting wheels require proper flanges and guards. A 180mm cutting guard, is available as an accessory and includes proper, matching flanges. Failure to use proper flange and guard can result in injury resulting from wheel breakage and wheel contact.

MOUNTING CLOSED GUARD

Turn off and unplug tool before making any adjustments or removing or installing accessories. Before reconnecting the tool, depress and release the trigger switch to ensure that the tool is off.

1. Align the lugs with slots on the gear case cover. Position the guard facing backward, as shown.
2. Push the guard down until the guard lug engages and rotates freely in the groove on the gear case hub.
3. Rotate guard into desired working position. The guard body should be positioned between the spindle and the operator to provide maximum operator protection.
4. Secure the guard on the gear case cover. You should be unable to rotate the guard by hand when the latch is in closed position. Do not operate grinder with a loose guard or clamp lever in open position.

NOTE: The guard is pre-adjusted to the diameter of the gear case hub at the factory. If, after a period of time, the guard becomes loose, tighten the adjusting screw.

MOUNTING CUTTING WHEELS

1. Remove mount.
2. Install wheel backing flange, aligning flats on spindle with flats on backing flange.
3. Place the wheel on the backing flange, centering the wheel on the backing flange pilot.
4. Install the clamp nut, ensuring that the wheel remains centered on the backing flange.
5. Depress the spindle lock button and tighten clamp nut with wrench.
6. Reverse the above procedure to remove the wheel.

USING CUTTING WHEELS

1. Allow tool to reach full speed before touching tool to work surface.
2. Apply minimum pressure to work surface, allowing tool to operate at high speed.
3. Once you begin a cut, maintain the angle of the cutting wheel

to the work surface. This will keep you from bending the wheel which could result in wheel breakage and injury.

4. Remove the tool from work surface before turning tool off. Allow the tool to stop rotating before setting it down.

MAINTENANCE

Cleaning

Blowing dust and grit out of the motor housing using clean, dry compressed air is a necessary regular maintenance procedure. Dust and grit containing metal particles often accumulate on interior surfaces and could create an electrical shock hazard if not frequently cleaned out. **ALWAYS WEAR SAFETY GLASSES.**

▲ CAUTION: *Never use solvents or other harsh chemicals for cleaning the non-metallic parts of the tool. Use a clean, dry rag only.*

Lubrication

DEWALT tools are properly lubricated at the factory and are ready for use.

Repairs

To assure product SAFETY and RELIABILITY, repairs, maintenance and adjustment should be performed by authorized service centers or other qualified service personnel. Always use identical replacement parts.

Motor Brushes

When brushes become worn, the tool will automatically stop, preventing damage to the motor. Brush replacement should be performed by DEWALT authorized service centers or other qualified service personnel. Qualified service personnel should follow the procedures below when replacing motor brushes.

Turn off and unplug tool before making any adjustments or removing or installing accessories. Before reconnecting the tool, depress and release the trigger switch to ensure that the tool is off.

1. Remove the brush doors located on the sides of motor housing.
2. To remove the brush, hold the female terminal, which is attached to the brush lead wire, and disconnect the female terminal from the male terminal.
3. Pull the brush straight up out of the brush holder.
4. Replace brushes, in pairs, with original DEWALT brushes available from DEWALT authorized service centers.
5. Ensure that the brushes slide freely in brush box.
6. Reconnect the brush lead wire to brush box terminal.
7. Re-install the brush doors before using the tool. Torque screws to 10 in-lbs, maximum. Overtightening may cause screws to strip.

Purchasing Accessories

Recommended accessories for use with your tool are available at extra cost from you local dealer or authorized service center.

▲ CAUTION: *The use of any other accessory not recommended for use with this tool could be hazardous.*

角向磨光机 D28492型 / D28493型

欢迎购买得伟(DeWALT)产品!

感谢您选择得伟产品。凭借多年的经验和产品开发及创新方面的不断努力，得伟已经成功跻身于专业电动工具用户的最可靠伙伴之一。

技术参数

		D28492	D28493
电压	伏特	220V	220V
额定功率	瓦	2200W	2200W
额定转速	分钟	6500	8500
砂轮直径	毫米	230	180
	主轴	M14	M14
	净重	4.6	4.6

电动工具通用安全警告



警告！ 阅读所有警告和所有说明。不遵照以下警告和说明会导致电击、着火和/或严重伤害。

保存所有警告和说明书以备查阅

在所有下列警告中术语“电动工具”指市电驱动（有线）电动工具或电池驱动（无线）电动工具。

a) 工作场地的安全

- 1) 保持工作场地清洁和明亮。混乱和黑暗的场地会引发事故。
- 2) 不要在易爆环境，如有易燃液体、气体或粉尘的环境下操作电动工具。电动工具产生的火花会点燃粉尘或气体。
- 3) 让儿童和旁观者离开后操作电动工具。注意力不集中会使操作者失去对工具的控制。

b) 电气安全

- 1) 电动工具插头必须与插座相配。绝不能以任何方式改装插头。需接地的电动工具不能使用任何转换插头。未经改装的插头和相配的插座将减少电击危险。
- 2) 避免人体接触接地表面，如管道、散热片和冰箱。如果你身体接地会增加电击危险。
- 3) 不得将电动工具暴露在雨中或潮湿环境中。水进入电动工具将增加电击危险。
- 4) 不得滥用电线。绝不能使用电线搬运、拉动电动工具或拔出其插头。使电线远离热源、油、锐边或运动部件。受损或缠绕的软线会增加电击危险。
- 5) 当在户外操作电动工具时，使用适合户外使用的外接软线。适合户外使用的软线将减少电击危险。
- 6) 如果在潮湿的环境下操作电动工具是不可避免的，应使用剩余电流动作保护器 (RCD)。使用 RCD 可减小电击的危险。

c) 人身安全

- 1) 保持警觉，当操作电动工具时关注所从事的操作并保持清醒。当你感到疲倦，或在有药物、酒精或治疗反应时，不要操作电动工具。在操作电动工具时瞬间的疏忽会导致严重人身伤害。
- 2) 使用个人防护装置。始终佩戴护目镜。安全装置，诸如适当条件下使用防尘面具、防滑安全鞋、安全帽、听力防护等装置能减少人身伤害。
- 3) 防止意外起动。确保开关在连接电源和/或电池盒、拿起或搬运工具时处于关断位置。手指放在已经接通电源的开关上或开关处于接通时插入插头可能会导致危险。
- 4) 在电动工具接通之前，拿掉所有调节钥匙或扳手。遗留在电动工具旋转零件上的扳手或钥匙会导致人身伤害。
- 5) 手不要伸得太长。时刻注意立足点和身体平衡。这样在意外情况下能很好地控制电动工具。
- 6) 着装适当。不要穿宽松的衣服或佩戴饰品。让衣服、手套和头发远离运动部件。宽松衣服、配饰或长发可能会卷入运动部件中。

7) 如果提供了与排屑、集尘设备连接用的装置,要确保这些装置连接完好且使用得当。使用这些装置可减少尘屑引起的危险。

d) 电动工具的使用和注意事项

- 1) 不要滥用电动工具,根据用途使用适当的电动工具。选用适当设计的电动工具会使你工作更有效、更安全。
- 2) 如果开关不能接通或关断工具电源,则不能使用该电动工具。不能用开关来控制的电动工具是危险的且必须进行修理。
- 3) 在进行任何调节、更换附件或贮存电动工具之前,必须从电源上拔掉插头和/或使电池盒与工具脱开。这种防护性措施将减少工具意外起动的危险。
- 4) 将闲置不用的电动工具贮存在儿童所及范围之外,并且不要让不熟悉电动工具或对这些说明不了解的人操作电动工具。电动工具在未经培训的用户手中是危险的。
- 5) 保养电动工具。检查运动部件是否调整到位或卡住、检查零件破损情况和影响电动工具运行的其他状况。如有损坏,电动工具应在使用前修理好。许多事故由维护不良的电动工具所引发。
- 6) 保持切削刀具锋利和清洁。保养良好的有锋利切削刃的刀具不易卡住而且容易控制。
- 7) 按照使用说明书,考虑作业条件和进行的作业来使用电动工具、附件和工具的刀头等。将电动工具用于那些与其用途不符的操作可能会导致危险。

e) 维修

- 1) 将你的电动工具送交专业维修人员,使用同样的备件进行修理。这样将确保所维修的电动工具的安全性。

所有操作的使用说明书

砂磨、砂光、钢丝砂光或砂磨切割操作的通用安全警告:

- a) 该电动工具是用于实现砂轮机、砂光机、钢丝刷或切断工具功能的。阅读随该电动工具提供的所有安全警告、说明、图解和规定。不了解以下所列所有说明将导致电击、着火和/或严重伤害。
- b) 不推荐用该电动工具进行诸如抛光等操作。电动工具不按指定的功能去操作,可能会发生危险和引起人身伤害。
- c) 不使用非工具制造商推荐和专门设计的附件。否则该附件可能被装到你的电动工具上,而它不能保证安全操作。
- d) 附件的额定速度必须至少等于电动工具上标出的最大速度。附件以比其额定速度大的速度运转会发生爆裂和飞溅。
- e) 附件的外径和厚度必须在电动工具额定能力范围之内。不正确的附件尺寸不能得到充分防护或控制。
- f) 砂轮、法兰盘、靠背垫或任何其他附件的轴孔尺寸必须适合于安装到电动工具的主轴上。带轴孔的、与电动工具安装件不配的附件将会失稳、过度振动并会引起失控。
- g) 不要使用损坏的附件。在每次使用前要检查附件,例如砂轮是否有碎片和裂缝,靠背垫是否有的裂缝、撕裂或过度磨损,钢丝刷是否松动或金属丝是否断裂。如果电动工具或附件跌落了,检查是否有损坏或安装没有损坏的附件。检查和安装附件后,让自己和旁观者的位置远离旋转附件的平面,并以电动工具最大空载速度运行1min。损坏的附件通常在该试验时会碎裂。
- h) 戴上防护用品。根据适用情况,使用面罩、安全护目镜或安全眼镜。适用时,戴上防尘面具、听力保护器、手套和能挡小磨料或工件碎片的工作围裙。眼防护罩必须挡住各种操作产生的飞屑。防尘面具或口罩必须能过滤操作产生的颗粒。长期暴露在高强度噪声中会引起失聪。
- i) 让旁观者与工作区域保持一安全距离。任何进入工作区域的人

必须戴上防护用品。工件或破损附件的碎片可能会飞出并引起紧靠着操作区域的旁观者的伤害。切割附件触及带电导线会使电动工具外露的金属零件带电，并使操作者触电。

j) 当在切割附件有可能切割到暗线或自身电线的场所进行操作时，只能通过绝缘握持面来握住电动工具。切割附件碰到一根带电导线可能会使电动工具的外露金属零件带电并使操作者发生电击危险。

k) 使软线远离旋转的附件。如果控制不当，软线可能被切断或缠绕，并使得你的手或手臂可能被卷入旋转附件中。

l) 直到附件完全停止运动才放下电动工具。旋转的附件可能会抓住表面并拉动电动工具而让你失去对工具的控制。

m) 当携带电动工具时不要开动它。意外地触及旋转附件可能会缠绕你的衣服而使附件伤害身体。

n) 经常清理电动工具的通风口。电动机风扇会将灰尘吸进机壳，过多的金属粉末沉积会导致电气危险。

o) 不要在易燃材料附件操作电动工具。火星可能会点燃这些材料。

p) 不要使用需用冷却液的附件。用水或其他冷却液可能会导致电腐蚀或电击。

对所有操作的进一步安全说明

反弹和相关警告

反弹是因卡住或缠绕住的旋转砂轮、靠背垫、钢丝刷或其他附件而产生的突然反作用力。卡住或缠绕会引起旋转附件的迅速堵转，随之使失控的电动工具在卡住点产生与附件旋转方向相反的运动。

例如，如果砂轮被工件缠绕或卡住，伸入卡住点的砂轮边缘可能会进入材料表面而引起砂轮爬出或反弹。砂轮可能飞向或飞离操作者，这取决于砂轮在卡住点的运动方向。在此条件下砂轮也可

能碎裂。

反弹是电动工具误用和/或不正确操作工序或条件的结果，可以通过采取以下给出的适当预防措施得以避免。

a) 保持紧握电动工具，使你的身体和手臂处于正确状态以抵抗反弹力。如有辅助手柄，则要一直使用，以便最大限度控制住启动时的反弹力或反力矩。如采取合适的预防措施，操作者就可以控制反力矩或反弹力。

b) 绝不能将手靠近旋转附件。附件可能会反弹碰到手。

c) 不要站在发生反弹时电动工具可能移动到的地方。反弹将在缠绕点驱使工具逆砂轮运动方向运动。

d) 当在尖角、锐边等处作业时要特别小心。避免附件的弹跳和缠绕。尖角、锐边和弹跳具有缠绕旋转附件的趋势并引起反弹的失控。

e) 不要附装上锯链、木雕刀片或带齿锯片。这些锯片会产生频繁的反弹和失控。

砂磨和切割操作的附加安全说明

对磨削和砂磨切割操作的专用安全警告：

a) 只使用所推荐的砂轮型号和为选用砂轮专门设计的护罩。不是为电动工具设计的砂轮不能充分得到防护，是不安全的。

b) 护罩必须牢固地装在电动工具上，且放置得最具安全性，只有最小的砂轮部分暴露在操作人面前。护罩帮助保护操作者免于受到爆裂砂轮碎片和偶然触及砂轮的危險。

c) 砂轮只用作推荐的用途。例如：不要用切割砂轮的侧面进行磨削。施加到砂轮侧面的力可能会使其碎裂。

- d)始终为所选砂轮选用未损坏的、有恰当规格和形状的砂轮法兰盘。合适的砂轮法兰盘支承砂轮可以减小砂轮破裂的可能性。切割砂轮的法兰盘可以不同于砂轮法兰盘。
- e)不要使用从大规格电动工具上用剩的磨损砂轮。用于大规格电动工具上的砂轮不适于较小规格工具的高速工况并可能会爆裂。

切割操作的附加安全说明

对砂轮切割操作的附加专用安全警告：

- a)不要“夹”住切割砂轮或施加过大的压力。不要试图做过深的切割。给砂轮施加过应力增加了砂轮在切割时的负载，容易缠绕或卡住，增加了反弹或砂轮爆裂的可能性。
- b)身体不要对着旋转砂轮，也不要站在其后。当把砂轮从操作者身边的操作点移开时，可能的反弹会使旋转砂轮和电动工具朝你推来。
- c)当砂轮被卡住或无论任何原因而中断切割时，关掉电动工具并握住工具不要动，直到砂轮完全停止。决不要试图当砂轮仍然运转时使切割砂轮脱离切割，否则会发生反弹。调查并采取校正措施以消除砂轮卡住的原因。
- d)不能在工件上重新启动切割操作。让砂轮达到全速后再小心地重新进入切割。如果电动工具在工件上重新启动，砂轮可能会卡住、爬出或反弹。
- e)支撑住板材或超大工件可使得砂轮卡住和反弹的危险降到最低限度。大工件凭借自重而下垂。必须在工件靠近切割线处和砂轮两侧近工件边缘处放置支承。
- f)当进行“盲切割”进入墙体或其它盲区时要格外小心。伸出的砂轮可能会割到煤气管或水管，电线或由此引起反弹的物体。

砂光操作的附加安全说明：

砂光操作的专用安全警告：

- a)当砂光时，不要使用超大砂盘纸。选用砂盘纸时应按照制造商的推荐。超出砂光垫盘的大砂盘纸有撕裂的危险并且会引起缠绕、砂盘的撕裂或反弹。

钢丝刷操作的附加安全说明：

钢丝刷操作的专用安全警告：

- a)要意识到即使正常操作时钢丝线也会随刷子甩出。不要对钢丝刷施加过大的负荷而使得钢丝线承受过应力。钢丝线可能会轻易刺入薄的衣服和/或皮肤内。
- b)如果建议钢丝刷使用护罩，则不允许该护罩对钢丝轮或钢丝刷有任何干扰。钢丝轮或钢丝刷在工作负荷和离心力作用下直径会变大。

砂轮机附加特殊安全规定

- 砂轮必须一直配备恰当的防护装置。防护装置可防止破碎的砂轮颗粒伤到操作人员并且防止砂轮碰到操作人员。
- 附件的额定速度必须至少达到工具警示牌的推荐速度。如果砂轮和其它附件的旋转速度超过额定速度，可能会分离飞出，造成伤害。参考下表。附件的额定值须超过工具额定空载速度，因为工具实际速度是变化的。

说明：工具额定空载转速印在铭牌上，并且压印在齿轮壳上。

- 切割工具可能会接触到隐线或其自身的电缆线，因此在进行作业时，必须握住工具的绝缘夹持面。工具如果与带电电线接触会使工具的外露金属部件带电，从而使操作人员触电。
 - 每次使用前应检查推荐的附件是否有裂纹或瑕疵。如果有明显的裂纹或瑕疵，丢弃该附件。如果你认为工具可能跌落过，也必须检查附件。
 - 如果工具砂轮是新的、刚替换的，或者刚安上新、替换的钢丝刷，请在有一个周密保护的空間握住工具，让其运转一分钟以上。如果砂轮有难以察觉的裂缝或瑕疵，那么该砂轮会在几分钟内爆裂。如果钢丝刷有松脱的钢丝，就会被发现。严禁在有人(包括操作人员本人在内)与砂轮之间成一直线时启动工具。
 - 请勿猛撞砂轮或者粗暴使用砂轮。如果出现这种情况，请关闭工具进行检查。
 - 防止火星碰到操作人员、旁观者或易燃物品。工具在切割或研磨时，可能会产生火星。这些火星可能会导致(人员)烫伤或引发火灾。
 - 请一直使用并且紧握侧手柄。无论什么时候，都必须一直使用侧手柄来保持对工具的控制。
- ▲ 注意：**打磨边角时应格外当心，因为在砂轮接触第二平面时，砂轮机会突然急剧地移动。
- 请经常清洁您的工具，尤其是在经过繁重使用后。含有金属微粒的粉尘经常会沉积在工具的内表面，从而产生电击风险。
- ▲ 注意：**在使用工具时，请佩带恰当的个人听力保护装置。在某

些情况下以及长期使用本产品时，本产品所产生的噪音可能会影响听力。

▲ 警告：由电动打磨、切割、研磨、钻孔和其它一些建筑活动所产生的某些灰尘包含一些致癌、导致不育或其他生殖性疾病的化学物质。此类化学物质中的一些例子有：

- 铅基油漆中的铅
- 砖石、水泥和其它砖石结构产品中所含的石英
- 经过化学品处理的木材 (CCA) 中所含有的砷和铬

您接触这些物质的风险取决于您从事此类工作的频率。为了降低接触这些化学物质的风险：保持工作场所通风良好、采用认可的安全防护装备，例如过滤细微颗粒的专用防尘面具。

- 避免与电动打磨、切割、研磨、钻孔和其它一些建筑活动所产生的灰尘有过长的接触。穿戴防护服并且用水和肥皂清洗外露表面。如让灰尘进入您的口、眼或停留在皮肤上可能会促进对有害化学物品的吸收。

- 您工具上的铭牌可能会包含如下符号。

V.....电压	A.....安培
Hz.....赫兹	W.....瓦特
min.....分钟	~.....交流电
===直流电	n_0空载速度
□.....双重绝缘	.../min.....每分钟转数或
⊕.....接地终端	往复次数
▲.....安全小心标志	

熟悉工具

大型角向砂轮机 and 大型角向磨光机适用于金属切削等扩展应用的重型作业。本说明书描述的磨光机和砂轮机如下：

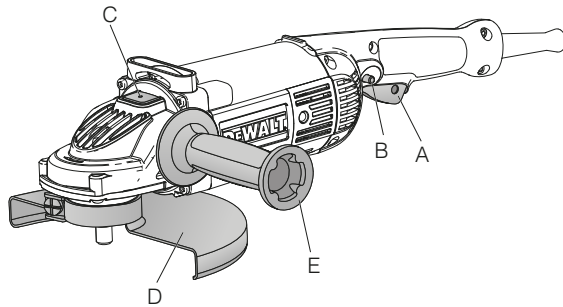

部件名称

- A. 触发开关
- B. 锁定按钮
- C. 主轴锁
- D. 防护装置
- E. 侧手柄
- F. 电源线

特点

开关
此工具通过触发开关(A)来控制。锁定按钮(B)在扩展应用时增加舒适性。

多位置侧手柄

侧手柄可以根据个人习惯以及实际应用适当地安装在两个位置。必须一直使用侧手柄来保持对工具的控制。

主轴锁

主轴锁销用于防止主轴在安装和卸下轮子时转动。只有当关闭电源，拔掉插头后，才可启动主轴锁。如欲啮合主轴锁，请按下主轴锁按钮(C)并转动主轴直到主轴不能转动为止。

说明：在工具处于作业状态时，切勿按下主轴锁按钮；在按下主轴锁按钮时，禁止启动工具，否则会给工具造成损伤。

托板

磨光机配有托板，便于装卸砂轮。

配件与附件

为磨光机选择正确的防护装置、衬垫和凸缘至关重要。参见第14页表格来正确选择配件。

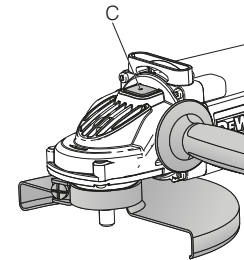

▲ 注意：附件的额定速度必须至少达到工具警示牌的推荐速度。
如果砂轮和其它附件的旋转速度超过额定速度，可能会分离飞出，造成伤害。

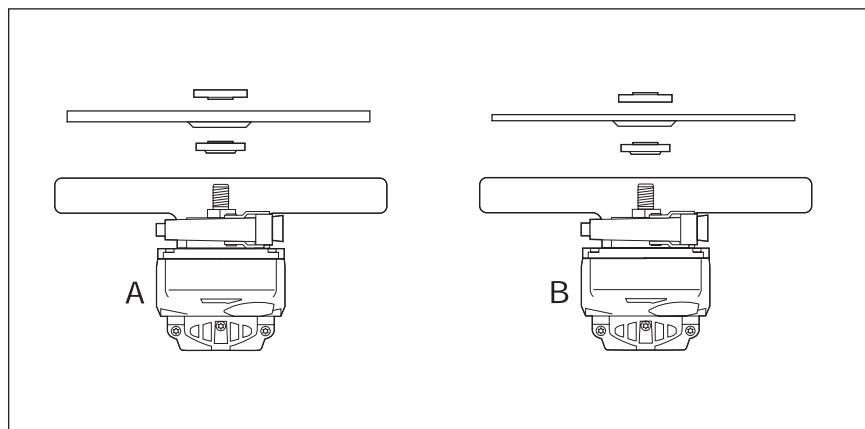

说明：砂轮尺寸必须匹配防护装置的尺寸；即，230mm新砂轮不可以使用9"防护装置。
砂轮底面必须位于弯曲的防护凸缘内部。

安装与调节

安装侧手柄

安装侧手柄时，把手柄旋入两个孔中的一个，并沿顺时针方向拧紧。

操作

电源

把大型角向磨光机插接到专用电路上。与其它工具共用电路会降低工具性能。

开关

▲ 注意：工具与电源连接前或者在停电后，请按压触发开关(A)后松开一次，不要按锁定按钮(B)，以确保开关处于“OFF”（关）状态。如果触发开关被锁定，在接通电源时，工具会意外起动。请紧握侧手柄及后手柄，保持起动和使用过程中对工具的控制。使用侧手柄来维持对工具的控制。

触发开关的操作

要启动工具，按下触发开关(A)。在触发开关处于按下状态时，工具保持运转。松开触发开关，工具停止运行。

触发操作与锁定特性

要启动工具，按下触发开关。在松开触发开关的同时，按下并保持锁定按钮(B)。持锁定按钮将保持按下状态，工具持续工作。

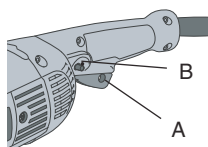
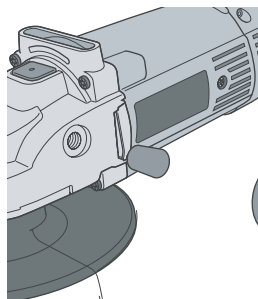

要关闭工具，按下并松开触发开关。锁定销会自动弹出，允许触发开关脱离并关闭工具。

说明：接触工作面前，让磨轮保持全速运动。关闭工具前，将工具从工作面上举起。

▲ 注意：在放下工具前，应确保磨轮完全停止转动。

排除锁定特性

锁定特性可以永久排除，而且不影响工具铭牌上规定的效力。锁定销的拆除必须由得伟服务中心进行。

凹心磨轮及平盘砂轮的安装与使用

安装和卸下防护装置

在进行任何调试、卸下或安装附件之前，请关闭电源并拔开工具的插头。工具重新接通电源前，请按下并松开触发开关以确保切断工具电源。

关于防护装置的重要信息

所有的磨轮、砂轮片、钢丝刷以及钢丝轮必须使用防护装置。防护罩锁紧扭力不得少于4.5NM，以防止使用意外造成伤害。只有在使用传统砂轮片打磨时，工具可以不带防护装置。

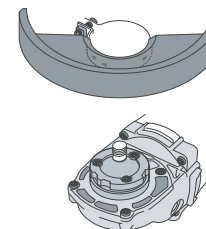

▲ 注意：在使用配有防护装置的砂轮时，砂轮底面必须位于弯曲的防护凸缘内部。

无轂砂轮的安装

凹心砂轮必须与配件凸缘一起使用。参阅本说明书第5页了解更多信息。

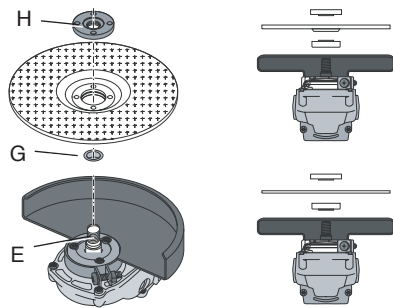

1. 安装金属衬垫凸缘(G)到主轴(E)并支撑到安装垫上。
2. 将砂轮对准衬垫凸缘，并且使砂轮与衬垫凸缘导向的中心对准。
3. 在按下主轴锁的同时，把锁紧螺母(H)拧到主轴上。引导锁紧螺母上的凸轂进入砂轮中心。
4. 使用扳手紧固锁紧螺母。
5. 要拆除砂轮，反向操作以上步骤。

用砂轮进行平面磨削操作

1. 在工具与工件表面接触之前，必须确保本工具以全速运转。
2. 请向工件表面施加最小压力，这样可确保电动工具能够高速运转。
3. 工具和工件表面之间保持 20° 至 30° 的角度。
4. 以前后运动方向持续不断的移动本工具，这样可防止在工件表面产生凿槽(孔)。
5. 在关闭工具之前，先将工具从工件表面移开。在放下工具之前，必须先确保工具停止旋转。
6. 建议用户采用得伟原装砂轮片；并选用标称最大转速1.1倍的砂轮片。

用砂轮进行磨边操作

▲ 注意：在工具进行切割作业或深磨作业时，用于切割或磨边作业的砂轮，如果被弯曲或扭曲，那么可能会爆裂。为了降低出现严重伤害的风险，必须用标准的防护装置来限制此类砂轮的使用，使其只能进行浅度切割和开槽作业(深度不到0.5英寸)。防护装置开口面的定位不能对着操作人员。如欲用切割轮进行深度切割，那么请使用密闭型的防护装置。您可从本地经销商处或特约维修中心处另外付费购买到防护装置。

1. 在工具与工件表面接触之前，必须确保工具以全速运转。
2. 请向工件表面施加最小压力，这样可确保电动工具能够高速运转。
3. 请注意磨边时的自我保护，不要让防护装置的开口对着您。
4. 以前后运动方向持续不断的移动本工具，这样可防止在工件表面产生凿槽(孔)。
5. 在关闭工具之前，先将工具从工件表面移开。在放下工具之前，必须先确保工具停止旋转。

▲ 警告：请勿将磨边/切割砂轮用于平面磨削场合，因为这些砂轮自身的设计构造并不足以抗受平面磨削所产生的侧压。如果这样，砂轮可能会爆裂，而且可能会有出现伤害情况。

翼片砂轮抛光

1. 在工具与工件表面接触之前，必须确保本工具以全速运转。
2. 请向工件表面施加最小压力，这样可确保电动工具能够高速运转。
3. 工具和工件表面之间保持5°至10°的角度。
4. 以前后运动方向持续不断的移动本工具，这样可防止在工件表面产生凿槽(孔)。
5. 在关闭工具之前，先将工具从工件表面移开。在放下工具之前，必须先确保工具停止旋转。

切割轮的安装和使用

切割轮包括金刚石砂轮和研磨砂轮盘。也供应有金属和水泥应用场合所需的研磨切片。此外，金刚石切片也可以使用于水泥切割场合。

▲ 警告：本工具并不包括密闭型的切片防护装置。但是在使用切片时必须要有正确的凸缘和防护装置。可以提供180mm切割防护装置作为配件，这包括合适的配套凸缘。如果没有使用恰当的凸缘和防护装置，那么由于砂轮爆裂和轮片接触现象，可能会出现伤害情况。

密闭型防护装置的安装

在进行调整、更换附件之前，请关闭工具并将工具的插头从电源插座中拔开。在重新接通工具电源之前，请按下并松开触发开关，确保工具处于关闭状态。

1. 将凸耳与齿轮箱上的槽对中。把防护装置向后定位，如图所示。
2. 下压防护装置直到其凸耳啮合在齿轮箱轂的槽里，并在齿轮箱轂上自由旋转。
3. 将防护装置旋转至需要的工作部位。防护装置主体的定位必须位于主轴和操作人员之间，这样可为操作人员提供最大限度的保护。
4. 将防护装置固定在齿轮箱箱盖上。如果插销处于闭合位置，那么您应当无法用手转动防护装置。如果防护装置并没有固定紧，或者夹紧把手处于打开位置，那么请勿启动研磨机。

说明：防护装置在出厂时已经预先根据齿轮箱的轂直径调准。如果使用一段时期后，防护装置松动，请将调节螺丝紧固。

切割砂轮的安装

1. 卸下安装垫。
2. 安装砂轮衬垫凸缘，将主轴平面与衬垫凸缘平面对正。
3. 将砂轮放到衬垫凸缘上，把砂轮和衬垫凸缘的导向中心对正。
4. 装上锁紧螺母，确保砂轮与衬垫凸缘对心。
5. 按下主轴锁紧按钮并用扳手紧固锁紧螺母。
6. 要拆除砂轮，反向操作以上步骤。

使用切割轮

1. 在工具与工作表面接触之前，请保持工具全速转动。
2. 对工作表面施加最小压力，确保工具可高速作业。
3. 一旦切割开始，请不要改变砂轮与工件表面的切割角度。改变切割角度会导致砂轮弯曲并可能会导致砂轮爆裂、人身伤害。

4. 在关闭工具电源之前就将工具与工作表面分离。在将工具放下之前必须确保工具停止转动。

维护 清洁

利用清洁干燥的压缩空气吹走马达和开关启动器中的灰尘和沙砾，这是必须定期进行的维护流程。含有金属颗粒的灰尘和沙砾常常累积在内表面，如果不定期清除干净，则可能会导致电击或触电。必须一直佩带护目镜。

▲ 注意：切勿使用溶剂或其它刺激性化学品清洁工具的非金属部件。只能使用洁净干燥的抹布。

润滑

得伟电动工具在出厂之前已完全润滑，即可使用。

修理

为确保产品的安全性和可靠性，修理、维护和调整工作均必须由授权的服务中心或其它合格的维护人员进行。必须一直使用同一替换部件。

马达碳刷

碳刷磨短时，工具自动关闭，避免损坏马达。碳刷更换工作必须由得伟授权的服务中心或其它合格的维护人员进行。在更换碳刷时，合格的维护人员应该遵守下列程序。

在进行调整、更换附件之前，请关闭工具并将工具的插头从电源插座中拔开。在重新接通工具电源之前，请按下并松开触发开关，确保工具处于关闭状态。

1. 取下马达外壳侧面的碳刷盖。
2. 要取下碳刷，先夹住连接碳刷引线的阴接头，然后把阴接头从阳接头中拆开。
3. 从碳刷座上直拉并取出碳刷。
4. 成对更换来自得伟授权的服务中心的碳刷。
5. 确保碳刷在碳刷架内自由滑动。
6. 重新连接碳刷引线到碳刷终端盒。
7. 使用工具前装回碳刷盖。施加到螺钉的最大拧紧扭矩为10 in-lbs。拧紧过度会导致螺钉脱落。

配件采购

自本地经销商或授权服务中心处获得的推荐使用的配件，需另外付费。

▲ 注意：如果本工具使用任何其它非推荐配件，可能会有危险。

制造商名称：百得（苏州）科技有限公司
制造商地址：苏州工业园区苏虹中路200号出口加工区

N442563

06/2015