

DEWALT®

www.DEWALT.com

D25832

English

3

简体中文

8

Fig. A
图 A

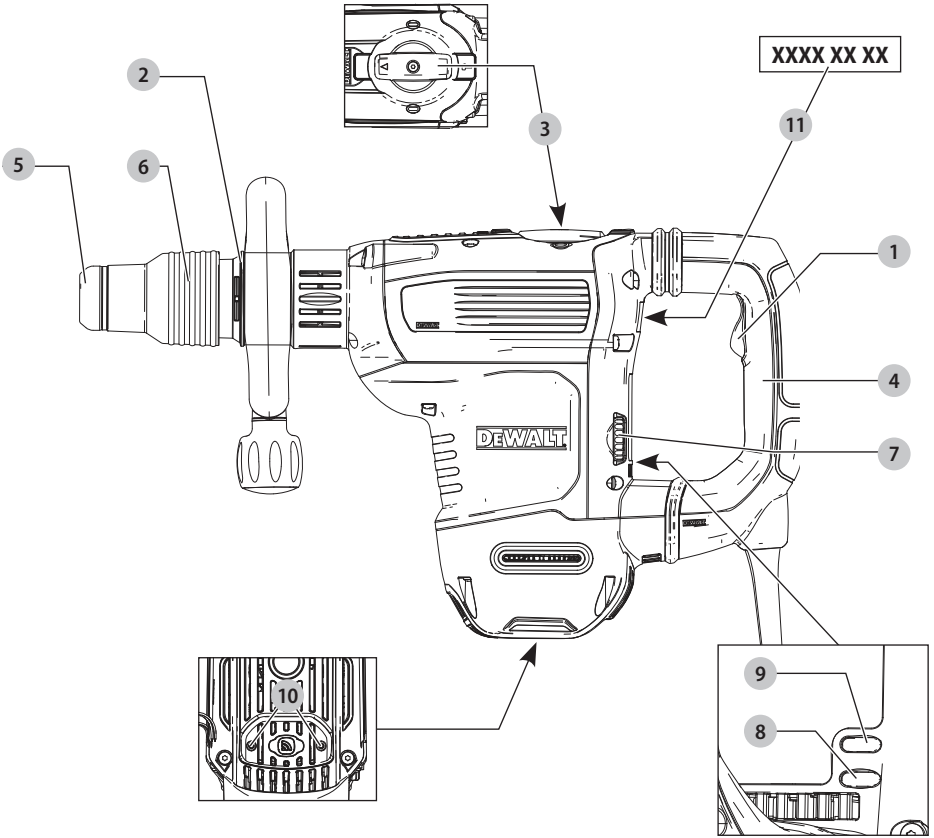

Fig. B
图 B

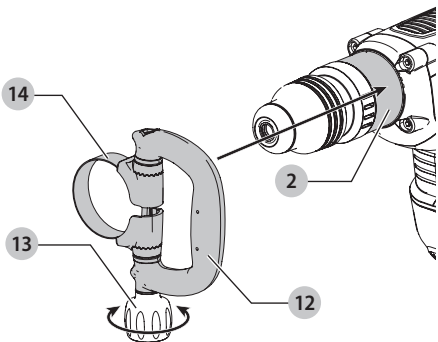

Fig. C
图 C

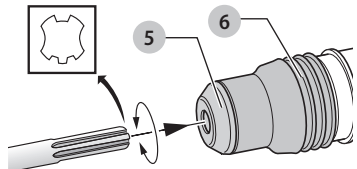
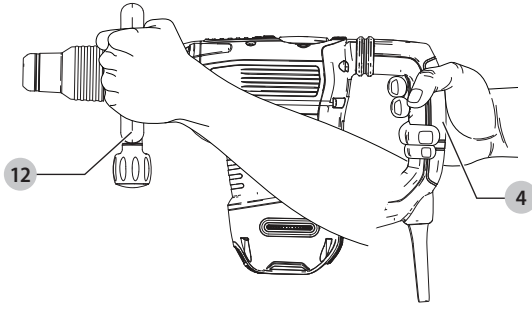

Fig. D
图 D



HEAVY-DUTY CHIPPING HAMMER

D25832

Congratulations!

You have chosen a DEWALT tool. Years of experience, thorough product development and innovation make DEWALT one of the most reliable partners for professional power tool users.

Technical Data

		D25832
Voltage	V _{AC}	220-240
Frequency	Hz	50/60
Power Input	W	1350
No-load beats per minute	bpm	1450–2900
Single impact energy (EPTA 05/2009)	J	10.5
Tool holder		SDS MAX
Weight (including handle)	kg	7.4



WARNING: To reduce the risk of injury, read the instruction manual.

Definitions: Safety Guidelines

The definitions below describe the level of severity for each signal word. Please read the manual and pay attention to these symbols.



DANGER: Indicates an imminently hazardous situation which, if not avoided, **will** result in **death or serious injury**.



WARNING: Indicates a potentially hazardous situation which, if not avoided, **could** result in **death or serious injury**.



CAUTION: Indicates a potentially hazardous situation which, if not avoided, **may** result in **minor or moderate injury**.

NOTICE: Indicates a practice **not related to personal injury** which, if not avoided, **may** result in **property damage**.



Denotes risk of electric shock.



Denotes risk of fire.

GENERAL POWER TOOL SAFETY WARNINGS



WARNING: Read all safety warnings, instructions, illustrations and specifications provided with this power tool. Failure to follow all instructions listed below may result in electric shock, fire and/or serious injury.

SAVE ALL WARNINGS AND INSTRUCTIONS FOR FUTURE REFERENCE.

The term "power tool" in the warnings refers to your mains-operated (corded) power tool or battery-operated (cordless) power tool.

1) Work Area Safety

- Keep work area clean and well lit.** Cluttered or dark areas invite accidents.
- Do not operate power tools in explosive atmospheres, such as in the presence of flammable liquids, gases or dust.** Power tools create sparks which may ignite the dust or fumes.
- Keep children and bystanders away while operating a power tool.** Distractions can cause you to lose control.

2) Electrical Safety

- Power tool plugs must match the outlet. Never modify the plug in any way. Do not use any adapter plugs with earthed (grounded) power tools.** Unmodified plugs and matching outlets will reduce risk of electric shock.
- Avoid body contact with earthed or grounded surfaces, such as pipes, radiators, ranges and refrigerators.** There is an increased risk of electric shock if your body is earthed or grounded.
- Do not expose power tools to rain or wet conditions.** Water entering a power tool will increase the risk of electric shock.
- Do not abuse the cord. Never use the cord for carrying, pulling or unplugging the power tool. Keep cord away from heat, oil, sharp edges or moving parts.** Damaged or entangled cords increase the risk of electric shock.
- When operating a power tool outdoors, use an extension cord suitable for outdoor use.** Use of a cord suitable for outdoor use reduces the risk of electric shock.
- If operating a power tool in a damp location is unavoidable, use a residual current device (RCD) protected supply.** Use of an RCD reduces the risk of electric shock.

3) Personal Safety

- Stay alert, watch what you are doing and use common sense when operating a power tool. Do not use a power tool while you are tired or under the influence of drugs, alcohol or medication.** A moment of inattention while operating power tools may result in serious personal injury.
- Use personal protective equipment. Always wear eye protection.** Protective equipment such as a dust mask, non-skid safety shoes, hard hat or hearing protection used for appropriate conditions will reduce personal injuries.
- Prevent unintentional starting. Ensure the switch is in the off-position before connecting to power source and/or battery pack, picking up or carrying the tool.** Carrying power tools with your finger on the switch or energising power tools that have the switch on invites accidents.
- Remove any adjusting key or wrench before turning the power tool on.** A wrench or a key left attached

to a rotating part of the power tool may result in personal injury.

- e) **Do not overreach. Keep proper footing and balance at all times.** This enables better control of the power tool in unexpected situations.
- f) **Dress properly. Do not wear loose clothing or jewellery. Keep your hair and clothing away from moving parts.** Loose clothes, jewellery or long hair can be caught in moving parts.
- g) **If devices are provided for the connection of dust extraction and collection facilities, ensure these are connected and properly used.** Use of dust collection can reduce dust-related hazards.
- h) **Do not let familiarity gained from frequent use of tools allow you to become complacent and ignore tool safety principles.** A careless action can cause severe injury within a fraction of a second.

4) Power Tool Use and Care

- a) **Do not force the power tool. Use the correct power tool for your application.** The correct power tool will do the job better and safer at the rate for which it was designed.
- b) **Do not use the power tool if the switch does not turn it on and off.** Any power tool that cannot be controlled with the switch is dangerous and must be repaired.
- c) **Disconnect the plug from the power source and/or remove the battery pack, if detachable, from the power tool before making any adjustments, changing accessories, or storing power tools.** Such preventive safety measures reduce the risk of starting the power tool accidentally.
- d) **Store idle power tools out of the reach of children and do not allow persons unfamiliar with the power tool or these instructions to operate the power tool.** Power tools are dangerous in the hands of untrained users.
- e) **Maintain power tools and accessories. Check for misalignment or binding of moving parts, breakage of parts and any other condition that may affect the power tool's operation. If damaged, have the power tool repaired before use.** Many accidents are caused by poorly maintained power tools.
- f) **Keep cutting tools sharp and clean.** Properly maintained cutting tools with sharp cutting edges are less likely to bind and are easier to control.
- g) **Use the power tool, accessories and tool bits etc. in accordance with these instructions, taking into account the working conditions and the work to be performed.** Use of the power tool for operations different from those intended could result in a hazardous situation.
- h) **Keep handles and grasping surfaces dry, clean and free from oil and grease.** Slippery handles and grasping surfaces do not allow for safe handling and control of the tool in unexpected situations.

5) Service

- a) **Have your power tool serviced by a qualified repair person using only identical replacement parts.** This will ensure that the safety of the power tool is maintained.

Additional Safety Instructions for Chipping Hammers

- **Wear ear protectors.** Exposure to noise can cause hearing loss.
- **Use auxiliary handle supplied with the tool.** Loss of control can cause personal injury.
- **Hold power tool by insulated gripping surfaces, when performing an operation where the cutting accessory may contact hidden wiring or its own cord.** Cutting accessory contacting a "live" wire may make exposed metal parts of the power tool "live" and could give the operator an electric shock.
- **Use clamps or other practical way to secure and support the workpiece to a stable platform.** Holding the work by hand or against your body is unstable and may lead to loss of control.
- **Wear safety goggles or other eye protection.** Hammering operations cause chips to fly. Flying particles can cause permanent eye damage. Wear a dust mask or respirator for applications that generate dust. Ear protection may be required for most applications.
- **Keep a firm grip on the tool at all times.** Do not attempt to operate this tool without holding it with both hands. It is recommended that the side handle be used at all times. Operating this tool with one hand will result in loss of control. Breaking through or encountering hard materials such as re-bar may be hazardous as well. Tighten the side handle securely before use.
- **Do not operate this tool for long periods of time.** Vibration caused by hammer action may be harmful to your hands and arms. Use gloves to provide extra cushion and limit exposure by taking frequent rest periods.
- **Do not recondition bits yourself.** Chisel reconditioning should be done by an authorized specialist. Improperly reconditioned chisels could cause injury.
- **Wear gloves when operating tool or changing bits.** Accessible metal parts on the tool and bits may get extremely hot during operation. Small bits of broken material may damage bare hands.
- **Never lay the tool down until the bit has come to a complete stop.** Moving bits could cause injury.
- **Do not strike jammed bits with a hammer to dislodge them.** Fragments of metal or material chips could dislodge and cause injury.
- **Slightly worn chisels can be resharpened by grinding.**
- **Keep the power cord away from the bit.** Do not wrap the cord around any part of your body. An electric cord wrapped around a spinning bit may cause personal injury and loss of control.



WARNING: We recommend the use of a residual current device with a residual current rating of 30mA or less.

Residual Risks

In spite of the application of the relevant safety regulations and the implementation of safety devices, certain residual risks cannot be avoided. These are:

- Impairment of hearing.
- Risk of personal injury due to flying particles.
- Risk of burns due to accessories becoming hot during operation.
- Risk of personal injury due to prolonged use.

SAVE THESE INSTRUCTIONS ELECTRICAL SAFETY

The electric motor has been designed for one voltage only. Always check that the power supply corresponds to the voltage on the rating plate.



Your DEWALT tool is double insulated in accordance with IEC60745; therefore no earth wire is required.

If the supply cord is damaged, it must be replaced only by DEWALT or an authorised service organisation.

Using an Extension Cable

If an extension cable is required, use an approved 3-core extension cable suitable for the power input of this tool (see **Technical Data**). The minimum conductor size is 1.5 mm²; the maximum length is 30 m.

When using a cable reel, always unwind the cable completely.

Package Contents

The package contains:

- 1 Chipping hammer
- 1 Side handle
- 1 Instruction manual
- Check for damage to the tool, parts or accessories which may have occurred during transport.
- Take the time to thoroughly read and understand this manual prior to operation.

Markings on Tool

The following pictograms are shown on the tool:



Read instruction manual before use.



Wear ear protection.



Wear eye protection.

Date Code Position (Fig. A)

The date code **11**, which also includes the year of manufacture, is printed into the housing.

Example:

2019 XX XX

Year of Manufacture

Description (Fig. A)



WARNING: Never modify the power tool or any part of it. Damage or personal injury could result.

- | | |
|-------------------------|--|
| 1 ON/OFF rocker switch | 7 Electronic speed and impact control dial |
| 2 Front Barrel (Collar) | 8 Red service indicator LED |
| 3 Mode selector dial | 9 Yellow brushwear indicator LED |
| 4 Main handle | 10 DEWALT tool tag mounting holes |
| 5 Tool holder | 11 Date code |
| 6 Locking sleeve | |

Intended Use

Your chipping hammer has been designed for professional chiseling and chipping applications.

DO NOT use under wet conditions or in the presence of flammable liquids or gases.

Your chipping hammer is a professional power tool.

DO NOT let children come into contact with the tool. Supervision is required when inexperienced operators use this tool.

- **Young children and the infirm.** This appliance is not intended for use by young children or infirm persons without supervision.
- This product is not intended for use by persons (including children) suffering from diminished physical, sensory or mental abilities; lack of experience, knowledge or skills unless they are supervised by a person responsible for their safety. Children should never be left alone with this product.

Active Vibration Control (AVC) System

For best vibration control, hold the tool as described in **Proper Hand Position** and apply just enough pressure so the damping device on the main handle is approximately mid stroke.

The active vibration control neutralises rebound vibration from the hammer mechanism. Lowering hand and arm vibration, it allows more comfortable use for longer periods of time and extends the life of the unit.

The hammer only needs enough pressure to engage the active vibration control. Applying too much pressure will not make the tool chip faster and active vibration control will not engage.

DEWALT Tool Tag Ready (Fig. A)

Optional Accessory

Your hammer comes with DEWALT tool tag mounting holes **10** and fasteners for installing a DEWALT Tool Tag. You will need a T15 bit tip to install the tag. The DEWALT Tool Tag is designed for tracking and locating professional power tools, equipment, and machines using the DEWALT Tool Connect™ app. For proper installation of the DEWALT Tool Tag refer to the DEWALT Tool Tag manual.



Electronic Speed and Impact Control (Fig. A)

The electronic speed and impact control allows optimal tool control for precise chiseling.

To set the electronic speed and impact control dial **7**, turn the dial to the desired level. The higher the number, the greater the speed and impact energy. Dial settings make the tool extremely flexible and adaptable for many different applications. The required setting depends on the bit size and hardness of material being chiseled.

- When chiselling soft, brittle materials or when minimum break-out is required, set the dial to a low setting;
- When breaking harder materials, set the dial to a high setting.

Service Indicator LEDs (Fig. A)

LED Function	Description
 Red (flashing)	Service The red service indicator LED 8 flashes if there is a fault with the tool or the brushes have completely worn out.
 Yellow (permanently on)	Brush Service The yellow brushwear indicator LED 9 lights up when the carbon brushes are nearly worn out to indicate that the tool needs servicing within the next 8 hours of use.

ASSEMBLY AND ADJUSTMENTS

 **WARNING:** To reduce the risk of serious personal injury, turn tool off and disconnect tool from power source before making any adjustments or removing/installing attachments or accessories. An accidental start-up can cause injury.

Side Handle (Fig. B)

 **WARNING:** To reduce the risk of personal injury, ALWAYS operate the tool with the side handle properly installed. Failure to do so may result in the side handle slipping during tool operation and subsequent loss of control. Hold tool with both hands to maximize control.

The side handle **12** clamps to the front of the gear case and may be rotated 360° to permit right- or left-hand use.

Mounting the Side Handle Assembly (Fig. B)

1. Widen the ring opening **14** of the side handle **12** by rotating the screw for side handle mounting **13** counterclockwise.
2. Slide the assembly onto the nose of the tool, through the steel ring **14** and onto the collar **2**, past the chisel holder and sleeve.
3. Rotate the side handle assembly to the desired position.
4. Lock the side handle mounting assembly in place by securely tightening the screw for side handle mounting **13** rotating it clockwise so that the assembly will not rotate.

Bit and Bit Holder

 **WARNING:** Burn Hazard. ALWAYS wear gloves when changing bits. Accessible metal parts on the tool and bits may get extremely hot during operation. Small bits of broken material may damage bare hands.

 **WARNING:** Do not attempt to tighten or loosen chisel bits (or any other accessory) by gripping the front part of the chuck and turning the tool on. Damage to the chuck and personal injury may occur.

The chipping hammer can be fitted with various chisel bits depending on the desired application. **Use sharp bits only.**

Inserting and Removing SDS MAX Bits (Fig. C)

NOTE: Accessories and attachments used must be lubricated around the SDS fitment before installation.

1. Pull back the locking sleeve **6** and insert the bit shank. The bit shank must be clean.
2. Turn the bit slightly until the sleeve snaps back into position.
3. Ensure the bit is properly engaged.
NOTE: The bit needs to move several centimeters in and out of the tool holder **5** when properly engaged.
4. To remove the bit, pull back the locking sleeve and pull the bit out.

Bit Position Adjustment

Turn the mode selector to bit adjustment icon (Refer to **Mode Selection**) to adjust the chisel to the desired position. There are multiple positions to set the angle of the chisel.

NOTE: After finding the desired position, slightly maneuver the chisel bit back and forth to ensure the chisel is properly engaged.

OPERATION

Instructions for Use

 **WARNING:** Always observe the safety instructions and applicable regulations.

 **WARNING:** To reduce the risk of serious personal injury, turn tool off and disconnect tool from power source before making any adjustments or removing/installing attachments or accessories. An accidental start-up can cause injury.

Proper Hand Position (Fig. D)

 **WARNING:** To reduce the risk of serious personal injury, ALWAYS use proper hand position as shown.



 **WARNING:** To reduce the risk of serious personal injury, ALWAYS hold securely in anticipation of a sudden reaction.

Proper hand position requires one hand on the mounted side handle **12**, with the other hand on the main handle **4**.

Mode Selection (Fig. A)

 **WARNING:** Do not select the operating mode when the tool is running. Tool must come to a complete stop before activating the mode selector button or damage to the tool may result.

Your tool is equipped with a mode selector dial **3** to select the mode appropriate to desired operation.

Symbol	Mode	Application
	Bit Adjustment	Chisel bit position adjustment
	Hammering/Chipping	Light chipping, chiseling and demolition

To Select a Mode

- Rotate the mode selector dial so that the arrow points to the symbol corresponding for the desired mode.

NOTE: The arrow on the mode selector dial **3** must be pointing at a mode symbol at all times. There are no operable positions in between.

Indexing the Chisel Position (Fig. A)

The chisel can be indexed and locked into 18 different positions.

1. Rotate the mode selector switch **3** until it points towards the **1** position.
2. Rotate the chisel in the desired position.
3. Set the mode selector switch **3** to the "Hammering/Chipping" position.
4. Twist the chisel until it locks in position.

Performing an Application (Fig. A, B)

 **WARNING: TO REDUCE THE RISK OF PERSONAL INJURY, ALWAYS ensure workpiece is anchored or clamped firmly.**

NOTE: Operating temperature of this tool is 7° C to +40° C. Using the tool outside of this temperature range will decrease the life of the tool.

1. Insert the appropriate chisel and rotate it by hand to lock it into the desired position. Refer to **Bit and Bit Holder**.
2. Using the mode selector dial **3**, select chipping mode. Refer to **Mode Selection**.
3. Adjust the side handle **12** as necessary. Refer to **Mounting the Side Handle Assembly**.
4. Place the chisel on the desired location.
5. Depress the ON/OFF rocker switch **1**.
6. To stop the hammer, release the ON/OFF rocker switch.

MAINTENANCE

Your power tool has been designed to operate over a long period of time with a minimum of maintenance. Continuous satisfactory operation depends upon proper tool care and regular cleaning.

 **WARNING: To reduce the risk of serious personal injury, turn tool off and disconnect tool from power source before making any adjustments or removing/installing attachments or accessories. An accidental start-up can cause injury.**



Lubrication

Your power tool requires no additional lubrication.



Cleaning



WARNING: Blow dirt and dust out of the main housing with dry air as often as dirt is seen collecting in and around the air vents. Wear approved eye protection and approved dust mask when performing this procedure.



WARNING: Never use solvents or other harsh chemicals for cleaning the non-metallic parts of the tool. These chemicals may weaken the materials used in these parts. Use a cloth dampened only with water and mild soap. Never let any liquid get inside the tool; never immerse any part of the tool into a liquid.

Optional Accessories



WARNING: Since accessories, other than those offered by DEWALT, have not been tested with this product, use of such accessories with this tool could be hazardous. To reduce the risk of injury, only DEWALT recommended accessories should be used with this product.

Various types of SDS MAX chisels are available as an option. Accessories and attachments used must be regularly lubricated around the SDS MAX fitment.

Consult your dealer for further information on the appropriate accessories.

Protecting the Environment



Separate collection. Products marked with this symbol must not be disposed of with normal household waste. Products contain materials that can be recovered or recycled reducing the demand for raw materials. Please recycle electrical products according to local provisions. Further information is available at www.2helpU.com.

重型电锯

D25832

恭喜!

感谢您选购 DeWALT 工具。凭借多年的产品开发和创新经验，DeWALT 已经成为专业电动工具用户最可靠的合作伙伴之一。

技术参数

		D25832
电压	伏特 _{交流}	220
频率	赫兹	50
输入功率	瓦	1350
每分钟冲击数	bpm	1450–2900
冲击能量 (EPTA 05/2009)	J	10.5
工具夹持器		SDS MAX
重量 (包括手柄)	千克	7.4



警告: 为降低伤害风险，请阅读使用手册。

定义: 安全指南

下列定义描述了各标志术语的严重程度。请仔细阅读本手册，并注意这些标志。



危险: 表示存在紧急危险情况，如果不加以避免，将导致死亡或严重伤害。



警告: 表示存在潜在的危险情况，如果不加以避免，可能导致死亡或严重伤害。



警示: 表示存在潜在危险情况，如果不加以避免，可能导致轻度或中度伤害。

注意: 表示存在不涉及人身伤害的情况，如果不加以避免，可能导致财产损失。



表示存在触电风险。



表示存在火灾风险。

电动工具通用安全警告



警告! 阅读随电动工具提供的所有安全警告、说明、图示和规定。不遵照以下所列说明会导致电击、着火和/或严重伤害。

保存所有警告和说明书以备查阅。

警告中的术语“电动工具”指市电驱动(有线)电动工具或电池驱动(无线)电动工具。

a) 工作场地的安全

- 保持工作场地清洁和明亮。杂乱和黑暗的场地会引发事故。
- 不要在易燃易爆环境，如有易燃液体、气体或粉尘的环境下操作电动工具。电动工具产生的火花会点燃粉尘或气体。
- 操作电动工具时，远离儿童和旁观者。注意力不集中会让你失去对工具的控制。

b) 电气安全

- 电动工具插头必须与插座相配。绝不能以任何方式改装插头。需接地的电动工具不能使用任何转换插头。未经改装的插头和相配的插座将降低电击风险。

- 避免人体接触接地表面，如管道、散热片和冰箱。如果你身体接触接地表面会增加电击风险。
- 不得将电动工具暴露在雨中或潮湿环境中。水进入电动工具将增加电击风险。
- 不得滥用软线。绝不能用软线搬运、拉动电动工具或拔出其插头。使软线远离热源、油、锐边或运动部件。受损或缠绕的软线会增加电击风险。
- 当在户外使用电动工具时，使用适合户外使用的延长线。适合户外使用的电线将降低电击风险。
- 如果无法避免在潮湿环境下操作电动工具，应使用带有剩余电流装置(RCD)保护的电源。RCD的使用可降低电击风险。

c) 人身安全

- 保持警觉，当操作电动工具时关注所从事的操作并保持清醒。当你感到疲倦，或在有药物、酒精或治疗反应时，不要操作电动工具。在操作电动工具时瞬间的疏忽会导致严重人身伤害。
- 使用个人防护装置。始终佩戴护目镜。防护装置，诸如适当条件下使用防尘面具、防滑安全鞋、安全帽、听力防护等装置能减少人身伤害。
- 防止意外启动。在连接电源和/或电池盒、拿起或搬运工具前确保开关处于关断位置。手指放在开关上搬运工具或开关处于接通时通电会导致危险。
- 在电动工具接通之前，拿掉所有调节钥匙或扳手。遗留在电动工具旋转零件上的扳手或钥匙会导致人身伤害。
- 手不要过分伸展。时刻注意立足点和身体平衡。这样能在意外情况下能更好地控制住电动工具。
- 着装适当。不要穿宽松衣服或佩戴饰品。让你的头发和衣服远离运动部件。宽松衣服、配饰或长发可能会卷入运动部件。
- 如果提供了与排屑、集尘设备连接用的装置，要确保其连接完好且使用得当。使用集尘装置可降低尘屑引起的危险。
- 不要因为频繁使用工具而产生的熟悉感而掉以轻心，忽视工具的安全准则。某个粗心的动作可能在瞬间导致严重的伤害。

d) 电动工具使用和注意事项

- 不要勉强使用电动工具，根据用途使用合适的电动工具。选用合适的按照额定值设计的电动工具会使你工作更有效、更安全。
- 如果开关不能接通或关断电源，则不能使用该电动工具。不能通过开关来控制的电动工具是危险的且必须进行修理。
- 在进行任何调节、更换附件或贮存电动工具之前，必须从电源上拔掉插头和/或卸下电池包(如可拆卸)。这种防护性的安全措施降低了电动工具意外启动的风险。
- 将闲置不用的电动工具贮存在儿童所及范围之外，并且不允许不熟悉电动工具和不了解这些说明的人操作电动工具。电动工具在未经培训的使用者手中是危险的。
- 维护电动工具及其附件。检查运动部件是否调整到位或卡住，检查零件破损情况和影响电动工具运行的其他状况。如有损坏，应在使用前修理好电动工具。许多事故是由维护不良的电动工具引发的。

- 保持切削刀具锋利和清洁。维护良好地有锋利切削刃的刀具不易卡住而且容易控制。
- 按照使用说明书，并考虑作业条件和要进行的作业来选择电动工具、附件和工具的刀头等。将电动工具用于那些与其用途不符的操作可能会导致危险情况。
- 保持手柄和握持表面干燥、清洁，不得沾有油脂。在意外的情况下，湿滑的手柄不能保证握持的安全和对工具的控制。

e) 维修

- 1) 让专业维修人员使用相同的备件维修电动工具。这将保证所维修的电动工具的安全。
- 2) 决不能维修损坏的电池包。电池包仅能由生产者或其授权的维修服务商进行维修。

电锤专用警告语：

戴好耳罩。暴露在噪声中会引起听力损伤。

使用随工具提供的辅助手柄。操作失手会引起人身伤害。

当在切削附件可能触及暗线或其自身软线之处进行操作时，要通过绝缘握持面来握持工具。切削附件碰到带电导线会使工具外露的金属零件带电从而使操作者受到电击。

切削电锤的附加安全守则

- 使用夹具或采取其他可行的方法，将工件固定、支撑到稳定的平台上。手持或用身体顶住工件都是不稳定的，会导致操作失控。
- 请佩戴安全护目镜或其他护目装备。冲击操作会导致碎片飞散。飞散的颗粒会对眼睛造成永久性伤害。请在产生粉尘的应用环境佩戴防尘面具或口罩。大多应用环境需要佩戴听力保护器。
- 时刻紧握工具。切勿尝试在不使用双手握住工具时操作此工具。建议始终使用侧手柄。单手操作此工具会导致失控。穿透或遇到坚硬材料（如钢筋）也可能发生危险。使用前请务必稳固转紧侧手柄。
- 不要长时间操作此工具。锤击操作导致的振动可能会伤害您的手部和手臂。使用手套提供额外缓冲，经常停下休息，限制使用时间。
- 切勿自行整修钻头。凿子的整修工作应由授权专业人员来完成。凿子整修不当可能会导致伤害。
- 操作工具或更换钻头时请佩戴手套。工具和钻头上的可接触金属部件可能会在操作过程中变得非常热。少量破碎材料可能会导致双手受伤。
- 直到钻头完全停止运动才放下工具。运动钻头可能会导致伤害。
- 请勿使用锤子击打卡住的钻头。金属碎片或材料碎屑可能会弹出而导致伤害。
- 轻度磨损的凿子可通过打磨进行磨尖。
- 让电线远离钻头。请勿用身体的任何部位缠绕电线。缠绕在旋转中的钻头周围的电线可能会导致人身伤害和失控。

警告：我们建议使用漏电保护额定电流为 30 毫安或以下的漏电保护装置。

剩余风险

尽管遵守了相关的安全法规并采用了安全装备，某些剩余风险仍然是无法避免的。这些风险包括：

- 听力损伤。
- 飞溅颗粒造成的人身伤害风险。

- 使用时附件发热导致的灼伤风险。
- 长时间使用引起的人身伤害风险。

请妥善保管好这些说明

电气安全

电机只适用一种工作电压。请务必检查电源电压是否与铭牌上的电压一致。



您的 DeWALT 工具依据 IEC60745 标准设置双重绝缘，因此无须接地线。

如果电源线损坏，必须仅通过 DeWALT 或授权服务机构进行更换。

使用延长线

如需使用延长电缆，请使用与本工具的输入功率（见**技术参数**）匹配的经验 3 芯延长线。最小导体尺寸为 1.5 平方毫米，最大长度为 30 米。使用电缆卷筒时，请务必拉出所有的电缆。

包装内的物品

包装内的物品包括：

- 1 只 电锤
- 1 只 侧手柄
- 1 本 说明手册

- 检查工具、部件或附件是否在运输过程中损坏。
- 操作前，请抽空仔细阅读并掌握本手册。

工具上的标记

工具上印有下列图形：



使用前请阅读使用手册。



请佩戴听力保护器。



请佩戴护目装备。

日期代码位置 (图 A)

包含制造年份的日期码 **11** 打印在工具外壳上。

示例：

2019 XX XX
制造年份

说明 (图 A)

警告：切勿改装本电动工具或其任何部件，否则可能会导致损坏或人身伤害。

- | | |
|-----------|-------------------|
| 1 翘板开关 | 7 电子变速器和冲击控制旋钮 |
| 2 前筒 (轴环) | 8 红色维修 LED 指示灯 |
| 3 模式选择器转盘 | 9 黄色碳刷 LED 指示灯 |
| 4 主手柄 | 10 DeWALT 工具标签安装孔 |
| 5 工具夹持器 | 11 日期代码 |
| 6 锁定套管 | |

设计用途

您的电锤设计用于专业切削和凿切应用。

请勿在潮湿环境中或在易燃液体或气体存在的环境中使用本工具。此电锤是专业的电动工具。

请勿让儿童接触本工具。缺乏经验的操作员需要在监督下使用本工具。

- **儿童和体弱者。**在没有他人监督的情况下，儿童或体弱者不宜使用本产品。
- 本产品不适合体力、感官或智力不足以及缺乏经验、知识或技能的人员（包括儿童）使用，除非一旁有能为他们的安全负责的监督人员。不得在无人监管的情况下让儿童接触本产品。

有源振动控制 (AVC) 系统

为获得最佳的振动控制，请按**正确的手持方式**所述握住工具，并向其施加足够的压力，使手柄上的阻尼装置大致处于中间。

有源振动控制可中和来自锤子机制的回弹振动。降低手部和手臂振动，可以更舒适地在更长的时间内使用本工具，并延长装置的使用寿命。

锤钻只需要适量力度即可启动有源振动控制。过度用力并不会加快工具切削的速度，也不会启动有源振动控制。

DeWALT 工具标签就绪 (图 A)

可选配件

您的锤钻自带 DeWALT 工具标签安装孔 **10** 和用于安装 DeWALT 工具标签的紧固件。您需要使用一个 T15 钻头以安装该标签。DeWALT 工具标签专为使用 DeWALT Tool Connect™ 应用程序跟踪和定位专业电动工具、设备和机器而设计。为正确安装 DeWALT 工具标签，请参阅 DeWALT 工具标签手册。



电子变速器和冲击控制 (图 A)

电子变速器和冲击控制是精确凿切的最佳工具控制装置。

如需设置电子变速器和冲击控制旋钮 **7**，请将其转动至所需等级。号码越高，速度和冲击能量就越大。旋钮设置使得工具的使用更加灵活方便，而且适用于多个不同的应用程序。所需的设置取决于凿切材料的钻头尺寸和硬度。

- 在软质、易脆材料上凿切，或在需要最大限度降低破损时，将旋钮调整为低设置；
- 在硬质材料上进行破碎时，将旋钮调整为高设置。

维修 LED 指示灯 (图 A)

LED 功能	说明
 红灯 (闪烁)	检修 如果工具出现故障，或者电刷完全磨损，则红色维修 LED 指示灯 8 会亮起。
 黄灯 (持续亮起)	毛刷维修服务 黄色电刷磨损 LED 指示灯 9 在碳刷接近损坏时会亮起，表明工具需要在之后 8 个小时的使用中进行维修。

组装与调整

警告：为降低严重的人身伤害风险，在进行任何调整或取出/安装附件或配件之前，请关闭工具电源和断开工具电源连接。意外启动可能会导致人身伤害。

侧手柄 (图 B)

警告：为降低人身伤害风险，始终在正确安装侧手柄的情况下操作工具。否则，可能导致侧手柄在工具操作时滑动并随后失控。用双手握住工具以充分控制它。

侧手柄 **12** 夹紧至排档外壳，可 360° 旋转以方便右手或左手使用。

安装侧手柄组件 (图 B)

1. 通过逆时针转动用于安装侧手柄的螺钉 **13** 将侧手柄 **12** 开环 **14** 松开。
2. 将组件滑至工具前端，使其穿过钢环 **14**，穿过凿子固定器和套管放到轴环 **2** 上。
3. 将侧手柄组件旋转至所需位置。
4. 通过顺时针转紧用于安装侧手柄的螺钉 **13**，将侧手柄安装组件锁定到位，使组件不会旋转。

钻头与钻头夹持器

警告：灼伤危险。更换附件时请务必佩戴手套。工具和钻头上的可接触金属部件可能会在操作过程中变得非常热。少量破碎材料可能会导致双手受伤。

警告：不要尝试通过握住夹头前端和打开工具来拧紧或拧松凿子钻头（或任何其它附件）。这可能会导致夹头受损和人身伤害。

视所需应用而定，本充电式电镐可搭配使用不同的钻头。**请只使用锋利的钻头。**

插入和取出 SDS MAX 钻头 (图 C)

注：SDS 设备中使用的附件和附加装置必须在安装前进行润滑。

1. 向后拉锁定套管 **6** 然后插入钻头杆。清洁钻头杆。
2. 稍微转动钻头直到套管卡入到位。
3. 确保钻头正确锁定。
注：钻头需要移动几厘米进出工具固定器 **5** 以正确啮合。
4. 如果要取出钻头，请向后拉套管，然后将钻头拉出。

钻头位置调节

将模式选择器转至钻头调节图标（参阅**模式选择**），以将凿子转到所需位置。我们提供多个位置来设置凿子的角度。

注：找到所需位置后，稍微来回移动凿子，以确保凿子正确锁定。

操作

使用说明

警告：务必遵守安全指示和适用法规。

警告：为降低严重的人身伤害风险，在进行任何调整或取出/安装附件或配件之前，请关闭工具电源和断开工具电源连接。意外启动可能会导致人身伤害。

正确的手持方式 (图 D)

警告：为降低严重的人身伤害风险，请务必使用正确的手持方式，如图所示。

警告：为降低严重人身伤害的风险，请务必紧握工具以防止意外事件。

正确的手持方式要求一只手握住安装的侧手柄 **12**，另一只手则握住主手柄 **4**。

模式选择 (图 A)

警告: 在工具运行时切勿选择操作模式。工具必须先完全停下来后,才可激活模式选择器按钮,否则可能会损坏工具。

本工具配备模式选择器转盘 **3**,可用于选择适合所需操作的模式。

标识	模式	应用
	钻头调节	凿子钻头位置调节
	锤击/切削	轻型凿切、凿打和破碎

选择模式

• 旋转模式选择器转盘,使箭头指向对应于所需模式的符号。

注: 模式选择器转盘 **3** 上的箭头必须始终指向某模式符号。各符号之间没有可操作的位置。

标记凿子位置 (图 A)

可标记凿子并将它锁定在 18 个不同的位置中。

1. 旋转模式选择器开关 **3** 直到它指向 **0** 位置。
2. 将凿子旋转至所需位置。
3. 将模式选择器开关 **3** 设定为“锤击/切削”位置。
4. 扭转凿子,直到其锁定到位。

执行应用 (图 A、B)

警告: 为降低人身伤害风险,请务必确保牢固锚定或夹紧工件。

注: 工具的操作温度为 7°C 至 +40°C。在此温度范围外使用工具会降低工具的使用寿命。

1. 插入相应的凿子,然后用手旋转以使其锁定到位。请参阅 **钻头与钻头夹持器**。
2. 使用模式选择器转盘 **3**,选择切削模式。请参阅 **模式选择**。
3. 根据需要调整侧手柄 **12**。参阅 **安装侧手柄组件**。
4. 将凿子放在所需位置。
5. 按下翘板开关 **11**。
6. 要停止运转电锤,请松开翘板开关。

维护

您的电动工具设计精良,可以长期使用,仅需极少维护。要持续获得令人满意的工作效果,需要进行合适的工具维护和定期清洁。

警告: 为降低严重的人身伤害风险,在进行任何调整或取出/安装附件或配件之前,请关闭工具电源和断开工具电源连接。意外启动可能会导致人身伤害。



润滑

本电动工具无需另行润滑。



清洁

警告: 一旦看到通风口及其周围积聚了尘屑,请用干燥的空气将灰尘和尘屑从主机外壳内吹出。执行此过程时,需戴上经认可的护目装备和防尘面具。

警告: 请勿使用溶剂或其它刺激性化学制品来清洁工具的非金属部件。这些化学物质可能会削弱这些部位使用的材料。请用布蘸温和的肥皂水擦拭。切勿让任何液体渗入工具,切勿让工具的任何部件浸在液体中。

可选配件

警告: 除了 DeWALT 提供的附件之外,其他附件都未经此产品兼容性测试,若将此类附件与本工具一起使用将存在安全隐患。为降低人身伤害风险,本产品只可使用 DeWALT 推荐的附件。

有各种不同类型的 SDS MAX 凿子可供选购。SDS MAX 设备中使用的附件和附加装置必须定期进行润滑。

请向您的经销商咨询更多关于合适附件的信息。

保护环境



分类回收。由此符号标记的产品不得与普通家庭垃圾一起处理。

产品包含可恢复或回收的材料,从而降低对原材料的需求。请根据当地供给回收电子产品。如需获得更多信息,

请参看 www.2helpU.com。

制造商: 百得(苏州)科技有限公司

地址: 江苏省苏州工业园区苏虹中路 200 号出口加工区

产地: 江苏苏州

产品中有害物质的名称及含量

部件名称 Parts name	有害物质					
	铅 (Pb)	汞 (Hg)	镉 (Cd)	六价铬 (Cr(VI))	多溴联苯 (PBB)	多溴二苯醚 (PBDE)
马达组件	O	O	O	O	O	O
机壳组件	O	O	O	O	O	O
控制部件 (开关, PCB 等)	X	O	O	O	O	O
传动部件	X	O	O	O	O	O
电线组件	X	O	O	O	O	O
附件 (钻头/砂轮片等)	O	O	O	O	O	O

本表格依据 SJ/T 11364 的规定编制。

O: 标识该有害物质在该部位所有均质材料中的含量均在 GB/T 26572 规定的限量要求以下。

X: 标识该有害物质至少在该部位的某一均质材料中的含量超出 GB/T 26572 规定的限量要求。

备注: 本产品不必包含以上所述的所有部件。由于生产工艺和技术的不可替代性, 本产品中含有某些有害物质, 在环保使用期限内可以放心使用, 超过环保使用期限之后则应进入回收循环系统。

环保使用期限为“电子电气产品中含有的有害物质不会发生外泄或突变, 电子电气产品用户正常使用该电子电气产品不会对环境造成严重污染或对其人身、财产造成严重损害的期限”。



: 环保使用期限为 20 年。此环保使用期限不代表产品的安全使用期限和质量保证年限。

