

DEWALT®

D21110

English

4

简体中文

8

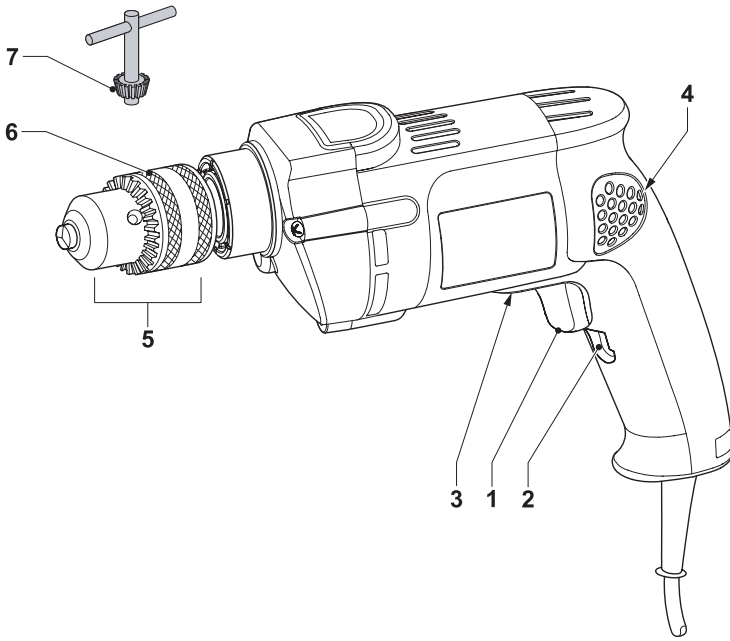

A

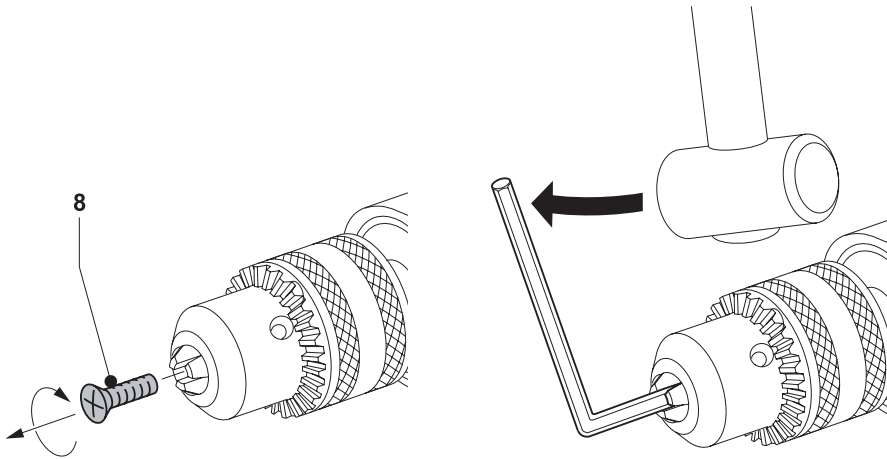

B

ROTARY DRILL D21110

Congratulations!

You have chosen a DeWALT Power Tool. Years of experience, thorough product development and innovation make DeWALT one of the most reliable partners for professional Power Tool users.

Technical data

	D21110	
Voltage	V	220
Power input -A9	W	600
No-load speed	min ⁻¹	0 - 2,600
Maximum drilling range in steel/wood	mm	13/25
Chuck spindle thread size	UNF	1/2" x 20
Collar diameter	mm	43
Maximum chuck capacity	mm	13
Weight	kg	1.8

Fuses:

220-240 V tools 10 Amperes, mains

The following symbols are used throughout this manual:



Denotes risk of personal injury, loss of life or damage to the tool in case of non-observance of the instructions in this manual.



Denotes risk of electric shock.

EC-Declaration of conformity



D21110

DeWALT declares that these Power Tools have been designed in compliance with: 98/37/EEC, 89/336/EEC, 73/23/EEC, EN 50144, EN 55014-2, EN 55014, EN 61000-3-2 & EN 61000-3-3.

For more information, please contact DeWALT at the address below, or refer to the back of the manual. Level of sound pressure according to 86/188/EEC & 98/37/EEC, measured according to EN 50144:

	D21110	
p_{dA} (sound pressure)	dB(A)*	98
L_{WA} (acoustic power)	dB(A)	111

* at the operator's ear



Take appropriate measures for the protection of hearing.

Weighted root mean square acceleration value according to EN 50144:

D21110	
	10.4 m/s ²

Director Engineering and Product Development
Horst Großmann

DeWALT, Richard-Klinger-Straße 11
D-65510, Idstein, Germany

General safety rules

Warning! Read all instructions. Failure to follow all instructions listed below may result in electric shock, fire and/or serious injury. The term “power tool” in all of the warnings listed below refers to your mains operated (corded) power tool or battery operated (cordless) power tool. SAVE THESE INSTRUCTIONS.

1 Work area

- a Keep work area clean and well lit.** Cluttered and dark areas invite accidents.
- b Do not operate power tools in explosive atmospheres, such as in the presence of flammable liquids, gases or dust.** Power tools create sparks which may ignite the dust or fumes.
- c Keep children and bystanders away while operating a power tool.** Distractions can cause you to lose control.

2 Electrical safety

- a Power tool plugs must match the outlet. Never modify the plug in any way. Do not use any adapter plugs with earthed (grounded) power tools.** Unmodified plugs and matching outlets will reduce risk of electric shock.
- b Avoid body contact with earthed or grounded surfaces such as pipes, radiators, ranges and refrigerators.** There is an increased risk of electric shock if your body is earthed or grounded.
- c Do not expose power tools to rain or wet conditions.** Water entering a power tool will increase the risk of electric shock.
- d Do not abuse the cord. Never use the cord for carrying, pulling or unplugging the power tool. Keep cord away from heat, oil, sharp edges or moving parts.** Damaged or entangled cords increase the risk of electric shock.
- e When operating a power tool outdoors, use an extension cord suitable for outdoor use.** Use of a cord suitable for outdoor use reduces the risk of electric shock.

3 Personal safety

- a Stay alert, watch what you are doing and use common sense when operating a power tool. Do not use a power tool while you are tired or under the influence of drugs, alcohol or**

medication. A moment of inattention while operating power tools may result in serious personal injury.

- b Use safety equipment. Always wear eye protection.** Safety equipment such as dust mask, non-skid safety shoes, hard hat, or hearing protection used for appropriate conditions will reduce personal injuries.
- c Avoid accidental starting. Ensure the switch is in the off position before plugging in.** Carrying power tools with your finger on the switch or plugging in power tools that have the switch on invites accidents.
- d Remove any adjusting key or wrench before turning the power tool on.** A wrench or a key left attached to a rotating part of the power tool may result in personal injury.
- e Do not overreach. Keep proper footing and balance at all times.** This enables better control of the power tool in unexpected situations.
- f Dress properly. Do not wear loose clothing or jewellery. Keep your hair, clothing and gloves away from moving parts.** Loose clothes, jewellery or long hair can be caught in moving parts.
- g If devices are provided for the connection of dust extraction and collection facilities, ensure these are connected and properly used.** Use of these devices can reduce dust related hazards.

4 Power tool use and care

- a Do not force the power tool. Use the correct power tool for your application.** The correct power tool will do the job better and safer at the rate for which it was designed.
- b Do not use the power tool if the switch does not turn it on and off.** Any power tool that cannot be controlled with the switch is dangerous and must be repaired.
- c Disconnect the plug from the power source before making any adjustments, changing accessories, or storing power tools.** Such preventive safety measures reduce the risk of starting the power tool accidentally.
- d Store idle power tools out of the reach of children and do not allow persons unfamiliar with the power tool or these instructions to operate the power tool.** Power tools are dangerous in the hands of untrained users.

- e **Maintain power tools. Check for misalignment or binding of moving parts, breakage of parts and any other condition that may affect the power tools operation. If damaged, have the power tool repaired before use.** Many accidents are caused by poorly maintained power tools.
- f **Keep cutting tools sharp and clean.** Properly maintained cutting tools with sharp cutting edges are less likely to bind and are easier to control.
- g **Use the power tool, accessories and tool bits etc., in accordance with these instructions and in the manner intended for the particular type of power tool, taking into account the working conditions and the work to be performed.** Use of the power tool for operations different from those intended could result in a hazardous situation.

5 Service

- a **Have your power tool serviced by a qualified repair person using only identical replacement parts.** This will ensure that the safety of the power tool is maintained.

Package contents

The package contains:

- 1 Percussion drill
- 1 Chuck key
- 1 Instruction manual

Check for damage to the tool, parts or accessories which may have occurred during transport.

Take the time to thoroughly read and understand this manual prior to operation.

Description (fig. A)

- 1 Variable speed switch
- 2 Lock-on button
- 3 Forward/reverse slider
- 4 Ventilation slots
- 5 Keyed chuck
- 6 Sleeve
- 7 Chuck key

Electrical safety

The electric motor has been designed for one voltage only. Always check that the power supply corresponds to the voltage on the rating plate.



Your DeWALT tool is double insulated in accordance with EN 50144; therefore no earth wire is required.

Using an extension cable

If an extension cable is required, use an approved extension cable suitable for the power input of this tool (see technical data). The minimum conductor size is 1.5 mm². When using a cable reel, always unwind the cable completely.

Also refer to the table below.

Conductor size (mm ²)	Cable rating (Amperes)					
0,75	6					
1,00	10					
1,50	15					
2,50	20					
4,00	25					
Cable length (m)						
	7,5	15	25	30	45	60
Voltage	Amperes	Cable rating (Amperes)				
220-240	0 - 2,0	6	6	6	6	6
	2,1 - 3,4	6	6	6	6	6
	3,5 - 5,0	6	6	6	6	15
	5,1 - 7,0	10	10	10	10	15
	7,1 - 12,0	15	15	15	15	20
	12,1 - 20,0	20	20	20	20	25

Assembly and adjustment



Prior to assembly and adjustment always unplug the tool.

Selecting the operating mode (fig. B)

The tool can be used in two operating modes:



Rotary drilling:
for steel, wood and plastics.

Select the required operating mode by rotating the mode selector (4) to the required position.

Inserting and removing a bit (fig. A)

Keyed chuck

Open the chuck by turning the sleeve (9) counterclockwise and insert the bit shank. Put the chuck key (10) into each hole in the side of the chuck and turn clockwise until tight. To remove the bit, proceed in reverse order.

Inserting and removing a bit (fig. A)**Keyed chuck**

- Open the chuck by turning the sleeve (6) counterclockwise and insert the bit shank.
- Put the chuck key (7) into each hole in the side of the chuck and turn clockwise until tight.
- To remove the bit, proceed in reverse order.

Forward/reverse slider (fig. A)

- To select forward or reverse rotation, use the forward/reverse-switch (3) (see arrow on tool).



Always wait until the motor has come to a complete standstill before changing the direction of rotation.

Chuck removal (fig. B)

- Open the chuck jaws as far as possible.
- Insert a screwdriver into the chuck and remove the chuck retaining screw (8) by turning clockwise.
- Tighten an Allen key into the chuck and strike it with a hammer as shown.

Instructions for use

- Always observe the safety instructions and applicable regulations.
- Be aware of the location of pipework and wiring.
- Apply only a gentle pressure to the tool. Excessive force does not speed up drilling but decreases tool performance and may shorten tool life.

Prior to operation:

- Insert the appropriate bit.
- Mark the spot where the hole is to be drilled.

Switching on and off (fig. A)

- To run the tool, press the variable speed switch (1). The pressure exerted on the variable speed switch determines the tool speed.

- If necessary, press the lock-on button (2) for continuous operation and release the switch. The lock-on button works only in full speed, forward rotation.
- To stop the tool, release the switch.
- To stop the tool in continuous operation, press the switch briefly and release it. Always switch off the tool when work is finished and before unplugging.

Screwdriving

- Select forward or reverse rotation.

Consult your dealer for further information on the appropriate accessories.

Maintenance

Your DEWALT Power Tool has been designed to operate over a long period of time with a minimum of maintenance. Continuous satisfactory operation depends upon proper tool care and regular cleaning.

**Lubrication**

Your power tool requires no additional lubrication.

**Cleaning**

Keep the ventilation slots clear and regularly clean the housing with a soft cloth.

**Unwanted tools and the environment**

Take your tool to an authorized DEWALT repair agent where it will be disposed of in an environmentally safe way.

D21110电钻

祝贺您!

您已选择了得伟电动工具。多年的行业经验、全面的产品开发和创新能力，使得得伟成为了电动工具使用者最可信赖的伙伴之一。

技术数据

		D21110
电压	V	220
输入功率 -A9	W	600
空载转速	min ⁻¹	0 - 2,600
钢材 / 木材		
最大钻孔直径	mm	13/25
夹头螺纹口尺寸	UNF	1/2" x 20
轴环直径	mm	43
夹头最大尺寸(直径)	mm	13
重量	kg	1.8
保险丝:		
220-240 伏特		10安培

本手册中普遍使用下列符号:



表示如违反本手册中的有关指示，将造成人身伤害、死亡或者工具损坏的危险。



表示电击危险。

符合欧洲委员会标准声明



D21110

得伟声明本手册提到的电动工具的设计完全符合下列各标准: 98/37/EEC 89/336/EEC 73/23/EEC EN 50144 EN 55014-2 EN 55014 EN 61000-3-2以及EN 61000-3-3

有关进一步的信息，请按下列地址联系得伟，或者参照本手册背后的指引。

按照EN 50144标准测定的符合86/188/EEC标准及98/37/EEC标准的声压级:

		D21110
L _{PA} (声压)	dB(A)*	98
L _{WA} (声功率)	dB(A)	111

* 操作员耳朵附近值。



请采取适当的措施保护听觉。

根据EN 50144标准测定的加速度加权均方根值:

D21110
10.4 m/s ²

工程和产品开发主管
Horst Großmann

DeWALT, Richard-Klinger-Straße 11
D-65510, Idstein, 德国

一般安全规则

警告！ 请仔细阅读本手册的全部指令。如未能遵守下列任何指令，则可能会导致电击、火灾和/或严重的人身伤害。下文所有警告中的“电动工具”一词指您的电网电源供电(有绳)电动工具、或电池驱动的(无绳)电动工具。

请妥善保管本手册，以备将来参考使用。

1 工作场地

- A) 保持工作场地清洁和明亮。混乱和黑暗的场地会引发事故。
- B) 不要在易爆环境，如有易燃液体、气体或粉尘的环境下操作电动工具。电动工具产生火花会点燃粉尘或气体。
- C) 让儿童和旁观者离开后操纵电动工具。分心会使你放松控制。

2 电器安全

- A) 电动工具插头必须与插座相配，绝不能以任何方式改装插头。需要接地的电动工具不能使用任何转换插头。未经改装的插头和相配的插座将减少触电危险。
- B) 避免人体接触接地表面，如管道、散热片和冰箱。如果你身体接地会增加触电危险。
- C) 不得将电动工具暴露在雨中或潮湿环境中。水进入电动工具将增加触电危险。
- D) 不得滥用电线，绝不能用电线搬运、拉动电动工具或拔出其插头。让电动工具远离热、油、锐边或运动部件。受损或缠绕的电线会增加触电危险。
- E) 当在户外使用电动工具时，使用适合户外使用的外接电线。适合户外使用的电线将减少触电危险。

3 人身安全

- A) 保持警觉，当操作电动工具时关注所从事的操作并保持清醒。切勿在有疲倦，药物、酒精或治疗反应下操作电动工具。在操作电动工具期间精力分散会导致严重人身伤害。

- B) 使用安全装置。始终佩戴护目镜。安全装置，诸如适当条件下的防尘面具、防滑安全鞋、安全帽、听力防护等装置能减少人身伤害。
- C) 避免突然启动。确保开关在插入插头时处于关闭位置。手指放在已接通电源的开关上或开关处于接通时插入插头可能会导致危险。
- D) 在电动工具接通之前，拿掉所有调节钥匙或扳手。遗留的电动工具旋转零件上的扳手或钥匙会导致人身伤害。
- E) 手不要伸得太长。时刻注意脚下和身体平衡。这样在意外情况下也能很好地控制电动工具。
- F) 着装适当。不要穿宽松衣或佩带饰品。让你的头发、衣服和袖子远离运动部件。宽松衣服、佩饰或长发可能会卷入运动部件。
- G) 如果提供了与排屑装置、集尘设备连接用的装置，则确保他们连接完好且使用得当。使用这些装置可减少碎屑引起的危险。

4 电动工具使用和注意事项

- A) 不要滥用电动工具，根据用途使用适当的电动工具。使用适当的设计额定值的电动工具会使你工作更有效、更安全。
- B) 如果开关不能接通或关闭工具电源，则不能使用该电动工具。不能用开关来控制的电动工具是危险的且必须进行修理。
- C) 在进行任何调节、更换附件或贮存电动工具之前，必须从电源上拔掉和/或将电池盒取下。这种防护性措施将减少电动工具突然启动的危险。
- D) 将闲置电动工具贮存在儿童所及范围之外，并且不要让不熟悉电动工具或对这些说明不了解的人操作电动工具。电动工具在未经训练的用戶手中是危险的。
- E) 保养电动工具。检查运动件的安装偏差或卡住、零件破损情况和影响电动工具运行的其他条件。如有损坏，电动工具必须在使用前修理好。许多事故由维护不良的电动工具引发。
- F) 保持切削刀具锋利和清洁。保养良好的有锋利切削刃的刀具不易卡住而且容易控制。

G) 按照使用说明书以及打算使用的电动工具的特殊类型要求的方式，考虑作业条件和进行的作业来使用电动工具、附件和工具的刀头等。将电动工具用作那些与要求不符的操作可能会导致危险情况。

5 维修

A) 将你的电动工具送交专业维修人员，必须使用同样的备件进行更换。这样将确保所维修的电动工具的安全性。

包装内容

包装内包括：

- 1 电钻一台
- 1 夹头钥匙一把
- 1 使用手册一本
- 1 质保卡一份
- 1 维修服务联系卡一份
- 1 分解图一份

- 检查工具、部件或配件是否有在运输过程中可能出现的损坏情况。
- 操作前通读并完全了解本手册的指示。

图 A 描述

- 1 电子无级调速开关
- 2 锁定按钮
- 3 正反转开关
- 4 通风口
- 5 钻夹头
- 6 套筒
- 7 夹头钥匙

电气安全

电机设计只能使用一种电压。每次使用均应检查电源与铭牌上的电压是否相符。



您的得伟工具已按照标准EN50144采用双重绝缘设计，因此无须连接地线。

使用延长电缆

如要使用延长电缆，应当使用经核准的适用于本工具输入功率的(见技术数据)延长电缆。最小应采用导体截面积为1.5平方毫米的电缆。使用电缆盘时，应切记将电缆完全展开。另外可参照下表。

导体截面积大小 (平方毫米)	电缆额定电流值 (安培)					
	7.5	15	25	30	45	60
0.75	6					
1.00	10					
1.50	15					
2.50	20					
4.00	25					
	电缆长度 (米)					
	7.5	15	25	30	45	60
电压 (伏)	电流 (安培)	电缆额定电流值 (安培)				
220-240	0 - 2.0	6	6	6	6	6
	2.1 - 3.4	6	6	6	6	6
	3.5 - 5.0	6	6	6	10	15
	5.1 - 7.0	10	10	10	10	15
	7.1 - 12.0	15	15	15	15	20
	12.1 - 20.0	20	20	20	20	25

装配与调整



装配和调整前，切记将工具电线拔下。



本工具可以用于电钻模式，该模式用于钢材、木材和塑料。

装卸钻头 (图A)

有匙夹头

- 逆时针方向旋转夹头(6)，并装入钻头柄。
- 将夹头钥匙(7)插入夹头侧面的孔中，并顺时针旋转直到旋紧。
- 如要取出钻头，按上述步骤反序操作。

正反转开关(图A)

要选择正或反旋转，请使用正反转开关(3)(如图)工具上的箭头所示。



切记要等到马达完全停止后，方可改变旋转方向。

夹头的拆卸 (图B)

- 将夹头按逆时针方向转到最大位置。
- 将螺丝刀伸入夹头，顺时针旋转，取出固定夹头的螺丝 (8)。

使用指引



- 务必遵守安全指引和适用之法规。
- 留意施工场地的管道系统和布线位置。
- 给工具施加适当的压力。过度用力并不能加快钻孔速度，反而会降低工具的工作表现，还可能缩短工具的使用寿命。

操作前:

- 装入适当的钻头。
- 在要钻孔的位置上做好标记。

打开与关闭开关 (图A)

- 要启动工具，按下调速开关 (1)。在调速开关上施加的压力大小，决定工具运行速度的快慢。
- 要停止工具运行，松开调速开关即可。
- 如有必要，按下锁定按钮 (2)，使工具持续工作。锁定按钮仅在正转状态下有效。
- 要让连续工作的工具停止运行，快速按下开关并释放之。切记在工作完成时和拔下插头前关闭工具。

拧螺丝

- 选择正反转。

请联系您的经销商，征询有关适当配件的进一步信息。

维护

您的得伟动力工具设计精良，可以长期运作，而只需极少的维护。要取得连续的令人满意的工作效果，需要您做合适的保养和定期的清洁。



润滑

您的动力工具不需要额外的润滑。



清洁

保持通风孔的清洁，并定期用软布清洁工具外壳。



废弃工具与环境

将您废弃的工具拿到得伟授权的维修点，他们会以对环境安全的方式处置您废弃的工具。

制造商: 百得(苏州)科技有限公司
地址: 苏州工业园区出口加工区

