



FIG.A

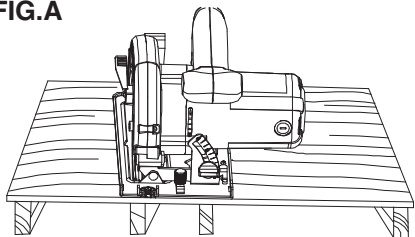

FIG.B

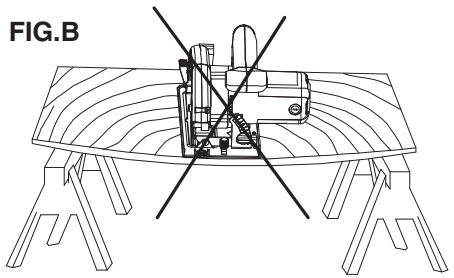

FIG.C

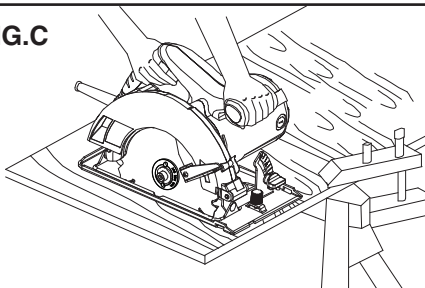

FIG.D

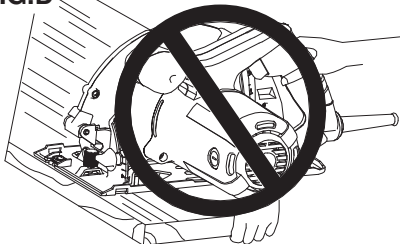

FIG.E

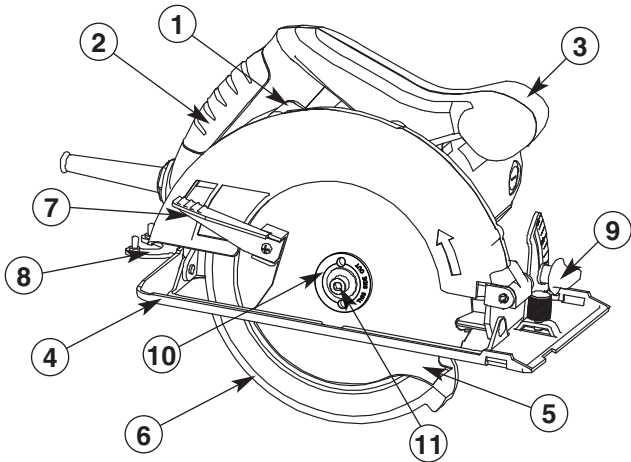

FIG.F

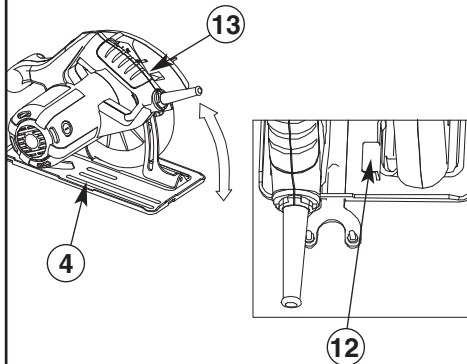
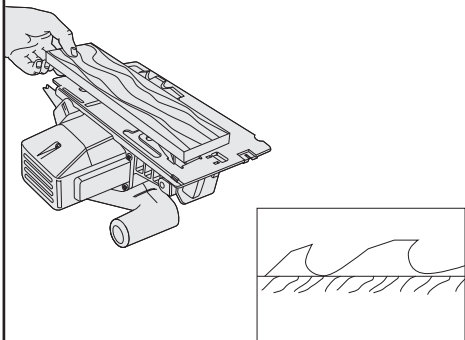
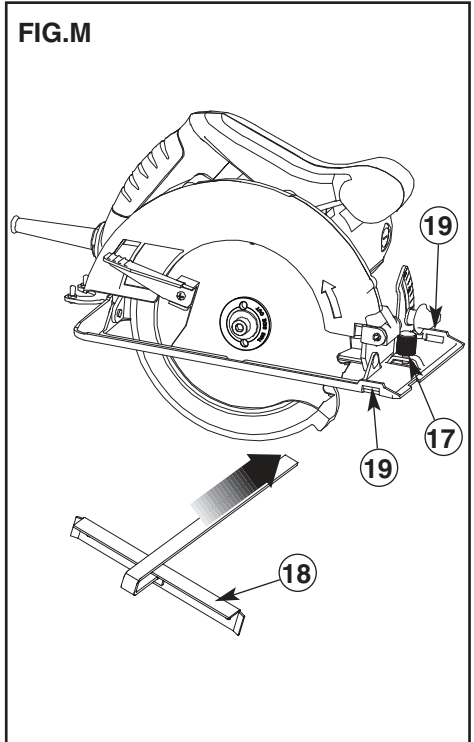
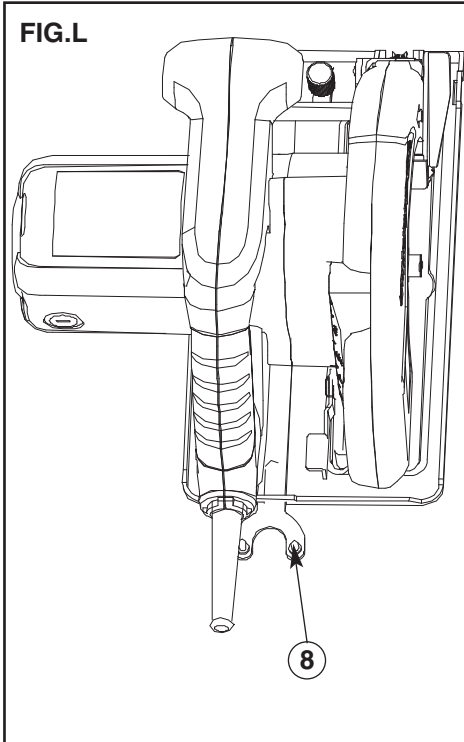
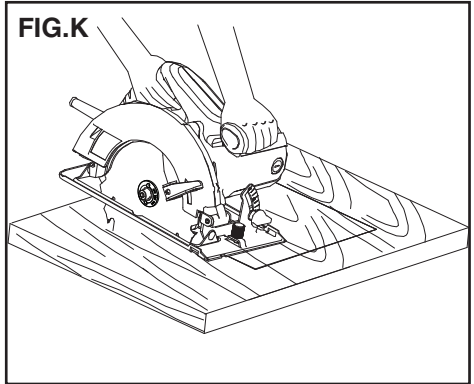
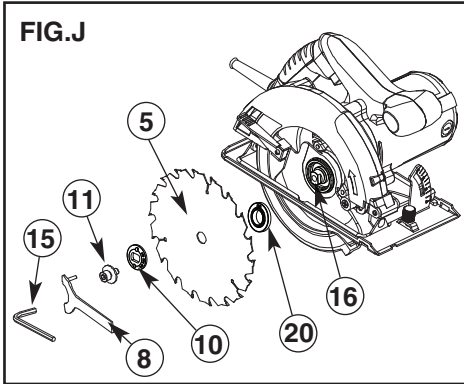
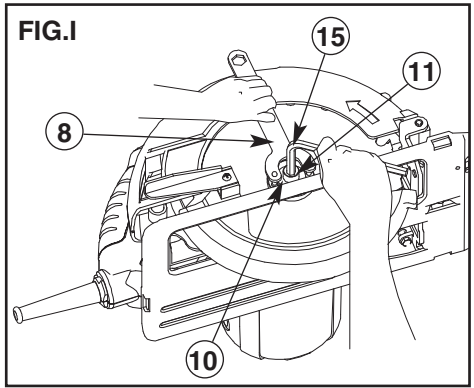
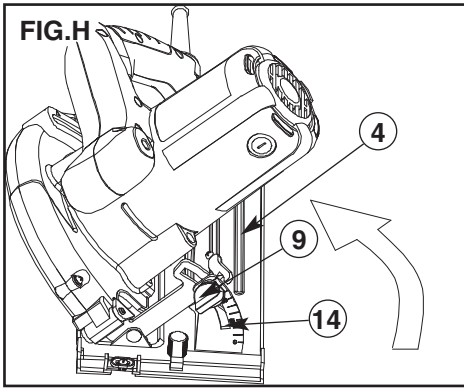

FIG.G





# CS1500

## 1500W Circular Saw

### TECHNICAL DATA

SPECIFICATION	CS1500	
VOLTAGE	V	230
INPUT	W	1500
NO-LOAD SPEED	/min	5500
MAX. BLADE DIAMETER	mm	185
MAX. CUTTING DEPTH	mm	62

### INTENDED USE

Your Black & Decker saw has been designed for sawing wood and wood products. This tool is intended for consumer use only.

### GENERAL SAFETY RULES

**Warning! Read and understand all instructions.**

Failure to follow all instructions listed below, may result in electric shock, fire and/or serious personal injury.

### SAFE THESE INSTRUCTIONS

#### SAFETY INSTRUCTIONS



General power tool safety warnings.

**Warning! Read all safety warnings and all instructions.** Failure to follow the warnings and instructions listed below may result in electric shock, fire and/or serious injury.

#### Save all warnings and instructions for future reference.

The term "power tool" in all of the warnings listed below refers to your mains operated (corded) power tool or battery operated (cordless) power tool.

#### 1. Work area

- Keep work area clean and well lit.** Cluttered and dark areas invite accidents.
- Do not operate power tools in explosive atmospheres, such as in the presence of flammable liquids, gases or dust.** Power tools create sparks which may ignite the dust or fumes.
- Keep children and bystanders away while operating a power tool.** Distractions can cause you to lose control.

#### 2. Electrical safety

- Power tool plugs must match the outlet. Never modify the plug in any way. Do not use any adapter plugs with earthed (grounded) power tools.** Unmodified plugs and matching outlets will reduce risk of electric shock.
- Avoid body contact with earthed or grounded surfaces such as pipes, radiators, ranges and refrigerators.** There is an increased risk of electric shock if your body is earthed or grounded.
- Do not expose power tools to rain or wet conditions.** Water entering a power tool will increase

the risk of electric shock.

- Do not abuse the cord. Never use the cord for carrying, pulling or unplugging the power tool. Keep cord away from heat, oil, sharp edges or moving parts.** Damaged or entangled cords increase the risk of electric shock.
  - When operating a power tool outdoors, use an extension cord suitable for outdoor use.** Use of a cord suitable for outdoor use reduces the risk of electric shock.
  - If operating a power tool in a damp location is unavoidable, use a residual current device (RCD) protected supply.** Use of an RCD reduces the risk of electric shock.
- #### 3. Personal safety
- Stay alert, watch what you are doing and use common sense when operating a power tool. Do not use a power tool while you are tired or under the influence of drugs, alcohol or medication.** A moment of inattention while operating power tools may result in serious personal injury.
  - Use safety equipment. Always wear eye protection.** Safety equipment such as dust mask, non-skid safety shoes, hard hat, or hearing protection used for appropriate conditions will reduce personal injuries.
  - Prevent unintentional starting. Ensure the switch is in the off-position before connecting to power source and/or battery pack, picking up or carrying the tool.** Carrying power tools with your finger on the switch or energising power tools that have the switch on invites accidents.
  - Remove any adjusting key or wrench before turning the power tool on.** A wrench or a key left attached to a rotating part of the power tool may result in personal injury.
  - Do not overreach. Keep proper footing and balance at all times.** This enables better control of the power tool in unexpected situations.
  - Dress properly. Do not wear loose clothing or jewellery. Keep your hair, clothing and gloves away from moving parts.** Loose clothes, jewellery or long hair can be caught in moving parts.
  - If devices are provided for the connection of dust extraction and collection facilities, ensure these are connected and properly used.** Use of these devices can reduce dust related hazards.
- #### 4. Power tool use and care
- Do not force the power tool. Use the correct power tool for your application.** The correct power tool will do the job better and safer at the rate for which it was designed.
  - Do not use the power tool if the switch does not turn it on and off.** Any power tool that cannot be controlled with the switch is dangerous and must be repaired.

- c. **Disconnect the plug from the power source and/or the battery pack from the power tool before making any adjustments, changing accessories, or storing power tools.** Such preventive safety measures reduce the risk of starting the power tool accidentally
- d. **Store idle power tools out of the reach of children and do not allow persons unfamiliar with the power tool or these instructions to operate the power tool.** Power tools are dangerous in the hands of untrained users.
- e. **Maintain power tools. Check for misalignment or binding of moving parts, breakage of parts and any other condition that may affect the power tools operation.** If damaged, have the power tool repaired before use. Many accidents are caused by poorly maintained power tools.
- f. **Keep cutting tools sharp and clean.** Properly maintained cutting tools with sharp cutting edges are less likely to bind and are easier to control.
- g. **Use the power tool, accessories and tool bits etc. in accordance with these instructions, taking into account the working conditions and the work to be performed.** Use of the power tool for operations different from those intended could result in a hazardous situation.

**5. Service**

- a. **Have your power tool serviced by a qualified repair person using only identical replacement parts.** This will ensure that the safety of the power tool is maintained.

**6. Electrical safety**



This appliance is double insulated therefore no earth wire is required. Always check that the power supply corresponds to the voltage on the rating plate.



**Warning!** If the power cord is damaged, it must be replaced by the manufacturer, authorized Black & Decker Service Center or an equally qualified person in order to avoid damage or injury. If the power cord is replaced by an equally qualified person, but not authorized by Black & Decker, the warranty will not be valid.

**7. Labels on tool**

The label on your tool may include the following symbols:

- V .....Volts
- A.....Amperes
- Hz .....Hertz
- W .....Watts
- min .....minutes
- ~ .....Alternating Current
- == .....Direct Current
- n<sub>0</sub> .....No-Load Speed

- .....Class II Construction
- .....Earthing Terminal
- .....Safe Alert Symbol
- .../min .....Revolutions or Reciprocation per
- .....Read instructions manual

- For tools intended to cut wood, instruction on correct use of the dust collection system.
- For tools intended to cut wood, instruction to wear a dust mask.
- Instruction to only use saw blades recommended.
- Instruction to always wear hearing protection.

**SAFETY INSTRUCTIONS FOR ALL SAWS  
CUTTING PROCEDURES**

- a. **⚠ DANGER: Keep hands away from cutting area and the blade. Keep your second hand on auxiliary handle, or motor housing.** If both hands are holding the saw, they cannot be cut by the blade.
- b. **Do not reach underneath the workpiece.** The guard cannot protect you from the blade below the workpiece.
- c. **Adjust the cutting depth to the thickness of the workpiece.** Less than a full tooth of the blade teeth should be visible below the workpiece.
- d. **Never hold piece being cut in your hands or across your leg.** Secure the workpiece to a stable platform. It is important to support the work properly to minimize body exposure, blade binding, or loss of control.
- e. **Hold power tool by insulated gripping surfaces when performing an operation where the cutting tool may contact hidden wiring or its own cord.** Contact with a "live" wire will also make exposed metal parts of the power tool "live" and shock the operator.
- f. **When ripping always use a rip fence or straight edge guide.** This improves the accuracy of cut and reduces the chance of blade binding.
- g. **Always use blades with correct size and shape (diamond versus round) of arbour holes.** Blades that do not match the mounting hardware of the saw will run eccentrically, causing loss of control.
- h. **Never use damaged or incorrect blade washers or bolt.** The blade washers and bolt were specially designed for your saw, for optimum performance and safety of operation.

**FURTHER SAFETY INSTRUCTIONS FOR ALL SAWS**

Causes and operator prevention of kickback:

- Kickback is a sudden reaction to a pinched, bound or misaligned saw blade, causing an uncontrolled saw to lift up and out of the workpiece toward the operator;
- When the blade is pinched or bound tightly by the kerf closing down, the blade stalls and the motor reaction drives the unit rapidly back toward the operator;

- If the blade becomes twisted or misaligned in the cut, the teeth at the back edge of the blade can dig into the top surface of the wood causing the blade to climb out of the kerf and jump back toward the operator.
  - Kickback is the result of saw misuse and/or incorrect operating procedures or conditions and can be avoided by taking proper precautions as given below.
- a. **Maintain a firm grip with both hands on the saw and position your arms to resist kickback forces.** Position your body to either side of the blade, but not in line with the blade. Kickback could cause the saw to jump backwards, but kickback forces can be controlled by the operator, if proper precautions are taken.

NOTE For circular saws with 185 mm or smaller diameter blades, the words "with both hands" may be omitted.

- b. **When blade is binding, or when interrupting a cut for any reason, release the trigger and hold the saw motionless in the material until the blade comes to a complete stop.** Never attempt to remove the saw from the work or pull the saw backward while the blade is in motion or kickback may occur. Investigate and take corrective actions to eliminate the cause of blade binding.
- c. **When restarting a saw in the workpiece, centre the saw blade in the kerf and check that saw teeth are not engaged into the material.** If saw blade is binding, it may walk up or kickback from the workpiece as the saw is restarted.
- d. **Support large panels to minimise the risk of blade pinching and KICKBACK.** Large panels tend to sag under their own weight. Supports must be placed under the panel on both sides, near the line of cut and near the edge of the panel.
- e. **Do not use dull or damaged blades.** Unsharpened or improperly set blades produce narrow kerf causing excessive friction, blade binding and kickback.
- f. **Blade depth and bevel adjusting locking levers must be tight and secure before making cut.** If blade adjustment shifts while cutting, it may cause binding and kickback.
- g. **Use extra caution when making a "plunge cut" into existing walls or other blind areas.** The protruding blade may cut objects that can cause kickback.

#### SAFETY INSTRUCTIONS FOR CIRCULAR SAW LOWER GUARD FUNCTION

- a. **Check lower guard for proper closing before each use. Do not operate the saw if lower guard does not move freely and close instantly. Never clamp or tie the lower guard into the open position.** If saw is accidentally dropped, lower guard may be bent. Raise the lower guard with the retracting handle and make sure it moves freely and does not touch the blade or any other part, in all angles and

depths of cut.

- b. **Check the operation of the lower guard spring. If the guard and the spring are not operating properly, they must be serviced before use.** Lower guard may operate sluggishly due to damaged parts, gummy deposits, or a build-up of debris.
- c. **Lower guard may be retracted manually only for special cuts such as "plunge cuts" and "compound cuts."** Raise lower guard by retracting handle and as soon as blade enters the material, the lower guard must be released. For all other sawing, the lower guard should operate automatically.
- d. **Always observe that the lower guard is covering the blade before placing saw down on bench or floor.** An unprotected, coasting blade will cause the saw to walk backwards, cutting whatever is in its path. Be aware of the time it takes for the blade to stop after switch is released.

#### SAFETY INSTRUCTIONS FOR CIRCULAR SAW

- a. **Check guard for proper closing before each use. Do not operate the saw if guard does not move freely and enclose the blade instantly.** Never clamp or tie the guard with the blade exposed. If saw is accidentally dropped, guard may be bent. Check to make sure that guard moves freely and does not touch the blade or any other part, in all angles and depths of cut.
- b. **Check the operation and condition of the guard return spring. If the guard and the spring are not operating properly, they must be serviced before use.** Guard may operate sluggishly due to damaged parts, gummy deposits, or a build-up of debris.
- c. **Assure that the guide plate of the saw will not shift while performing the "plunge cut" when the blade bevel setting is not at 90°.** Blade shifting sideways will cause binding and likely kick back.
- d. **Always observe that the guard is covering the blade before placing saw down on bench or floor.** An unprotected, coasting blade will cause the saw to walk backwards, cutting whatever is in its path. Be aware of the time it takes for the blade to stop after switch is released.

#### SAFETY GUIDELINES/DEFINITIONS

It is important for you to read and understand this manual. The information it contains relates to protecting **Your Safety and Preventing Problems.** The symbols below are used to help you recognize this information.

 **Danger!** Indicates an imminently hazardous situation which, if not avoided, will result in death or serious injury.

 **Warning!** Indicates a potentially hazardous situation which, if not avoided, could result in death or serious injury.

 **Caution!** Indicates a potentially hazardous

situation which, if not avoided, may result in minor or moderate injury.

**⚠ Caution!** Used without the safety alert symbol indicates potentially hazardous situation which, if not avoided, may result in property damage.

#### ADDITIONAL SAFETY RULES FOR CIRCULAR SAW

**⚠ Warning!** Use of this tool can generate and/or disburse dust, which may cause serious and permanent respiratory or other injury. Always use NIOSH/OSHA approved respiratory protection appropriate for the dust exposure. Direct particles away from face and body.

**⚠ Caution!** Wear appropriate hearing protection during use. Under some conditions and duration of use, noise from this product may contribute to hearing loss.

- **Snagging the lower guard on a surface below the material being cut can momentarily reduce operatol control.** The saw can lift partially out of the cut increasing the chance of blade twist. Ensure there is sufficient clearance under the workpiece.
- **When necessary to raise lower guard manually, use the retracting lever.**
- **Keep the Blades Clean and Sharp.** Sharp blades minimize stalling and kickback. The use of dull and/or dirty blades can increase the saw loading causing the operator to push harder which promotes twisting.

**⚠ Caution! Laceration Hazard. Keep hands away from cutting areas.** Keep hands away from blades. Never place hands in front of or behind the path of the blade while cutting. Do not reach underneath work while blade is rotating. Do not attempt to remove cut material when blade is moving.

- **Support large panels.** Large panels must be supported as shown (Fig. A) in this manual to minimize the risk of blade pinching and kickback. Material supported only at the ends (Fig. B) will lead to blade pinching. When cutting operation requires the resting of the saw on the workpiece, the saw shall be rested on the larger portion and the smaller piece cut off.
- **Use only correct blades and blade assembly components when mounting blades.** Do not use blades with incorrect size holes. Never use defective or incorrect blade washers or bolts. Follow blade assembly procedures.
- **Adjustments. Before cutting be sure depth and bevel adjustments are tight.**
- **Support and secure the work properly.** Insure that the material to be cut is clamped (Fig. C) and solidly supported and balanced on a strong, stable and level work surface. Support the work so that the wide portion of the saw shoe is on the portion of the material that doesn't fall after the cut is made. Never hold cut off piece by hand (Fig. D). KICKBACK from blade pinch can result. Keep both hands on saw at all

times.

- **Stay alert and exercise control. Keep body positioned to one side of blade.** Always maintain a firm grip and control of saw with both hands. Do not change hand grip or body position while saw is running. Take precaution to avoid injury from cut off pieces and other falling material during operation.

**⚠ Danger!** Release switch immediately if blade binds or saw stalls.

#### FEATURES (Fig. E)

1. On/Off Switch
  2. Main Handle
  3. Secondary Handle
  4. Shoe
  5. Saw Blade
  6. Saw Blade Guard
  7. Blade Guard Retracting Lever
  8. Saw Blade Spanner Wrench
  9. Bevel Adjustment Knob
  10. Outer Washer
  11. Blade Retaining Screw
- Saw Blade Hex Wrench (Shown on Fig. I (15))  
Rip Fence (Shown on Fig. M (18))  
Inner Flange (Shown on Fig. J (20))

#### ASSEMBLY/ADJUSTMENT SET-UP

**⚠ Warning!** Always unplug saw from power supply before any of the following operations.

#### Adjusting the Depth of Cut (Fig. F and G)

The depth of cut should be set according to the thickness of the workpiece.

- Loosen the lever (12) to unlock the saw shoe.
- Move the saw shoe (4) into the desired position. The corresponding depth of cut can be read from the scale (13).
- Tighten the lever to lock the saw shoe in place.
- Set depth adjustment of saw such that one tooth of the blade projects below the workpiece as shown in Fig. G.

#### Adjusting the Bevel Angle (Fig. H)

This tool can be set to bevel angles between 0° and 45°

- Loosen the locking knob (9) to unlock the saw shoe.
- Move the saw shoe (4) into the desired position. The corresponding bevel angle can be read from the scale (14).
- Tighten the locking knob to lock the saw shoe in place.

#### Attaching the Blade (Fig. I and J)

- To prevent spindle rotation engage the protrusions of the spanner wrench (8) into the holes in the outer washer (10) as shown in Fig. I.
- Loosen and remove the blade retaining screw (11) by turning the hex wrench (15) counter- clockwise.
- Remove the outer washer.

- Check and re-assembly inner flange (20) on spindle (16). Insure the correct side of inner flange (20) faces outward and match saw blade.
- Place the saw blade (5) onto the inner flange (20), making sure that the arrow on the blade points in the same direction as the arrow on the tool.
- Fit the outer washer (10) on the spindle.
- Insert the blade retaining screw (11) into the hole in the spindle.
- Prevent spindle rotation by engaging the spanne wrench into the holes of the outer washer.
- Securely tighten the blade retaining screw by holding the spanner wrench and turning hex wrench clockwise to tighten the blade retaining screw.
- ⚠ **Warning!** Inner flange (20) respectively marked with “19” and “20”, match the saw blade (5) with 19mm or 20mm diameter arbor.

### Removing the Blade

- To prevent spindle rotation, engage the protrusions of the spanner wrench (8) into the holes in the outer washer (10).
- Loosen and remove the blade retaining screw (11) by turning it counterclockwise using the hex wrench (15).
- Remove the outer washer (10).
- Remove the saw blade (5).
- ⚠ **Warning!** To reduce the risk of serious personal injury, read, understand and follow all important safety warnings and instructions prior to using tool.

### GENERAL CUTS

#### Guard Against Kickback

With unit unplugged, follow all assembly, adjustment and set up instructions. Make sure lower guard operates. Select the proper blade for the material to be cut.

- Measure and mark work for cutting.
- Support and secure work properly (See Safety Rules and Instructions).
- Use appropriate and required safety equipment (See Safety Rules).
- Secure and maintain work area (See Safety Rules).
- With plug inserted and guard closed, make sure switch turns saw on and off.

⚠ **Warning!** It is important to support the work properly and to hold the saw firmly to prevent loss of control which could cause personal injury. Fig. C illustrates recommended hand position.

### OPERATION

#### Switch

- To operate the tool, depress the trigger switch (1). The tool will continue to run as long as the trigger is depressed.
- To turn the tool off, release the trigger switch (1). There is no provision for locking the tool on, and the switch should never be locked on by any other means.

### Sawing

⚠ **Warning!** To reduce the risk of serious personal injury, always hold the tool with both hands.

- Let the blade run freely for a few seconds before starting the cut.
- Apply only a gentle pressure to the tool while performing the cut.
- Work with the shoe pressed against the workpiece.

### HINTS FOR OPTIMUM USE

- As some splintering along the line of cut on the top side of the workpiece cannot be avoided, cut on the side where splintering is acceptable.
- Where splintering is to be minimized, e.g. when cutting laminates, clamp a piece of plywood onto the top of the workpiece.

### Pocket Cutting (Fig. K)

**Pocket cutting is used to cut a hole in a piece of material without cutting from the side.**

- Measure and mark work.
- Tilt saw forward and rest front of the shoe on material to be cut. Align so that cut will begin at the back of the drawn rectangle shown in Fig. K.
- Using the retracting lever, retract blade guard to an upward position, with the blade just clearing the material, start motor and gradually lower the saw into the material.

⚠ **Warning!** As blade starts cutting the material, release the retracting lever immediately.

- Never tie the blade guard in a raised position.
- When the shoe rests flat on the material being cut, complete the cut in forward direction.
- Allow the blade to come to a complete stop before lifting saw from material.
- When starting each new cut, repeat the above steps.

### Wrench Storage (Fig. L)

The spanner wrench (8) can be stored on the saw shoe as shown in Fig. L.

### Attaching and Removing the Rip Fence (Fig. M)

The rip fence is used to saw in a straight line parallel to the edge of the working piece.

#### Attaching

- Loosen the locking knob (17).
- Insert the rip fence (18) through the openings (19).
- Slide the rip fence into the desired position.
- Tighten the locking knob.

#### Removing

- Loosen the locking knob.
- Pull the rip fence out of the tool. Note: If you do not have a proper fitting fence, use a straight edge guide in contact with the edge of the shoe to improve accuracy of cut and reduce the possibility of binding



and kickback.

### Accessories

The performance of your tool depends on the accessory used. Black & Decker accessories are engineered to high quality standards and designed to enhance the performance of your tool. By using these accessories you will get the very best from your tool.

**⚠ Warning!** The use of any accessory not recommended for use with this tool could be hazardous. Use only 185mm blades with 19mm or 20mm diameter arbor. Not to use any abrasive wheels.

### MAINTENANCE

Your tool has been designed to operate over a long period of time with a minimum of maintenance. Continuous satisfactory operation depends upon proper tool care and regular cleaning.

**⚠ Warning!** Before performing any maintenance, switch off and unplug the tool.

- Regularly clean the ventilation slots in your tool using a soft brush or dry cloth.
- Regularly clean the motor housing using a damp cloth. Do not use any abrasive or solvent-based cleaner.

**⚠ Important!** To assure product Safety and Reliability, repairs, maintenance and adjustment (other than those listed in this manual) should be performed by authorized service centers or other qualified service personnel, always using identical replacement parts.

### LUBRICATION

Black & Decker tools are properly lubricated at the factory and are ready for use.

### PROTECTING THE ENVIRONMENT



Separate collection. This product must not be disposed of with normal household waste.

Should you find one day that your Black & Decker product needs replacement, or if it is of no further use to you, do not dispose of it with household waste. Make this product available for separate collection.



Separate collection of used products and packaging allows materials to be recycled and used again. Re-use of recycled materials helps prevent environmental pollution and reduces the demand for raw materials.

Local regulations may provide for separate collection of electrical products from the household, at municipal waste sites or by the retailer when you purchase a new product.

### Service Information

Black & Decker offers a full network of company-owned and authorized service locations throughout Asia. All Black & Decker Service Centers are staffed with trained personnel to provide customers with efficient and reliable power tool service. Whether you need technical advice, repair, or genuine factory replacement parts, contact the Black & Decker location nearest to you.

### Notes

- Black & Decker's policy is one of continuous improvement to our products and, as such, we reserve the right to change product specifications without prior notice.
- Standard equipment and accessories may vary by country.
- Product specifications may differ by country.
- Complete product range may not be available in all countries. Contact your local Black & Decker dealers for range availability.