

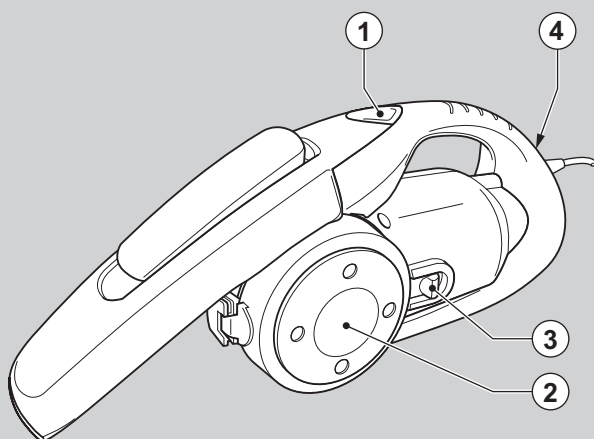

BLACK & DECKER®

www.blackanddecker.co.uk



UK

Ireland

Australia

New Zealand

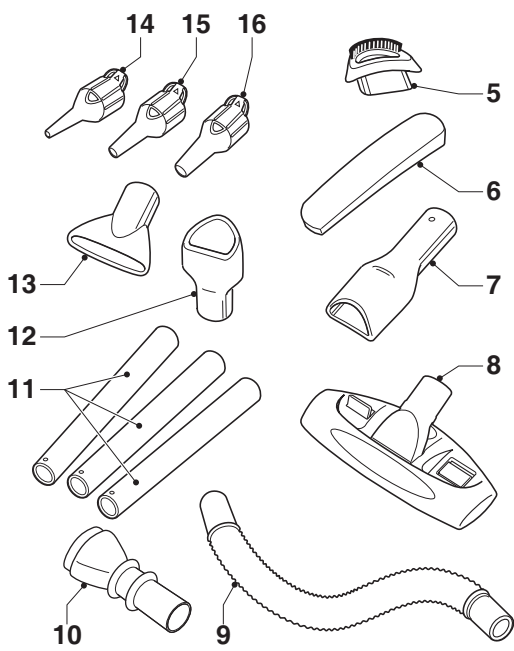

A

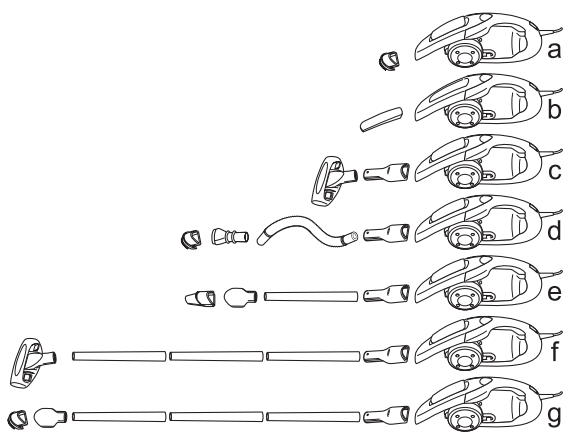

B

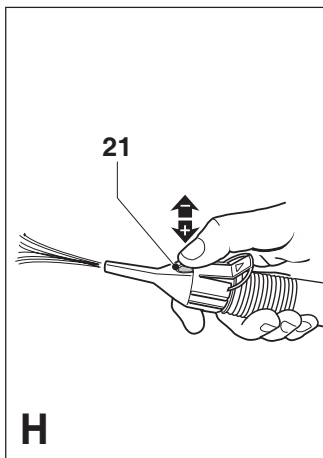
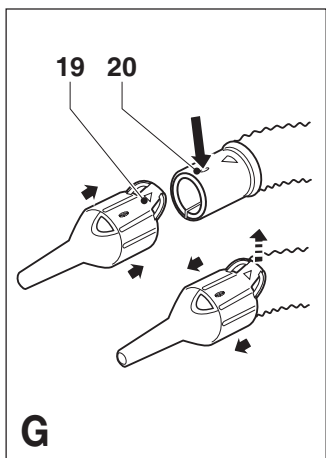
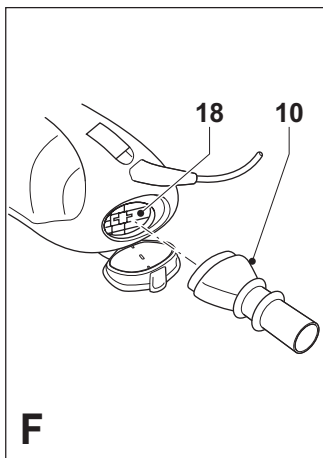
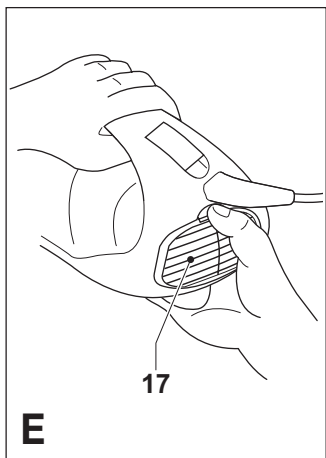
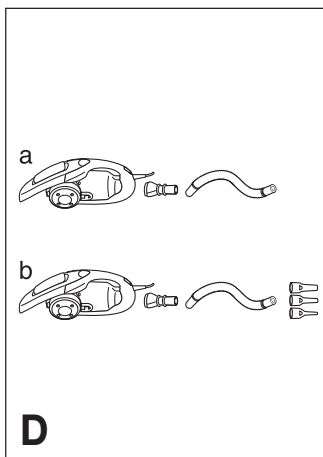
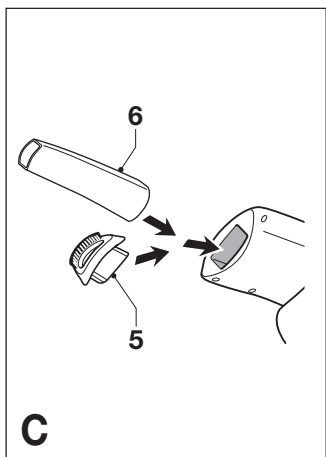

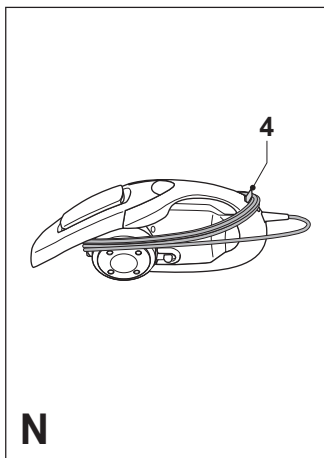
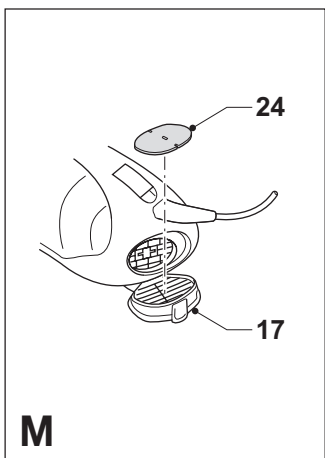
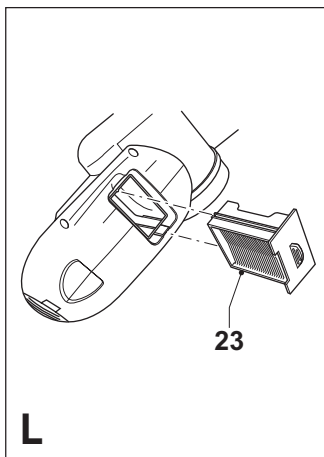
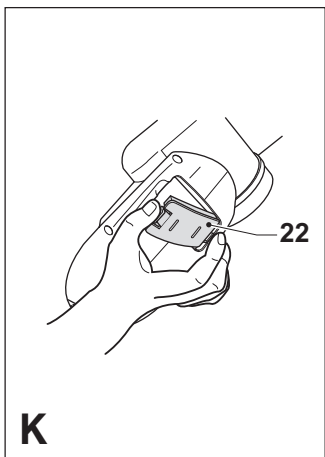
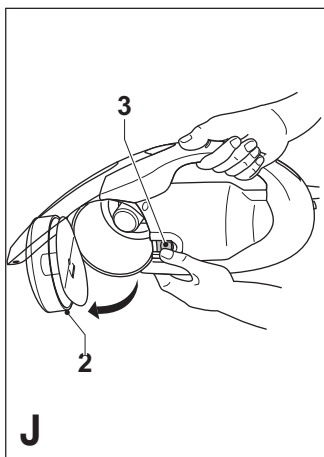
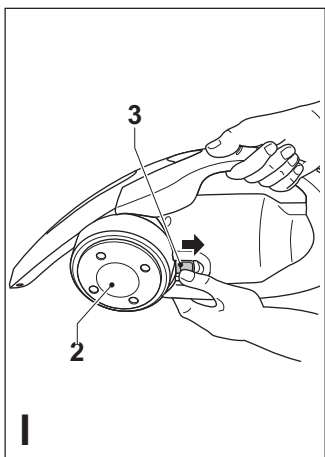

Intended use

Your Black & Decker Dustbuster® mini vac has been designed for light dry vacuum cleaning, as well as for light blowing and inflating purposes. This product is intended for household use only.

Safety instructions

- ◆ **Warning!** When using mains-powered appliances, basic safety precautions, including the following, should always be followed to reduce the risk of fire, electric shock, personal injury and material damage.
- ◆ Read all of this manual carefully before using the appliance.
- ◆ The intended use is described in this manual. The use of any accessory or attachment or the performance of any operation with this appliance other than those recommended in this instruction manual may present a risk of personal injury.
- ◆ Retain this manual for future reference.

Using your appliance

- ◆ Do not use the appliance to pick up liquids or any materials that could catch fire.
- ◆ Do not use the appliance to pick up sharp objects that could damage the filter or other parts.
- ◆ Do not use the appliance near water.
- ◆ Do not immerse the appliance in water.
- ◆ Keep the motor draught away from your eyes and face.
- ◆ Do not use the appliance outdoors.
- ◆ Keep children and animals at a safe distance when using this appliance.
- ◆ Do not leave the appliance unattended while it is connected to the power supply.
- ◆ Never pull the power supply cord to disconnect the plug from the socket. Keep the cord away from heat, oil and sharp edges.
- ◆ When using the appliance for blowing or inflating purposes:
 - Wear eye protection.

- Keep the air intake free from obstructions to prevent the motor from overheating.
- Do not point the air outlet at yourself, bystanders or animals.
- Do not exceed the recommended pressure of the item to be inflated.

After use

- ◆ Unplug the appliance before cleaning.
- ◆ When not in use, the appliance should be stored in a dry place. Children should not have access to stored appliances.

Inspection and repairs

- ◆ Before use, check the appliance for damaged or defective parts. Check for breakage of parts, damage to switches and any other conditions that may affect its operation.
- ◆ Do not use the appliance if any part is damaged or defective.
- ◆ Have any damaged or defective parts repaired or replaced by an authorised repair agent.
- ◆ Regularly check the power supply cord for damage. If the supply cord is damaged, it must be replaced by the manufacturer or an authorised Black & Decker Service Centre in order to avoid a hazard.
- ◆ Never attempt to remove or replace any parts other than those specified in this manual.

Electrical safety

- ◆ Before use, check that the mains voltage corresponds to the voltage on the rating plate.
- ◆ Do not use the appliance to vacuum any electrical appliances while they are plugged in.



This tool is double insulated; therefore no earth wire is required.

Features

1. On/off switch
2. Container door
3. Release button for container door
4. Power cord retainer

Fig. A

5. Hard brush
6. Crevice tool
7. Rigid adaptor
8. Floor head
9. Hose
10. Blow adaptor
11. Tubes
12. Tool adaptor
13. Blow diffuser
14. Small inflator adaptor
15. Medium inflator adaptor
16. Large inflator adaptor

Assembly

Warning! Make sure that the appliance is switched off and unplugged.

Fitting the accessories for vacuuming (fig. B & C)

The accessories provided can be used in various combinations, depending on the task (fig. B):

- a. General vacuuming / dusting
- b. Vacuuming in confined spaces
- c. Vacuuming stairs
- d. Vacuuming upholstery
- e. Vacuuming in corners
- f. Vacuuming carpeted floors
- g. Vacuuming hard floors

The hard brush (5) and the crevice tool (6) are stored in the appliance. To fit an accessory, proceed as follows (fig. C):

- ◆ Take the accessories from the appliance.
- ◆ Insert the appropriate accessory into the front of the appliance.

Fitting the accessories for blowing and inflating (fig. D - G)

The accessories provided can be used in various combinations, depending on the task (fig. D):

- a. Blowing
- b. Inflating

To fit an accessory, proceed as follows (fig. E & F):

- ◆ Open the exhaust filter cover (17).
- ◆ Insert the blow adaptor (10) into the opening (18). Make sure the adaptor fits snug against the rear of the appliance.
- ◆ Fit the hose (9) to the adaptor.
- ◆ Insert the appropriate accessory into the hose.

To fit an inflator adaptor to the hose, proceed as follows (fig. G):

- ◆ Align the tab (19) on the adaptor with the hole (20) in the hose end.
- ◆ Push the adaptor on the hose until it clicks into place.
- ◆ To remove the adaptor, lift up the tab and pull the adaptor off the hose.

Use

Warning! Before connecting to the power supply, make sure that the appliance is switched off.

Warning! Never use the appliance without the filters. Optimum dust collection will only be achieved with clean filters and an empty container.

Switching on and off (fig. A)

- ◆ To switch the tool on, press the on/off switch (1).
- ◆ To switch the tool off, press the on/off switch again.

Warning! Make sure the accessories are securely attached before switching on. Keep a firm grip on the appliance, and especially the hose, when switching on and during use.

Using the inflator adaptors (fig. H)

- ◆ Choose the appropriate adaptor for the item to be inflated.
- ◆ During inflation, the airflow can be adjusted by covering the hole (21) with your thumb.
- ◆ Do not over-inflate or exceed the recommended pressure of the item to be inflated.

Warning! The hole in the inflator adaptor acts as a relief valve to prevent over-inflating. Do not permanently cover the hole.

Resetting the motor thermal safeguard

The motor of the appliance is fitted with a thermal safeguard. This device automatically switches the appliance off in case of overheating. If this occurs, proceed as follows:

- ◆ Switch the appliance off and remove the plug from the wall socket.
- ◆ Allow the unit to cool. When the unit has cooled down, check and clean the filters.
- ◆ Re-insert the plug in the wall socket and switch the appliance on.

Emptying the container (fig. I & J)

When the container is full it should be emptied. Always empty the container into a waste bin outdoors.

- ◆ Slide the container release button (3) towards the back of the appliance to release the container door (2).
- ◆ Open the container door.
- ◆ Empty the container as necessary.
- ◆ Close the container door. Make sure the container door clicks into place.

Cleaning, maintenance and storage

Warning! Before cleaning and maintenance, switch the appliance off and unplug it.

- ◆ From time to time wipe the appliance with a damp cloth. Do not use any abrasive or solvent-based cleaner. Do not immerse the appliance in water.

Cleaning the motor filter (fig. K & L)

The filter is re-usable and should be cleaned regularly.

- ◆ Remove the lid (22).
- ◆ Take the filter (23) out of the appliance.
- ◆ Shake off excess dust by tapping the filter into a dustbin.

- ◆ Refit the filter (23) into the appliance.
- ◆ Refit the lid (22). Make sure the lid (22) clicks into place.

Cleaning the exhaust filter (fig. M)

The filter is re-usable and should be cleaned regularly.

- ◆ Open the cover (17).
- ◆ Pull the filter (24) from the retaining pin.
- ◆ Wash the filter in warm, soapy water.
- ◆ Make sure the filter is completely dry.
- ◆ Refit the filter (24).
- ◆ Close the cover.

Replacing the filters

The filters must be replaced when showing signs of wear or damage.

Replacement filters are available from your Black & Decker dealer.

- ◆ Remove the old filters as described above.
- ◆ Fit the new filters as described above.

Storing the appliance (fig. N)

- ◆ Flip up the power cord retainer (4).
- ◆ Wind the cord around the container and the retainer as shown.

Mains plug replacement (U.K. & Ireland only)

If a new mains plug needs to be fitted:

- ◆ Safely dispose of the old plug.
- ◆ Connect the brown lead to the live terminal in the new plug.
- ◆ Connect the blue lead to the neutral terminal.

Warning! No connection is to be made to the earth terminal. Follow the fitting instructions supplied with good quality plugs. Recommended fuse: 5 A.

Protecting the environment



Separate collection.
This product must not be disposed of with normal household waste.

Should you find one day that your Black & Decker product needs replacement, or if it is of no further use to you, do not dispose of it with household waste. Make this product available for separate collection.



Separate collection of used products and packaging allows materials to be recycled and used again. Re-use of recycled materials helps prevent environmental pollution and reduces the demand for raw materials.

Local regulations may provide for separate collection of electrical products from the household, at municipal waste sites or by the retailer when you purchase a new product.

Black & Decker provides a facility for the collection and recycling of Black & Decker products once they have reached the end of their working life. To take advantage of this service please return your product to any authorised repair agent who will collect them on our behalf.

You can check the location of your nearest authorised repair agent by contacting your local Black & Decker office at the address indicated in this manual. Alternatively, a list of authorised Black & Decker repair agents and full details of our after-sales service and contacts are available on the Internet at: **www.2helpU.com**

Technical data

	VH900	
Voltage	V _{AC}	230
Power input	W	900
Weight	kg	2.3

EC declaration of conformity

VH900

Black & Decker declares that these products conform to:
89/336/EEC, 73/23/EEC, EN 55014,
EN 60335, EN 61000

A handwritten signature in black ink that reads "K. Hewitt".

Kevin Hewitt

Director of Consumer Engineering
Spennymoor, County Durham DL16 6JG,
United Kingdom
1-5-2005

Guarantee

Black & Decker is confident of the quality of its products and offers an outstanding guarantee. This guarantee statement is in addition to and in no way prejudices your statutory rights. The guarantee is valid within the territories of the Member States of the European Union and the European Free Trade Area.

If a Black & Decker product becomes defective due to faulty materials, workmanship or lack of conformity, within 24 months from the date of purchase, Black & Decker guarantees to replace defective parts, repair products subjected to fair wear and tear or replace such products to ensure minimum inconvenience to the customer unless:

- ◆ The product has been used for trade, professional or hire purposes;
- ◆ The product has been subjected to misuse or neglect;
- ◆ The product has sustained damage through foreign objects, substances or accidents;
- ◆ Repairs have been attempted by persons other than authorised repair agents or Black & Decker service staff.

To claim on the guarantee, you will need to submit proof of purchase to the seller or an authorised repair agent. You can check the location of your nearest authorised repair agent by contacting your local Black & Decker office at the address indicated in this manual.

Alternatively, a list of authorised Black & Decker repair agents and full details of our after-sales service and contacts are available on the Internet at:

www.2helpU.com

Please visit our website

www.blackanddecker.co.uk to register your new Black & Decker product and to be kept up to date on new products and special offers. Further information on the Black & Decker brand and our range of products is available at **www.blackanddecker.co.uk**

Australia

Black & Decker (Australia) Pty. Ltd. Tel. 03-8720 5100
20 Fletcher Road, Mooroolbark,
Victoria, 3138 Fax 03-9727 594065

New Zealand

Black & Decker Tel. 09 579 7600
81 Hugo Johnston Drive Fax 09 579 8200
Penrose, Auckland, New Zealand

United Kingdom

Black & Decker Tel. 01753 511234
210 Bath Road Fax 01753 551155
Slough, Berkshire SL1 3YD Helpline 01753 574277