

FSM1610 TYPE1
FSM1620 TYPE1

English
简体中文

4
10

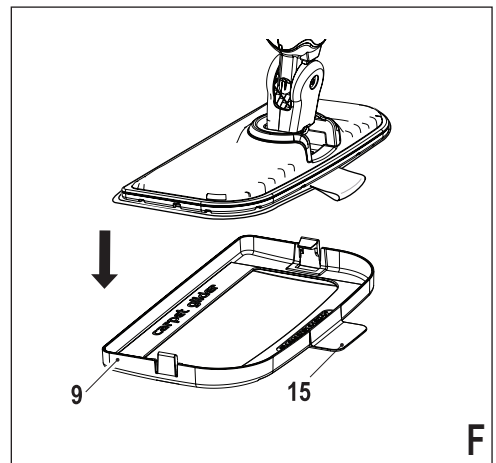

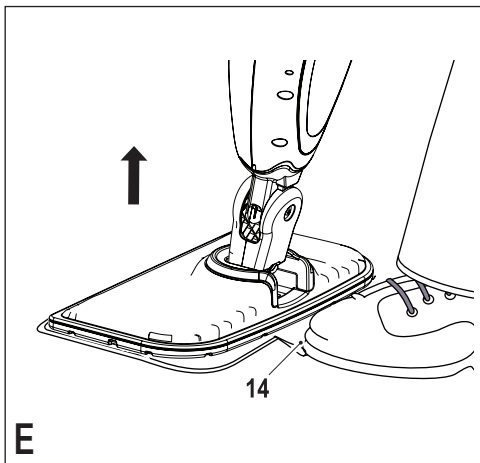
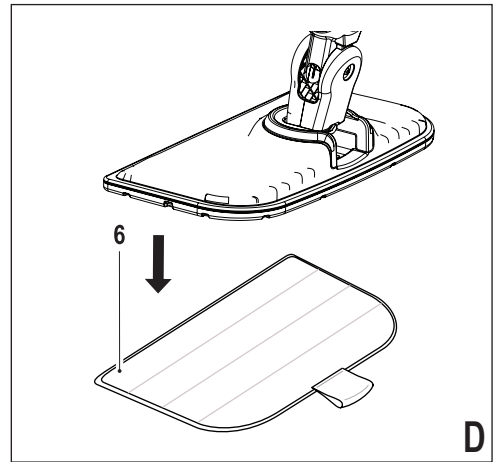
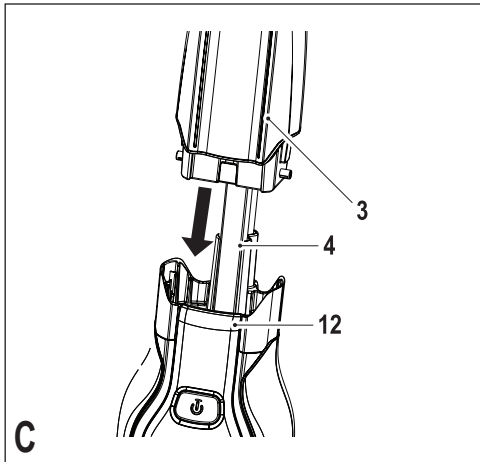
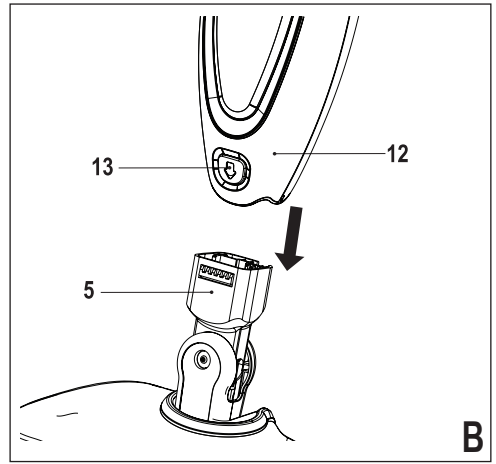
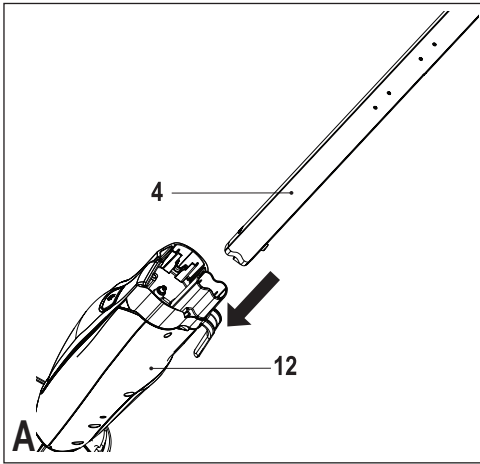
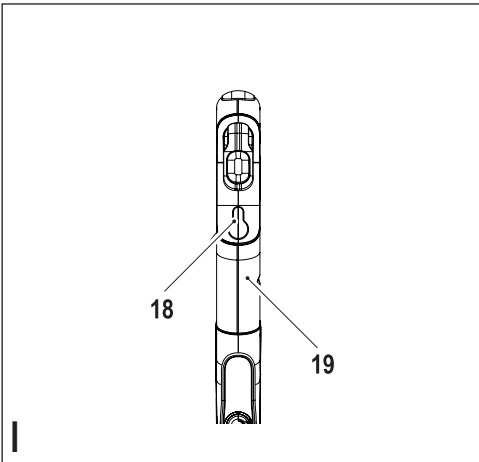
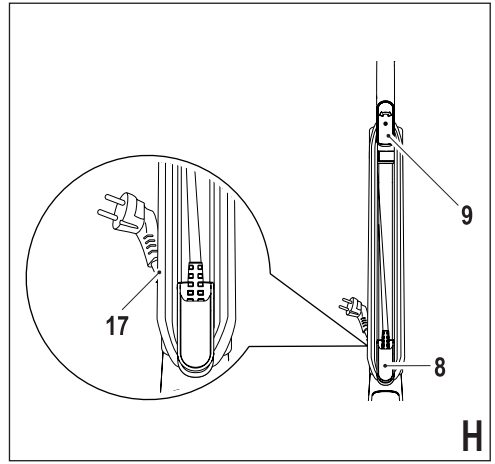
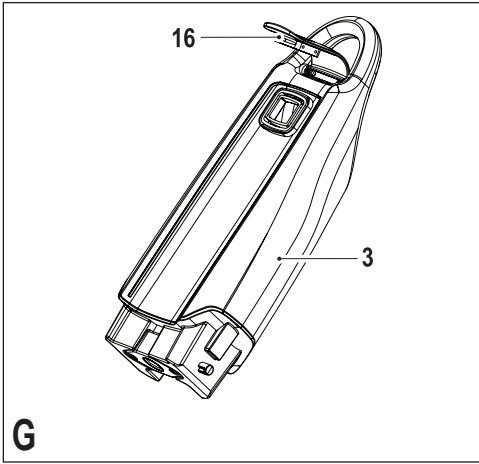

FSM1610 TYPE1/FSM1620 TYPE1

Steam mop

TECHNICAL DATA

		FSM1610 Type1	FSM1620 Type1
Voltage	V _{ac}	220-240	220-240
Power	W	1600	1600
Tank capacity	ml	460	460
Weight	kg	2.6	2.6

Intended use

Your Black & Decker steam mop has been designed for sanitising and cleaning sealed hardwood, sealed laminate, linoleum, vinyl, ceramic tile, stone and marble floors and for refreshing carpets. This appliance is intended for indoor household use only.

Safety instructions



Warning! Read all safety warnings and all instructions. Failure to follow the warnings and instructions listed below may result in electric shock, fire and/or serious injury.



Warning! When using mains-powered appliances, basic safety precautions, including the following, should always be followed to reduce the risk of fire, electric shock, personal injury and material damage.

- ◆ Read all of this manual carefully before using the appliance.
- ◆ The intended use is described in this manual. The use of any accessory or attachment or the performance of any operation with this appliance other than those recommended in this

instruction manual may present a risk of personal injury.

- ◆ Retain this manual for future reference.

Using your appliance

- ◆ Do not direct steam at people, animals, electrical appliances or electrical outlets.
- ◆ Do not expose to rain.
- ◆ Do not immerse the appliance in water.
- ◆ Do not leave the appliance unattended.
- ◆ Do not leave the appliance connected to an electrical outlet when not in use.
- ◆ Never pull the power lead to disconnect the appliance from the socket. Keep the appliance lead away from heat, oil and sharp edges.
- ◆ Do not handle steam cleaner with wet hands.
- ◆ Do not pull or carry by cord, use cord as a handle, close door on cord, pull cord around sharp corners or expose cord to heated surfaces.
- ◆ Do not use appliance in an enclosed space filled with vapour given off by oil-base paint thinner, some moth-proofing substances, flammable dust, or other explosive or toxic vapours.
- ◆ Check the type of floor with the manufacturer.
- ◆ Do not use on leather, wax polished furniture or floors, synthetic fabrics, velvet or other delicate, steam-sensitive materials.



Warning! Do not use on unsealed wood or unsealed laminate floors. On surfaces that have been treated with wax or some no wax floors, the sheen may be removed by the heat and steam action. It is always recommended to test an isolated area of the surface to be cleaned before proceeding. We also recommend that you check the use and care instructions from the floor manufacturer.

- ◆ Never put descaling, aromatic, alcoholic or detergent products into the steam cleaner, as this may damage it or make it unsafe for use.
- ◆ If the home circuit breaker activates while using the steam function, discontinue product use immediately and contact the customer support centre. (Beware of the risk of electrical shock.)
- ◆ The appliance emits very hot steam to sanitize the area of use. This means that the steam head, cleaning pads and carpet attachment get very hot during use.
- ◆ **Caution!** Always wear suitable shoes when using your steam mop and when changing the accessories on your steam mop. Do not wear slippers or open toed footwear.
- ◆ The lid may become hot during use.
- ◆ Steam may escape from the appliance during use.

- ◆ Care should be taken when using this appliance. DO NOT touch any parts which may become hot during use.
- ◆ Switch the appliance off and return the handle to the upright position before removing the water tank.
- ◆ For floor use only; do not use the unit upside down. This appliance is intended for indoor household use only.

After use

- ◆ Unplug the appliance and allow to cool before cleaning.
- ◆ When not in use, the appliance should be stored in a dry place.
- ◆ Children should not have access to stored appliances.

Inspection and repairs

- ◆ Unplug the appliance and allow to cool before performing any maintenance or repairs.
- ◆ Before use, check the appliance for damaged or defective parts. Check for breakage of parts, damage to switches and any other conditions that may affect its operation.
- ◆ Regularly check the power lead for damage.
- ◆ Do not use the appliance if any part is damaged or defective.
- ◆ Have any damaged or defective parts repaired or replaced by an authorized repair agent.
- ◆ Never attempt to remove or replace any parts other than those specified in this manual.

Safety of others

- This appliance can be used by children aged from 8 years and above and persons with reduced physical, sensory or mental capabilities or lack of experience and knowledge if they have been given supervision or instruction concerning use of the appliance in a safe way and understand the hazards involved. Children shall not play with the appliance. Cleaning and user maintenance shall not be made by children without supervision.
- Children should be supervised to ensure that they do not play with the appliance.

Residual risks.

Additional residual risks may arise when using the tool which may not be included in the enclosed safety warnings. These risks can arise from misuse, prolonged use etc. Even with the application of the relevant safety regulations and the implementation of safety devices, certain residual risks can not be avoided. These include:

- Injuries caused by touching any moving parts.
- Injuries caused by touching any hot parts.
- Injuries caused when changing any parts or accessories.
- Injuries caused by prolonged use of the appliance. When using any appliance for prolonged periods ensure you take regular breaks.

Electrical safety



Warning! This product must be earthed. Always check that the power supply corresponds to the voltage on the rating plate.

Power plugs must match the outlet. Never modify the plug in any way. Unmodified plugs and matching outlets will reduce risk of electric shock.

- If the supply cord is damaged, it must be replaced by the manufacturer or an authorised Black & Decker Service Centre in order to avoid a hazard.

Extension cables & Class 1 product

- A 3-core cable must be used as your appliance is earthed and of Class 1 construction.
- Up to 30m (100 ft) can be used without loss of power.

Labels on the appliance

The following pictograms are shown on the tool:



Warning! To reduce the risk of injury, the user must read the instruction manual.



Warning! Danger of scalding.

Features

This appliance includes some or all of the following features.

1. ON/Off switch
2. Autoselect™ dial
3. Removable water tank
4. Handle
5. Steam head
6. Steam head cleaning pad
7. Resting mat
8. Bottom cable tidy hook
9. Top cable tidy hook
10. Cable management clip
11. Carpet Glider (FSM1620 Only)

Assembly

Warning! Before attempting any of the following operations, make sure that the appliance is switched off and unplugged and that the appliance is cold and does not contain any water.

Attaching the handle (Fig. A)

- ◆ Slide the bottom end of the handle (4) into the top end of the steam mop body (12) until it clicks into place.

Attaching the steam head (Fig. B)

- ◆ Slide the bottom end of the steam mop body (12) onto the steam head (5) until it clicks into place.
- ◆ The steam head can be removed from the Steam mop body by pressing the steam head release button (13) and pulling the steam mop body (12) off the steam head (5).

Attaching the water jug (Fig. C)

- ◆ Clip the water jug (3) onto the handle (4).
- ◆ Slide the water jug (3) down into the Steam mop body (12), ensure that the water jug is firmly seated.

Attaching a cleaning pad (Fig. D)

Replacement cleaning pads are available from your Black & Decker dealer:- (cat. no. FSMP20-XJ).

- ◆ Place a cleaning pad (6) on the floor with the 'hook & loop' side facing up.
- ◆ Lightly press the steam mop down onto the cleaning pad (6).

Caution! Always place your steam mop on the resting mat (7) with the handle (4) in the upright position when stationary and make sure the steam mop is turned off when not in use.

Removing a cleaning pad (Fig. E)

Caution! Always wear suitable shoes when changing the cleaning pad on your steam mop. Do not wear slippers or open toed footwear.

- ◆ Return the handle (4) to the upright position and turn the steam mop 'OFF'.
- ◆ Place the steam mop on the resting mat and wait until it cools down. (approximately five minutes)
- ◆ Place the front of your shoe onto the cleaning pad removal tab (14) and press down firmly.
- ◆ Lift the steam mop up off the cleaning pad.

Caution! Always place the steam mop on the resting mat (7) with the handle (4) in the upright position when stationary and make sure the steam mop is turned off when not in use.

Attaching the carpet glider (Fig. F) (FSM1620 Only)

- ◆ Place carpet glider on the floor.
- ◆ Lightly press the steam mop down onto the carpet glider (11) until it clicks into place.

Caution! Always place the steam mop on the resting mat (8) with the handle (4) in the upright position when stationary and make sure the steam mop is turned off when not in use.

Removing the carpet glider (Fig. F) (FSM1620 Only)

Caution! Always wear suitable shoes when changing the carpet glider on your steam mop. Do not wear slippers or open toed footwear.

- ◆ Return the handle (4) to the upright position and turn the steam mop 'OFF'.
- ◆ Place the steam mop on the resting mat and wait until it cools down. (approximately five minutes)
- ◆ Place the front of your shoe onto the carpet glider removal tab (15) and press down firmly.
- ◆ Lift the steam mop up off the carpet glider (9).

Caution! Always place the steam mop on the resting mat (8) with the handle (4) in the upright position when stationary and make sure the steam mop is turned off when not in use.

Filling the water tank (Fig. G)

The watertank on your steam mop is removable for convenient and easy filling.

This Steam Mop incorporates an anti-calc system to help prolong the life of the system.

Note: Fill the water tank with clean tap water.

Note: In areas of very hard water, the use of de-ionised water is recommended.

- ◆ Remove the water tank (3).
- ◆ Open the filler cap (16) by lifting it up.
- ◆ Fill the water tank (3) with water.

Warning! Your water tank has a 0.5 litre capacity. Do not over fill the tank.

- ◆ Re-fit the filler cap (14).
- ◆ Re-fit the water tank (3).

Note: Ensure the filler cap is firmly secured.

Use

Important! This unit will kill 99.9% of bacteria & germs when used in accordance with this manual and with the micro fibre pad fitted and a continuous run time of 90 seconds.

Switching on and off

- ◆ To switch the appliance on, press the ON/OFF button (1). It takes approximately 15 seconds for the steam mop to heat up.

Note: When the steam mop is first turned on the water reservoir will glow red. Once the steam mop is ready to use the water reservoir will glow blue.

- ◆ To switch the appliance off, press the ON/OFF button (1).

Caution! Never leave the steam mop in one spot on any surface for any period of time. Always place the steam mop on the resting mat (7) with the handle (4) in the upright position when stationary and make sure the steam mop is turned off when not in use.

Caution! Always empty the steam mop after use.

Autoselect™ Technology

This steam mop is fitted with an Autoselect™ dial (2) which shows various cleaning applications. They are used to select the correct operating mode for your particular cleaning operation.

Using the Autoselect™ dial (2), choose from one of the following applications:

	Wood/Laminate
	Stone/Marble
	Tiles/Vinyl

The steam mop will select the correct volume of steam required for your particular cleaning operation.

Note: Always check you are using the correct setting before using your steam mop.

Hints for optimum use

General

Caution! Never use the steam mop without first attaching a cleaning pad.

- ◆ During use you can use the cable management clip (10) to keep your cable out of the way of the work area..
- ◆ Always vacuum or sweep the floor before using the steam mop.
- ◆ The easiest way to use the machine is to tilt the handle to a 45° angle and clean slowly, covering a small area at a time.

- ◆ Do not use chemical cleaners with your steam mop. To remove stubborn stains from vinyl or linoleum floors, you can pre-treat with a mild detergent and some water before using the steam mop.

Steam cleaning

- ◆ Place a cleaning pad (6) on the floor with the 'hook & loop' side facing up.
- ◆ Raise the steam mop off the resting mat (7) and lightly press it down onto the cleaning pad (6).
- ◆ Place the steam mop on the resting mat.
- ◆ Connect the steam mop to the mains.
- ◆ Turn the Autoselect™ dial (2) to the required setting.
- ◆ Press the ON/OFF button (1). It takes approximately 15 seconds for the steam mop to heat up.
- ◆ Pulling the handle (4) back will activate the steam pump. After a few seconds steam will start to come out of the steam head.
- ◆ It takes a few seconds for steam to enter the cleaning pad. The steam mop will now glide easily over the surface to be sanitised/cleaned.
- ◆ Push and pull the steam mop slowly across the floor to thoroughly steam clean each section.

Note: During use you may turn off the steam pump by returning the handle to the upright position, this convenient feature will allow you to place the steam mop on the resting mat for a short time so that you may move items of furniture, then continue cleaning without the need to switch the appliance off.

- ◆ When you have finished using the steam mop, return the handle (4) to the upright position and turn it 'OFF', place it on the resting mat (7) and wait until the steam mop cools down. (approximately five minutes)

Caution! It is important to monitor the water level in the water tank. To refill the water tank and continue to sanitise/clean, return the handle (4) to the upright position and turn the steam mop 'OFF'. Unplug the unit from the electrical wall outlet, remove and refill the water tank (3).

Caution! Never leave the steam mop in one spot on any surface for any period of time. Always place the steam mop on the resting mat (7) with the handle (4) in the upright position when stationary and make sure the steam mop is turned off when not in use.

After use (Fig. H & I)

- ◆ Return the handle (4) to the upright position and turn the steam mop 'OFF',
- ◆ Place the steam mop on the resting mat (7) and wait until the steam mop cools down. (approximately five minutes)
- ◆ Unplug the steam mop from the electrical wall outlet.
- ◆ Empty the water tank (3).
- ◆ Remove the cleaning pad (6) and wash it ready for next use. (Take care to follow the wash care instructions printed on the cleaning pad).

- ◆ Wrap the supply cable around the cable tidy hooks (8 & 9).

Note: The top cable tidy hook (9) rotates to easily release the cable ready for next use.

- ◆ Clip the supply cable onto itself using the cable tidy clip (17) close to the plug.
- ◆ Place steam mop on the resting mat (7) for storage.

Note: With the handle (4) in the upright position, the cable neatly wrapped around the cable tidy hooks (8 & 9) and secured with the cable tidy clip (17) your steam mop will stand on its own for storage. Alternatively there is a hanging bracket (18) built into the hand grip (19) which will allow your steam mop to be hung from a suitable hook on the wall. Always ensure that your wall hook is capable of supporting the weight of the steam mop safely.

Maintenance and cleaning

Your Black & Decker corded appliance has been designed to operate over a long period of time with a minimum of maintenance. Continuous satisfactory operation depends upon proper appliance care and regular cleaning.

Warning! Before performing any maintenance or cleaning on corded appliances switch off and unplug the appliance.

- ◆ Wipe your appliance over using a soft damp cloth.
- ◆ For stubborn marks you can use a mild solution of soap and water to dampen your cloth.

Care of the cleaning pads

Wash care instructions - No fabric conditioner - Allow to dry fully before re-use.

Caution! Follow the cleaning instructions printed on the label of the cleaning pad.

Protecting the environment



Separate collection. This product must not be disposed of with normal household waste.

Should you find one day that your Black & Decker product needs replacement, or if it is of no further use to you, do not dispose of it with household waste. Make this product available for separate collection.



Separate collection of used products and packaging allows materials to be recycled and used again. Re-use of recycled materials helps prevent environmental pollution and reduces the demand for raw materials.

Local regulations may provide for separate collection of electrical products from the household, at municipal waste sites or by the retailer when you purchase a new product.

Service Information

Black & Decker offers a full network of company-owned and authorized service locations throughout Asia. All Black & Decker Service Centers are staffed with trained personnel to provide customers with efficient and reliable product service.

Whether you need technical advice, repair, or genuine factory replacement parts, contact the Black & Decker location nearest to you.

NOTE

- ◆ Black & Decker's policy is one of continuous improvement to our products and, as such, we reserve the right to change product specifications without prior notice.
- ◆ Standard equipment and accessories may vary by country.
- ◆ Product specifications may differ by country.
- ◆ Complete product range may not be available in all countries. Contact your local Black & Decker dealers for range availability.

FSM1610 TYPE1/FSM1620 TYPE1 蒸汽拖把

技术参数

		FSM1610 TYPE1	FSM1620 TYPE1
电压	V _{ac}	220-240	220-240
功率	W	1600	1600
水箱容量	ml	460	460
重量	kg	2.6	2.6

设计用途

Black & Decker 蒸汽拖把设计用于清洁与清洗密封实木地板、密封复合地板、油地毡地板、乙烯基地板、瓷砖地板、石地板，以及大理石地板。本设备仅适用于室内家庭用途。

安全说明



警告！ 请仔细阅读所有安全警告和指示说明。如不遵守以下任何警告和指示说明，可能会导致触电、火灾和/或严重伤害。



警告！ 使用主电源供电的设备时，请务必始终遵守下列基本安全预防措施，从而降低火灾、触电、人身伤害和材料损坏等风险。

- ◆ 使用设备前，请仔细阅读本手册。
- ◆ 本手册描述了设备的设计用途。如果配件或附件的使用、本设备的操作超出本手册建议的范围，则可能出现人身伤害的危险。
- ◆ 请保存好本手册，以备将来查阅。

使用设备时

- ◆ 请勿将蒸汽对准人、动物、电器或电气插座。
- ◆ 请勿将设备暴露在雨中。
- ◆ 请勿将设备浸入水中。
- ◆ 请勿将设备闲置在一旁。
- ◆ 本设备未使用时，请勿将其连接到插座上。
- ◆ 禁止猛力拉扯电源线以使设备断开与插座的连接。请确保设备远离热源、油脂及尖锐的边缘。
- ◆ 请勿湿手接触蒸汽拖把。
- ◆ 请勿使用电源线拉动或搬运设备，不得把电源线当做搬运手柄、把电源线夹在门缝中、在尖角周围拉动电源线或将电源线暴露在受热表面。
- ◆ 请勿在充满油漆挥发物、防蛀药品、易燃粉尘、易爆或有毒气体的封闭空间内使用本设备。
- ◆ 请与制造商核实地板的类型。
- ◆ 请勿在皮革、蜡抛光家具或地板、合成纤维、丝绒或其他脆弱的、对蒸汽敏感的材料上使用本

设备。



警告！ 请勿将本工具用于未密封木地板或未密封复合地板。对于打蜡地板或某些无蜡地板，热和蒸汽作用可能使其表面光泽消失。在开始清洁前，建议在待清洁表面上隔离一块区域做实验。此外，还建议您参考地板制造商的使用与保养须知。

- ◆ 禁止将除锈、芳烃、乙醇或清洁剂等物品放入蒸汽拖把中。这会损坏设备或使设备变得不安全。
- ◆ 使用蒸汽功能时，如果家里的电路断路器启动，请立即停止使用本产品并与客户支持中心联系。（请当心触电危险。）
- ◆ 本设备会发出非常热的蒸汽，用于清洁目的。这意味着在使用过程中，蒸汽头、清洁垫和地毯附件会变得很烫。
- ◆ **小心！** 使用本蒸汽拖把或更换其配件时，请务必穿上合适的鞋子。请勿穿拖鞋或露趾鞋。
- ◆ 使用过程中，设备盖子会变得很烫。
- ◆ 使用过程中，蒸汽可能会从设备内逸出。
- ◆ 使用本设备时，请务必小心；使用过程中，请勿接触任何可能变热的部件。
- ◆ 将水箱取下之前，关闭设备开关并恢复手柄到竖直位置。
- ◆ 仅可用于地板，请勿倒置使用。本设备仅适用于室内家庭用途。

使用后

- ◆ 拔下设备插头，待冷却后，再清洁设备。
- ◆ 不使用设备时，应存放于干燥场所。
- ◆ 应将设备存放在儿童接触不到的地方。

检查与维修

- ◆ 拔下设备插头，待设备冷却后，再进行维护与维修。
- ◆ 使用前，请检查设备是否受损或存在缺陷部件。检查部件是否破裂、开关是否损坏，以及是否存在影响设备操作的其它情况。
- ◆ 定期检查电源线是否损坏。
- ◆ 如果部件损坏或存在缺陷，请勿使用设备。
- ◆ 损坏或缺陷部件必须交由授权维修代理处维修与更换。
- ◆ 禁止试图拆卸或更换本手册规定之外的任何部件。

他人安全

- ◆ 在有他人监督的情况下，或在接受过安全使用该产品的指导并已了解了可能存在的危险的情况下，8岁或以上的儿童，以及身体、感官或精神较差的人员，或者对该类产品缺少使用经验和认识的人员，也可以使用本设备。确保儿童

没有耍玩本设备。在没有他人监督的情况下，禁止儿童使用本设备或对其进行维护保养。

- ◆ 必须监督儿童，确保他们没有玩耍本设备。

其他风险

使用设备时，可能出现本安全警示之外的其他风险。这些风险可能来自使用不当，使用时间过长等。尽管遵守了相关的安全法规并采用了安全装备，某些风险仍然是无法避免的。这些风险包括：

- ◆ 接触运动部件导致的人身伤害。
- ◆ 接触发热部件导致的人身伤害。
- ◆ 更换部件或配件时导致的人身伤害。
- ◆ 长时间使用本设备导致的人身伤害。长期使用任何设备时，均应定期休息。

电气安全



警告！本产品必须接地。请务必检查电源是否与铭牌上的电压一致。

电源插头必须与同规格的插座相配。禁止以任何方式改装插头。未经改装的插头与同规格的插座将降低触电风险。

- ◆ 如果电源线损坏，必须让制造商或 Black & Decker 授权服务中心更换以避免发生危险。

延长线与 1 类产品

- ◆ 本设备为接地设备，并具备 1 类构造，因此必须使用 3 芯延长线。
- ◆ 无功率损失条件下，最长可使用 30 米（100 英尺）延长线。

设备上的标签

工具有下列标志：



警告！为降低伤害风险，用户必须阅读使用手册。



警告！烫伤危险。

部件名称

本设备包含如下部分或全部部件。

1. 开关
2. Autoselect™ 旋钮
3. 可拆卸水箱
4. 手柄
5. 蒸汽头
6. 蒸汽头清洁垫
7. 停机垫

8. 底端电源线整理钩
9. 顶端电源线整理钩
10. 电源线管理夹扣
11. 地毯助滑器（仅用于 FSM1620）

组装

警告！进行如下任何操作之前，请确保关闭设备开关、拔下设备插头、设备处于冷却状态并且不含水。

安装手柄（图 A）

- ◆ 将手柄 (4) 底端向蒸汽拖把机身 (12) 顶端滑动，直至啮合到位。

安装蒸汽头（图 B）

- ◆ 将蒸汽拖把机身 (12) 底端向蒸汽头 (5) 滑动，直至啮合为止。
- ◆ 按下蒸汽头释放按钮 (13)，同时将蒸汽拖把机身 (12) 拉出蒸汽头 (5)，就能把蒸汽头取下。

安装水杯（图 C）

- ◆ 将水杯 (3) 夹到手柄上 (4)。
- ◆ 将水杯 (3) 朝蒸汽拖把机身 (12) 向下滑动，确保水杯安装牢固。

安装清洁垫（图 D）

Black & Decker 代理商均提供备用清洁垫（货号：FSMP20-XJ）。

- ◆ 将清洁垫 (6) 置于地板上，“魔术扣”朝上。
- ◆ 将蒸汽拖把往清洁垫 (6) 上轻压。

小心！蒸汽拖把处于静止状态时，切记将其置于停机垫 (7) 上，并且使手柄 (4) 保持竖直位置；未使用蒸汽拖把时，请确保将其开关关闭。

取下清洁垫（图 E）

小心！给蒸汽拖把更换清洁垫时，请务必穿上合适的鞋子。请勿穿拖鞋或露趾鞋。

- ◆ 将手柄 (4) 恢复到竖直位置，关闭蒸汽拖把电源开关。
- ◆ 将蒸汽拖把置于停机垫上，待其冷却（大约需要五分钟）。
- ◆ 请将自己一只鞋子的前部放在清洁垫拆卸卡 (14) 上，用力向下踩。
- ◆ 将蒸汽拖把向上拉，使其离开清洁垫。

小心！蒸汽拖把处于静止状态时，切记将其置于停机垫 (7) 上，并且使手柄 (4) 保持竖直位置；未使用蒸汽拖把时，请确保将其开关关闭。

安装地毯助滑器 (图 F) (仅用于 FSM1620)

- ◆ 将地毯助滑器置于地板上。
- ◆ 把蒸汽拖把对准地毯助滑器 (11) 轻压, 直至啮合到位。

小心! 蒸汽拖把处于静止状态时, 切记将其置于停机垫 (8) 上, 并且使手柄 (4) 保持竖直位置; 未使用蒸汽拖把时, 请确保将其开关关闭。

取下地毯助滑器 (图 F) (仅用于 FSM1620)

小心! 给蒸汽拖把更换地毯助滑器时, 请务必穿上合适的鞋子。请勿穿拖鞋或露趾鞋。

- ◆ 将手柄 (4) 恢复到竖直位置, 关闭蒸汽拖把电源开关。
- ◆ 将蒸汽拖把置于停机垫上, 待其冷却 (大约需要五分钟)。
- ◆ 请将自己一只鞋子的前部放在地毯助滑器拆卸卡 (15) 上, 用力向下踩。
- ◆ 将蒸汽拖把向上拉, 使其离开地毯助滑器 (9)。

小心! 蒸汽拖把处于静止状态时, 切记将其置于停机垫 (8) 上, 并且使手柄 (4) 保持竖直位置; 未使用蒸汽拖把时, 请确保将其开关关闭。

给水箱加水 (图 G)

本蒸汽拖把的水箱为可拆卸水箱, 方便加水, 使用便利。

本蒸汽拖把配有除垢系统, 有助于延长设备的使用寿命。

注: 请给水箱加装清洁的自来水。

注: 如果您地区的自来水水质非常硬, 建议您使用去离子水。

- ◆ 取下水箱 (3)。
- ◆ 将注水口盖子 (16) 向上拉以打开盖子。
- ◆ 给水箱 (3) 加水。

警告! 本水箱的容量为 0.5 升。请勿超过水箱的最高水位线。

- ◆ 重新装上注水口盖子 (14)。
- ◆ 重新装上水箱 (3)。

注: 确保注水口盖子已经稳固安装。

使用步骤

重要! 若按照本手册操作、使用装配的微纤维垫, 并连续运行 90 秒, 本装置将消灭 99.9% 的细菌。

启动与关闭

- ◆ 要启动设备, 请按下开关 (1)。蒸汽拖把需要大约 15 秒钟进行加热。

注: 刚启动蒸汽拖把时, 水箱将发出红光。一旦蒸汽拖把可以开始操作时, 水箱将发出蓝光。

- ◆ 要关闭设备, 请按下开关 (1)。

小心! 禁止让蒸汽拖把长时间停留在任一工作表面上。蒸汽拖把处于静止状态时, 切记将其置于停机垫 (7) 上, 并且使手柄 (4) 保持竖直位置; 未使用蒸



汽拖把时, 请确保将其开关关闭。

小心! 使用后, 请务必清空蒸汽拖把。

Autoselect™ 技术

本蒸汽拖把装有 Autoselect™ 旋钮 (2), 该旋钮提供各种清洁用途指示。您可以根据清洁用途, 设定正确的操作模式。

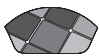
使用 Autoselect™ 旋钮 (2), 在下表用途中选择其一:

	实木地板/复合地板
	石地板/大理石地板
	瓷砖地板/乙烯基地板

本蒸汽拖把会根据您的特殊清洁用途, 选择合适的蒸汽流量。

注: 使用蒸汽拖把之前, 请务必确保您正在使用正确的设置。

最佳使用提示

一般原则

小心! 禁止在未安装清洁垫的情况下使用蒸汽拖把。

- ◆ 使用蒸汽拖把时, 您可以使用电源线管理夹扣 (10) 收纳电源线, 使电源线与工作区域保持一定安全距离。
- ◆ 使用蒸汽拖把前, 请务必使用吸尘器或扫把将地板上的灰尘清除干净。
- ◆ 本产品最简单的使用方法就是将手柄倾斜至 45° 角, 慢慢清洁, 每次只清洁一小片地方。
- ◆ 请勿将蒸汽拖把与化学清洁剂一起使用。要清除乙烯基地板或油地毡地板上的顽固污渍, 可在使用蒸汽拖把前, 用温和洗涤剂 and 适量的水进行处理。

蒸汽清洁

- ◆ 将清洁垫 (6) 置于地板上, “魔术扣”朝上。
- ◆ 将蒸汽拖把从停机垫 (7) 上提起, 然后往清洁垫 (6) 上轻压。
- ◆ 将蒸汽拖把置于停机垫上。
- ◆ 将蒸汽拖把连接至主电源。
- ◆ 旋转 Autoselect™ 旋钮 (2) 至所需设定。
- ◆ 按下开关 (1)。蒸汽拖把需要大约 15 秒钟进行加热。
- ◆ 将手柄 (4) 向后拉, 启动蒸汽泵。数秒后, 蒸汽将从蒸汽头中涌出。
- ◆ 蒸汽需要数秒钟时间进入清洁垫。完成以上步骤后, 蒸汽拖把将能轻松在待清洁/清洗的表面

上滑动。

- ◆ 在地板上慢慢推拉蒸汽拖把，用蒸汽彻底清洁地板的各个角落。

注：使用时，只需将手柄恢复到竖直位置，即可关闭蒸汽泵。此功能非常方便，无需关闭整个设备即可将蒸汽拖把（短时间）置于停机垫上，以便腾出时间来搬动家具等物品，然后继续清洁工作。

- ◆ 蒸汽拖把使用完毕后，将手柄 (4) 恢复到竖直，关闭蒸汽拖把电源开关，并置于停机垫 (7) 上，待其冷却（大约需要五分钟）。

小心！使用时，监控水箱水位非常重要。要将水箱重新注满，并继续清洁/清洗，请将手柄 (4) 恢复到竖直位置，关闭蒸汽拖把电源开关。从墙面插座上拔下工具插头，然后取下并重新注满水箱 (3)。

小心！禁止让蒸汽拖把长时间停留在任一工作表面上。蒸汽拖把处于静止状态时，切记将其置于停机垫 (7) 上，并且使手柄 (4) 保持竖直位置；未使用蒸汽拖把时，请确保将其开关关闭。

使用后 (图H及图I)

- ◆ 将手柄 (4) 恢复到竖直位置，关闭蒸汽拖把电源开关。
- ◆ 将蒸汽拖把置于停机垫 (7) 上，待其冷却（大约需要五分钟）。
- ◆ 从墙面插座上拔下蒸汽拖把插头。
- ◆ 清空水箱 (3)。
- ◆ 取下并清洗清洁垫 (6)，以备下次使用。（请务必按照清洁垫上印刷的清洗须知进行清洗）。
- ◆ 将电源线缠绕在电源线整理钩 (8及9) 上。

注：再次使用时，可以旋转顶端电源线整理钩 (9)，轻易取下电源线。

- ◆ 将电源线上靠近插头的地方夹到电源线整理钩 (17) 上。
- ◆ 将蒸汽拖把置于停机垫 (7) 上，以便存放。

注：手柄 (4) 保持竖直位置，电源线整齐地盘绕在电源线整理钩 (8及9) 上，并固定到电源线整理夹 (17) 中的情况下，本蒸汽拖把存放时就能够自行站立。您也可以使用手柄 (19) 内置的吊钩 (18) 将蒸汽拖把挂到墙上一个符合其重量标准的挂钩上。请务必确保所使用的挂钩能够安全地承受蒸汽拖把的重量。

维护与清洁

Black & Decker 有线设备设计精良，可以长期使用，而且只需最少的维护。要连续获得令人满意的工作效果，需要进行合适的设备保养和定期清洁。

警告！在对有线设备进行任何维护或清洁前，请关闭设备电源并拔下插头。

- ◆ 使用软质湿布擦拭整个设备。
- ◆ 清除顽固污渍时，可以使用软布蘸温和的肥皂水擦拭。

保养清洁垫

清洗须知：不得使用织物调节剂，再次使用前，应待其彻底干透。

小心！请按照清洁垫上印刷的清洗须知进行清洗。

环境保护



分类回收。本产品不得与普通家庭垃圾一起处理。

如果您发现您的 Black & Decker 产品需要进行替换，或您已经不再需要使用这些产品，请勿将它们与家庭废物一起处理。请将它们单独分类回收。



分类回收使用过的产品和包装能够让材料得以再循环和再利用。再生材料的再利用有助于防止环境污染，并降低对原材料的需求。

当地法规可能要求由市政废物处理点或向您出售新产品的零售商提供从家庭中分类回收电气产品的服务。

服务信息

Black & Decker 提供覆盖整个亚洲的公司隶属和授权服务地点。所有的 Black & Decker 服务中心都具有训练有素的人员，为客户提供高效和可靠的产品服务。

不论是需要技术建议、维修或原厂替换部件，请联系最靠近您的 Black & Decker 地点。

注：

- ◆ Black & Decker 的政策是持续改进我们的产品，因此，我们保留随时更改产品规格的权利，恕不另行通知。
- ◆ 标准设备和附件可能会因为不同的国家而有所不同。
- ◆ 产品规格可能会因为不同的国家而有所不同。
- ◆ 并非所有的国家都有提供完整的产品系列。有关各产品系列的供应情况，请联系您当地的 Black & Decker 代理商。

