

**PRO
LINE**

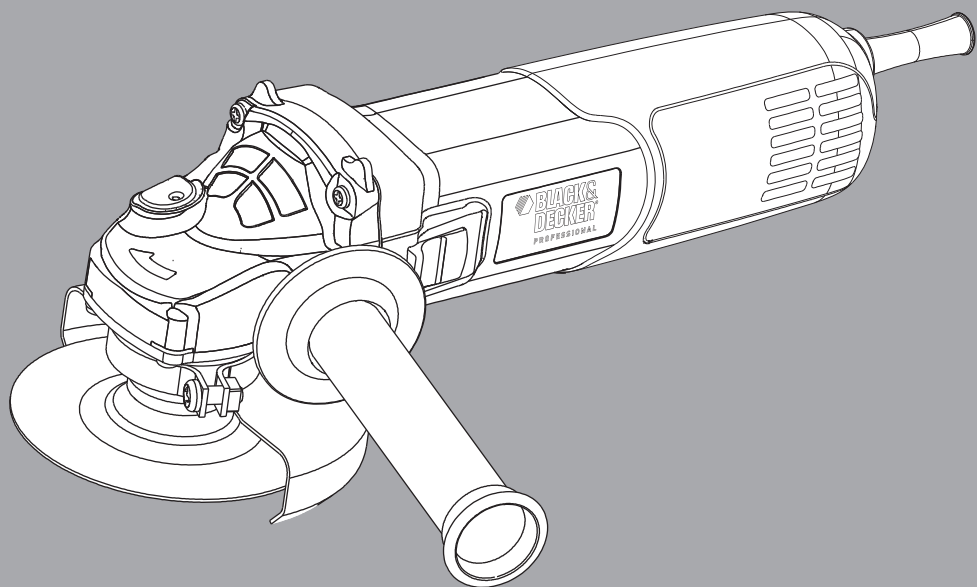

BLACK & DECKER®



www.blackanddeckerindia.in

BPGS8100
BPGS8115

Figure 1

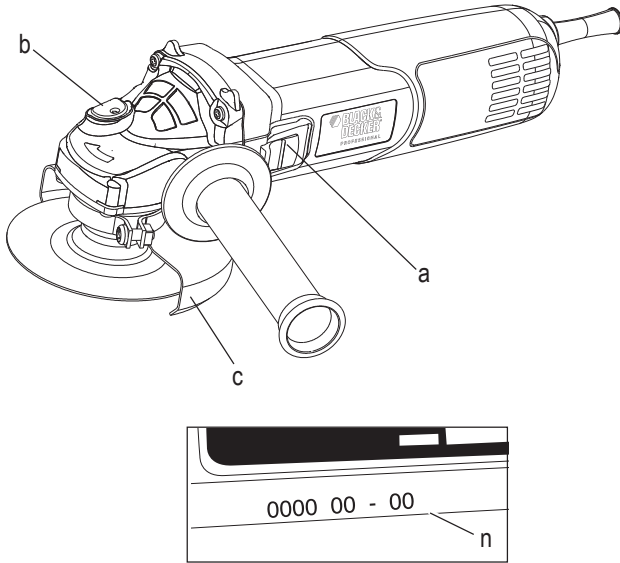

Figure 2

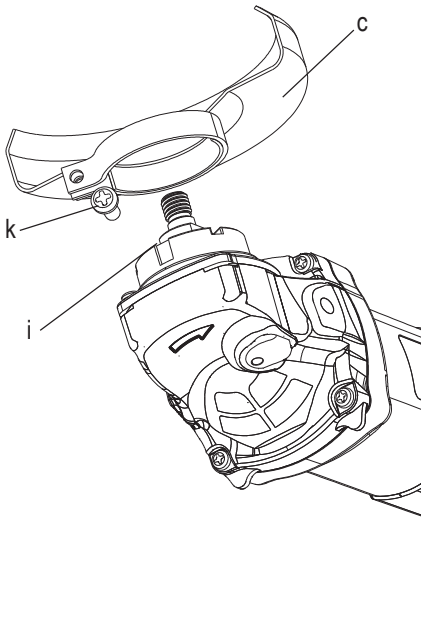

Figure 3

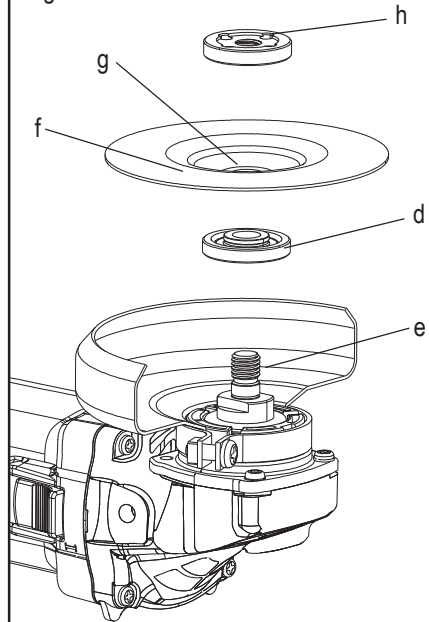

Figure 4

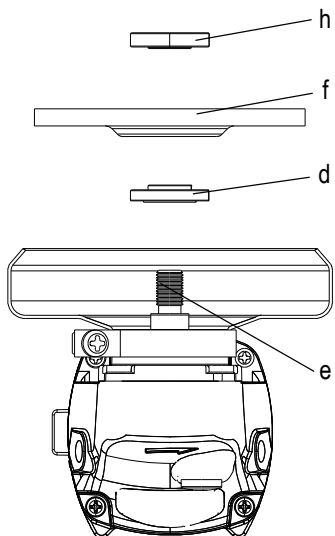

Figure 5

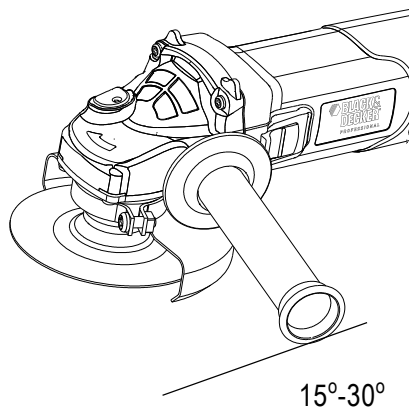
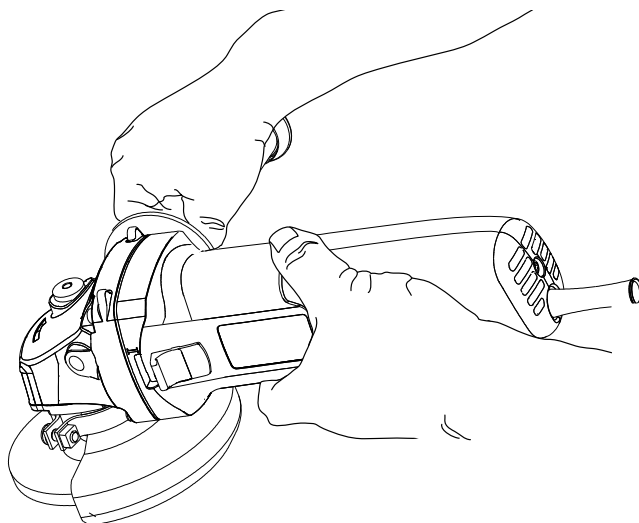

Figure 6



Definitions: Safety Guidelines

The definitions below describe the level of severity for each signal word. Please read the manual and pay attention to these symbols.



Danger: Indicates an imminently hazardous situation which, if not avoided, **will result in death or serious injury**.



Warning: Indicates a potentially hazardous situation which, if not avoided, **could result in death or serious injury**.



Caution: Indicates a potentially hazardous situation which, if not avoided, **may result in minor or moderate injury**.

Notice: Indicates a practice **not related to personal injury** which, if not avoided, **may result in property damage**.



Denotes risk of electric shock.



Denotes risk of fire.



Warning: To reduce the risk of injury, read the instruction manual.

General Power Tool Safety Warnings



Warning: Read all safety warnings and all instructions. Failure to follow the warnings and instructions may result in electric shock, fire and/or serious injury.

Save all warnings and instructions for future reference

The term “power tool” in the warnings refers to your mains-operated (corded) power tool or battery-operated (cordless) power tool.

1) Work area safety

- a) **Keep work area clean and well lit.** Cluttered or dark areas invite accidents.
- b) **Do not operate power tools in explosive atmospheres, such as in the presence of flammable liquids, gases or dust.** Power tools create sparks which may ignite the dust or fumes.
- c) **Keep children and bystanders away while operating a power tool.** Distractions can cause you to lose control.

2) Electrical safety

- a) **Power tool plugs must match the outlet. Never modify the plug in any way. Do not use any adapter plugs with earthed (grounded) power tools.** Unmodified plugs and matching outlets will reduce risk of electric shock.
- b) **Avoid body contact with earthed or grounded surfaces such as pipes, radiators, ranges and refrigerators.** There is an increased risk of electric shock if your body is earthed or grounded.
- c) **Do not expose power tools to rain or wet conditions.** Water entering a power tool will increase the risk of electric shock.
- d) **Do not abuse the cord. Never use the cord for carrying, pulling or unplugging the power tool. Keep cord away from heat, oil, sharp edges or moving parts.** Damaged or entangled cords increase the risk of electric shock.
- e) **When operating a power tool outdoors, use an extension cord suitable for outdoor use.** Use of a cord suitable for outdoor use reduces the risk of electric shock.
- f) **If operating a power tool in a damp location is unavoidable, use a residual current device (RCD) protected supply.** Use of an RCD reduces the risk of electric shock.

3) Personal safety

- a) **Stay alert, watch what you are doing and use common sense when operating a power tool. Do not use a power tool while you are tired or under the influence of drugs, alcohol or medication.** A moment of inattention while operating power tools may result in serious personal injury.
- b) **Use personal protective equipment. Always wear eye protection.** Protective equipment such as dust mask, non-skid safety shoes, hard hat, or hearing protection used for appropriate conditions will reduce personal injuries.
- c) **Prevent unintentional starting. Ensure the switch is in the off position before connecting to power source and/or battery pack, picking up or carrying the tool.** Carrying power tools with your finger on the switch or energising power tools that have the switch on invites accidents.

- d) **Remove any adjusting key or wrench before turning the power tool on.** A wrench or a key left attached to a rotating part of the power tool may result in personal injury.
- e) **Do not overreach. Keep proper footing and balance at all times.** This enables better control of the power tool in unexpected situations.
- f) **Dress properly. Do not wear loose clothing or jewellery. Keep your hair, clothing and gloves away from moving parts.** Loose clothes, jewellery or long hair can be caught in moving parts.
- g) **If devices are provided for the connection of dust extraction and collection facilities, ensure these are connected and properly used.** Use of dust collection can reduce dust-related hazards.
- 4) **Power tool use and care**
- a) **Do not force the power tool. Use the correct power tool for your application.** The correct power tool will do the job better and safer at the rate for which it was designed.
- b) **Do not use the power tool if the switch does not turn it on and off.** Any power tool that cannot be controlled with the switch is dangerous and must be repaired.
- c) **Disconnect the plug from the power source and/or the battery pack from the power tool before making any adjustments, changing accessories, or storing power tools.** Such preventive safety measures reduce the risk of starting the power tool accidentally.
- d) **Store idle power tools out of the reach of children and do not allow persons unfamiliar with the power tool or these instructions to operate the power tool.** Power tools are dangerous in the hands of untrained users.
- e) **Maintain power tools. Check for misalignment or binding of moving parts, breakage of parts and any other condition that may affect the power tool's operation. If damaged, have the power tool repaired before use.** Many accidents are caused by poorly maintained power tools.
- f) **Keep cutting tools sharp and clean.** Properly maintained cutting tools with sharp cutting edges are less likely to bind and are easier to control.
- g) **Use the power tool, accessories and tool bits etc., in accordance with these instructions taking into account the working conditions and the work to be performed.** Use of the power tool for operations different from those intended could result in a hazardous situation.
- 5) **Service**
- a) **Have your power tool serviced by a qualified repair person using only identical replacement parts.** This will ensure that the safety of the power tool is maintained.

Additional specific safety rules

Safety Instructions for All Operations

- a) **This power tool is intended to function as a grinder. Read all safety warnings, instructions, illustrations and specifications provided with this power tool.** Failure to follow all instructions listed below may result in electric shock, fire and/or serious injury.
- b) **Operations such as cutting-off, sander, wire brush or polisher are not recommended to be performed with this power tool.** Operations for which the power tool was not designed may create a hazard and cause personal injury.
- c) **Do not use accessories which are not specifically designed and recommended by the tool manufacturer.** Just because the accessory can be attached to your power tool, it does not assure safe operation.
- d) **The rated speed of the accessory must be at least equal to the maximum speed marked on the power tool.** Accessories running faster than their rated speed can break and fly apart.
- e) **The outside diameter and the thickness of your accessory must be within the capacity rating of your power tool.** Incorrectly sized accessories cannot be adequately guarded or controlled.
- f) **The arbour size of wheels, flanges, backing pads or any other accessory must properly fit the spindle of the power tool.** Accessories with arbour holes that do not match the mounting hardware of the power tool will run out of balance, vibrate excessively and may cause loss of control.

- g) **Do not use a damaged accessory. Before each use inspect the accessory such as abrasive wheel for chips and cracks, backing pad for cracks, tear or excess wear, wire brush for loose or cracked wires. If power tool or accessory is dropped, inspect for damage or install an undamaged accessory. After inspecting and installing an accessory, position yourself and bystanders away from the plane of the rotating accessory and run the power tool at maximum no-load speed for one minute. Damaged accessories will normally break apart during this test time.**
- h) **Wear personal protective equipment. Depending on application, use face shield, safety goggles or safety glasses. As appropriate, wear dust mask, hearing protectors, gloves and workshop apron capable of stopping small abrasive or workpiece fragments. The eye protection must be capable of stopping flying debris generated by various operations. The dust mask or respirator must be capable of filtering particles generated by your operation. Prolonged exposure to high intensity noise may cause hearing loss.**
- i) **Keep bystanders a safe distance away from work area. Anyone entering the work area must wear personal protective equipment.** Fragments of workpiece or of a broken accessory may fly away and cause injury beyond immediate area of operation.
- j) **Hold the power tool by insulated gripping surfaces only, when performing an operation where the cutting accessory may contact hidden wiring or its own cord.** Cutting accessory contacting a "live" wire may make exposed metal parts of the power tool "live" and could give the operator an electric shock.
- k) **Position the cord clear of the spinning accessory.** If you lose control, the cord may be cut or snagged and your hand or arm may be pulled into the spinning accessory.
- l) **Never lay the power tool down until the accessory has come to a complete stop.** The spinning accessory may grab the surface and pull the power tool out of your control.
- m) **Do not run the power tool while carrying it at your side.** Accidental contact with the spinning accessory could snag your clothing, pulling the accessory into your body.
- n) **Regularly clean the power tool's air vents.** The motor's fan will draw the dust inside the housing and excessive accumulation of powdered metal may cause electrical hazards.
- o) **Do not operate the power tool near flammable materials.** Sparks could ignite these materials.
- p) **Do not use accessories that require liquid coolants.** Using water or other liquid coolants may result in electrocution or shock.

Further safety instructions for all operations

Kickback and Related Warnings

Kickback is a sudden reaction to a pinched or snagged rotating wheel, backing pad, brush or any other accessory. Pinching or snagging causes rapid stalling of the rotating accessory which in turn causes the uncontrolled power tool to be forced in the direction opposite of the accessory's rotation at the point of the binding. For example, if an abrasive wheel is snagged or pinched by the workpiece, the edge of the wheel that is entering into the pinch point can dig into the surface of the material causing the wheel to climb out or kick out. The wheel may either jump toward or away from the operator, depending on direction of the wheel's movement at the point of pinching. Abrasive wheels may also break under these conditions. Kickback is the result of tool misuse and/or incorrect operating procedures or conditions and can be avoided by taking proper precautions as given below:

- a) **Maintain a firm grip on the power tool and position your body and arm to allow you to resist kickback forces. Always use auxiliary handle, if provided, for maximum control over kickback or torque reaction during start up.** The operator can control torque reaction or kickback forces, if proper precautions are taken.
- b) **Never place your hand near the rotating accessory.** Accessory may kickback over your hand.
- c) **Do not position your body in the area where power tool will move if kickback occurs.** Kickback will propel the tool in direction opposite to the wheel's movement at the point of snagging.

- d) **Use special care when working corners, sharp edges etc. Avoid bouncing and snagging the accessory.** Corners, sharp edges or bouncing have a tendency to snag the rotating accessory and cause loss of control or kickback.
- e) **Do not attach a saw chain woodcarving blade or toothed saw blade.** Such blades create frequent kickback and loss of control.

Safety Warnings Specific for Grinding Operations

- a) **Use only wheel types that are recommended for your power tool and the specific guard designed for the selected wheel.** Wheels for which the power tool was not designed cannot be adequately guarded and are unsafe.
- b) **The guard must be securely attached to the power tool and positioned for maximum safety, so the least amount of wheel is exposed towards the operator.**
The guard helps to protect operator from broken wheel fragments and accidental contact with wheel and sparks that could ignite clothing.
- c) **Wheels must be used only for recommended applications. For example: do not grind with the side of cut-off wheel.** Abrasive cut-off wheels are intended for peripheral grinding, side forces applied to these wheels may cause them to shatter.
- d) **Always use undamaged wheel flanges that are of correct size and shape for your selected wheel.**
Proper wheel flanges support the wheel thus reducing the possibility of wheel breakage. Flanges for cut-off wheels may be different from grinding wheel flanges.
- e) **Do not use worn down wheels from larger power tools.** Wheel intended for larger power tool is not suitable for the higher speed of a smaller tool and may burst.

Residual Risks



In spite of the application of the relevant safety regulations and the implementation of safety devices, certain residual risks cannot be avoided. These are:

- Impairment of hearing
- Risk of personal injury due flying particles.
- Risk of burns due to accessories becoming hot during operation.

- Risk of personal injury due to prolonged use.
- Risk of dust from hazardous substances.

Tool Symbols

The following symbols are printed on the tool:

-  Read the instruction manual before use.
-  Please wear hearing protectors.
-  Please wear eye protection equipment.

Position of date barcode (fig. 1)

The date barcode (n), including the year of manufacturing, is printed on the tool housing.

E.g.:

2013 XX JN
Year of manufacturing

Package Content

This product package includes:

- 1 Angle grinder
- 1 Guard
- 1 Flange set
- 1 Spanner
- 1 Handle
- 1 Instruction manual
- Check the tool, parts, and accessories to see if they are damaged during transportation.
- Take a few moments to read and understand this manual before using the tool.

Description (Fig. 1)



Warning! Never modify the power tool or any part of the tool, otherwise it may cause damage to the tool or result in personal injury.

- a. ON/OFF switch
- b. Spindle lock
- c. Guard

Purpose of design

This angle grinder is designed especially for grinding.

Do not use sandpaper discs and grinding wheels other than those with depressed center.

Do not use the tool in wet conditions or environments in the presence of flammable liquids or gases.

This heavy-duty angle grinder is a professional power tool.

Do not allow children to come in contact with this tool. Inexperienced operators are required to use this tool under supervision.

Electrical Equipment Safety

Only one voltage is applicable to this tool. Be sure to check that the power supply corresponds to the voltage on the rating plate.

 Your Black & Decker tool is equipped with double insulation, hence, it does not require to be earthed.

When the power cord is damaged, have it sent to a Black & Decker service center for replacement to specially prepared cables.

Using Extension Cords

If an extension cord is required, please select a 3-phase extension cord that has been inspected and matches the input power (see Technical Data) of this tool. The minimum conductor size is 1.5mm², maximum length is 30 meters.

When using a cable reel, be sure to pull out all the cables.

Assembly and Adjustment

 **Warning!** To minimize the danger of serious personal injury, please switch off the tool power and disconnect all plugs before adjusting or removing/installing any accessory. Before reassembling the tool, press and release the trigger switch to make sure the tool is already switched off.

Attaching and Removing the Wheel Guard (Fig. 2)

 **Warning!** To minimize the danger of serious personal injury, please switch off the tool

power and disconnect all plugs before adjusting or removing/installing any accessory. Before reassembling the tool, press and release the trigger switch to make sure the tool is already switched off.

Attaching the guard

1. Place the angle grinder on a work bench, groove facing up.
2. Bring the flange of the guard (c) collar over the groove (i) of the gear housing.
3. Turn the guard (c) clockwise by 180 degrees.
4. Make sure that the screws (k) are tightened.

Removing the guard

1. Loosen the screws (k) on the guard collar.
2. Pull up the guard (c).



Warning! Do not operate the tool when the safety guard is not in place.

Note: Refer to the **grinding accessories chart** at the end of this section for accessories that can be used together with this angle grinder.

Attaching and Removing Grinding Wheels (Fig. 3, 4)



Warning! Do not use damaged grinding wheels.

1. Place the tool on a work bench, groove facing up.
2. Attach the inner flange (d) correctly on the output shaft (e) (Fig. 3).
3. Place the grinding wheel (f) on the inner flange (d). When attaching a grinding wheel with a raised center, make sure that the raised center (g) faces the inner flange (d).
4. Tighten the outer flange (h) until the output shaft (e) (Fig. 4). When attaching the grinding wheel, the ring on top of the outer flange (h) must face the wheel.
5. Press the spindle lock (b) and prevent the spindle (e) from rotating until it locks in place.
6. Use the pin spanner to tighten the outer flange (h).

Preparation Before Use

- Attach the safety guard and appropriate abrasive or grinding wheels. Do not use abrasive or grinding wheels that are overly worn.
- Make sure that the inner and outer flanges are attached correctly.
- Make sure that the abrasive or grinding wheels are rotating in the direction of the arrows on the accessories and tool.

Operation (Fig. 5)

Instructions



Warning! Always observe the safety instructions and applicable regulations.



Warning! To minimize the danger of serious personal injury, please switch off the tool power and disconnect all plugs before adjusting or removing/installing any accessory. Before reassembling the tool, press and release the trigger switch to make sure the tool is already switched off.



Warning!

- Make sure all materials to be grinded are secured in position.
 - Apply slight pressure to the tool. Do not apply side pressure to the abrasive disc. • Avoid overloading. If the tool becomes hot, let it spin for a few minutes with no load.
1. Be sure to hold the tool tightly with both hands (one hand on housing, the other on side handle). Start the tool and bring the grinding wheel on the workpiece.
 2. Keep the edge of the wheel tilted at angle from 15 to 20 degrees against the surface of the workpiece.
 3. When using a new grinding wheel, do not operate the wheel in the B direction, otherwise, it will cut into the workpiece. When the edge of wheel has been rounded off, you are free to operate the grinder in either the A or B direction.

Starting and Stopping (Fig. 1)



Warning! Before using the tool, check whether the handle is tightened securely. Check whether the ON/OFF switch is working normally.

Before plugging in the tool to the power supply, check whether the switch is in the OFF (o) position when pressing the rear end of the switch.

To start the tool, press the rear end of the switch and slide it forward. Then press the front end of the switch to lock it. Press the rear end of the switch to stop the tool.



Warning! Do not switch the tool on or off while under load conditions.

Proper Hand Position (Fig. 6)



Warning! To reduce the risk of serious personal injury, **ALWAYS** use proper hand position as shown.



Warning! To reduce the risk of serious personal injury, **ALWAYS** hold securely in anticipation of a sudden reaction.

Proper hand position requires one hand on the side handle (figure 1), with the other hand on the body of the tool, as shown in figure 6.

Switches



Caution: Hold the body of the tool firmly to maintain control of the tool at start up and during use and until the wheel or accessory stops rotating. Make sure the wheel has come to a complete stop before laying the tool down.

Note: To reduce unexpected tool movement, do not switch the tool on or off while under load conditions. Allow the grinder to run up to full speed before touching the work surface. Lift the tool from the surface before turning the tool off. Allow the tool to stop rotating before putting it down.

Slider switch (fig. 1)



Warning! Before connecting the tool to a power supply, be sure the slider switch is in the off

position by pressing the rear part of the switch and releasing. Ensure the slider switch is in the off position as described above after any interruption in power supply to the tool, such as the activation of a ground fault interrupter, throwing of a circuit breaker, accidental unplugging, or power failure. If the slider switch is locked on when the power is connected, the tool will start unexpectedly.

To start the tool, slide the slider switch (a) toward the front of the tool. To stop the tool, release the slider switch. For continuous operation, slide the switch toward the front of the tool and press the forward part of the switch inward. To stop the tool while operating in continuous mode, press the rear part of the slider switch and release.

Spindle lock (Fig. 1)

The spindle lock (b) prevents the output shaft from rotating when attaching or removing the grinding wheel. Only use the spindle lock when the tool is switched off, power is unplugged, and wheel stops completely.



Note: To minimize tool damages, don't use the spindle lock when the tool is operating. Otherwise, it may damage the tool. The attached accessories may come off and cause injury.

If using the spindle lock, press the spindle lock button and rotate the output shaft until it stops.

Application on Metals

When applying the tool on metals, make sure that a residual-current device (RCD) is inserted to prevent danger from metal chips.

If the RCD causes power disconnection, have the tool sent to an authorized Black & Decker dealer for repair.



Warning! Under extreme working conditions, conductive dust and grit may accumulate on the housing interior when handling metal

workpieces. This could create an electric shock hazard as it weakens the protective insulation in the grinder.

To avoid accumulation of metal chips in the interior of the grinder, we recommend cleaning the ventilation ducts daily. Refer to **Maintenance**.

Using Grinding Wheels



Warning! Metal powder accumulates.

Excessive use of the grinding wheel on metals may increase the risk of electric shock. To reduce the risk, insert the RCD before use and clean the ventilation ducts daily. Follow the maintenance instructions below to blow dry compressed air into the ventilation ducts.

Maintenance

Black & Decker power tools have been designed to operate over a long period of time with minimal maintenance. Continuous satisfactory operation depends upon proper tool care and regular cleaning.



Warning! To minimize the danger of serious personal injury, please switch off the tool power and disconnect all plugs before adjusting or removing/installing any accessory. Before reassembling the tool, press and release the trigger switch to make sure the tool is already switched off.



Lubrication

This power tool does not require separate lubrication.



Cleaning



Warning! Once visible dust accumulates on the ventilation ducts and the surrounding, immediately use dry air to blow away dust and grit out of the interior of the housing. You need to wear approved eye and facial protective gear when performing this process.



Warning! Never use solvents or harsh chemicals to clean non-metal parts of the tool. These chemicals may weaken the material of the parts. Use only mild soap and damp cloth to clean the tool. Never let any liquid get inside the tool; never immerse any part of the tool into liquid.

Accessories

Warning! Excluding accessories provided by Black & Decker, all other accessories have not been tested for product compatibility. Using such accessories together with this tool may cause safety hazards. To minimize the risk of personal injury, we recommend you to use only Black & Decker accessories with this product.

Please inquire at your dealer for more information regarding suitable accessories.

Technical Data

		BPGS8100	BPGS8115
Input power	W	850	850
No-load speed/rated speed	/min	11,000	11,000
Wheel diameter	mm	100	115
Grinding wheel thickness	mm	6	6
Type of wheel		27	27
Spindle diameter		M10	M14
Weight	kg	2.2	2.2

Protecting the environment



Separate collection. This product must not be disposed of with normal household waste.

Should you find one day that your Black & Decker product needs replacement, or if it is of no further use to you, do not dispose of it with household waste. Make this product available for separate collection.



Separate collection of used products and packaging allows materials to be recycled and used again. Reuse of recycled materials helps prevent environmental pollution and reduces the demand for raw materials.

Local regulations may provide for separate collection of electrical products from the household, at municipal waste sites or by the retailer when you purchase a new product.

Black & Decker provides a facility for the collection and recycling of Black & Decker products once they have reached the end of their working life. To take advantage of this service please return your product to any authorised repair agent who will collect them on our behalf.

You can check the location of your nearest authorised repair agent by contacting your local Black & Decker office at the address indicated in this manual. Alternatively, a list of authorised Black & Decker repair agents and full details of our after-sales service and contacts are available on the Internet at: www.2helpU.com.

Remarks

- Black & Decker's policy is one of continuous improvement to our products and as such, we reserve the right to modify product specifications without prior notice.
- Standard equipment and accessories may vary by country.
- Product specifications may differ by country.
- Complete product range may not be available in all countries. Contact your local Black & Decker dealers for range availability.