

# DLS.400

## 843307

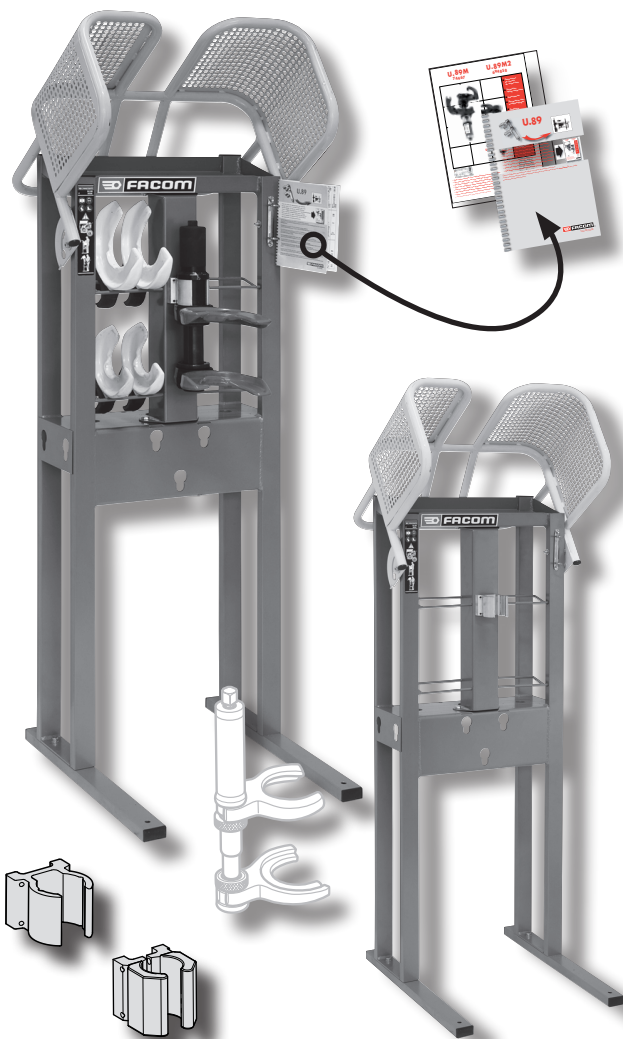

- Poste de travail
- Workstation
- Arbeitsplatz
- Werkplek
- Puesto de trabajo
- Postazione di lavoro
- Posto de trabalho
- Stanowisko pracy
- Arbeitsstation
- Θεσεις εργασίας

Notice d'instructions  
Instruction manual  
Bedienungsanleitung  
Gebruiksaanwijzing  
Guia de instrucciones  
Istruzioni per l'utilizzo  
Manual de instruções  
Brugsanvisning  
Οδηγίες χρήσεως



**DLS.400**  
**843307**

NU-DLS.400/0110

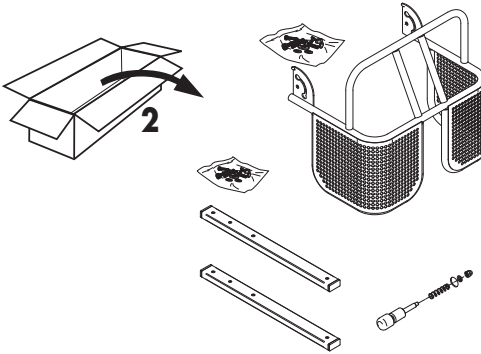
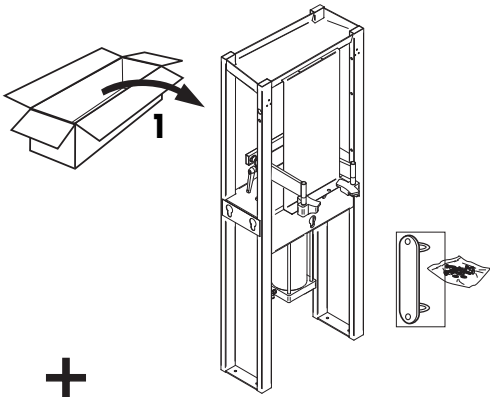

34 kg



Q.NU-DLS.400/0110



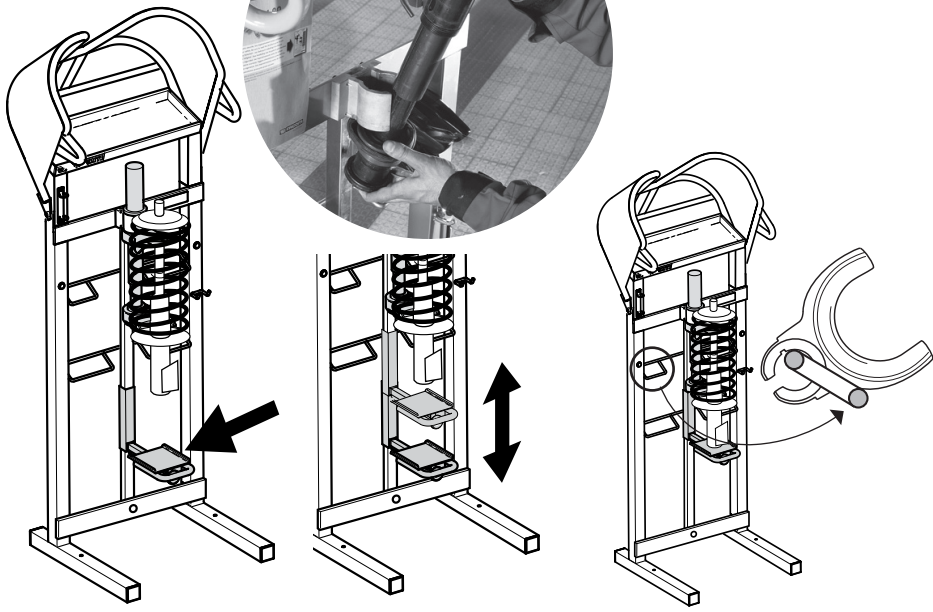
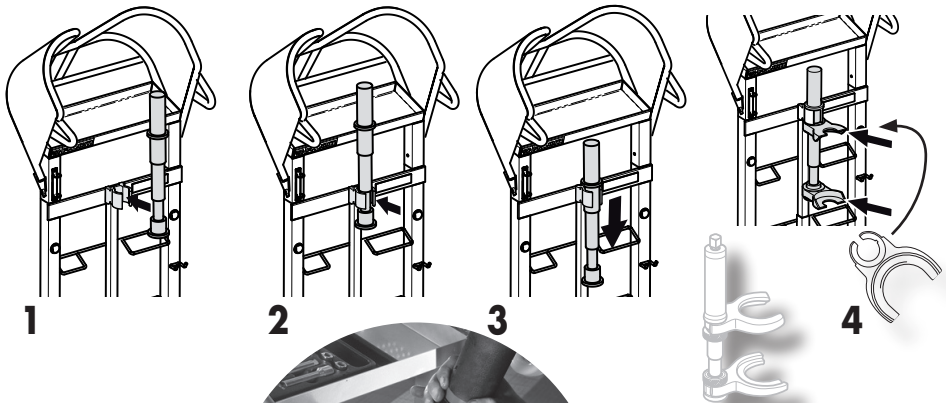
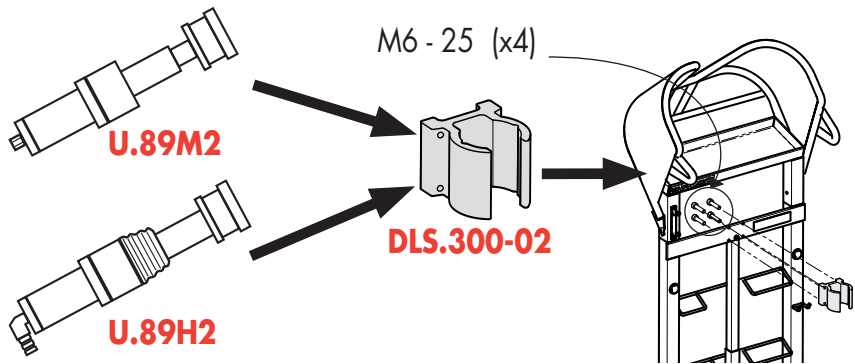

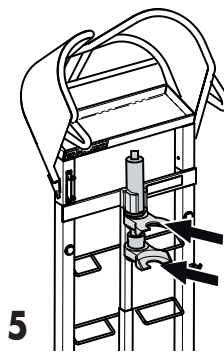
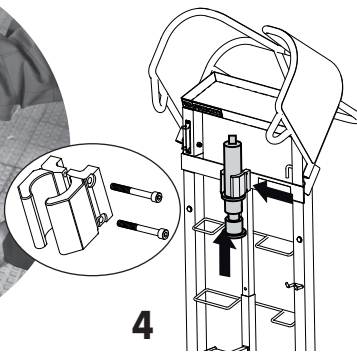
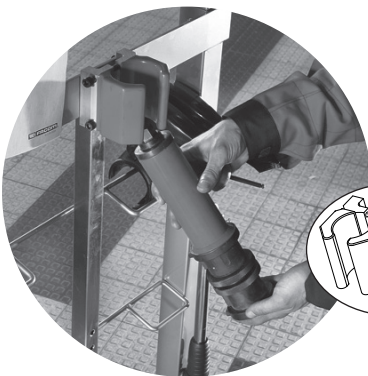
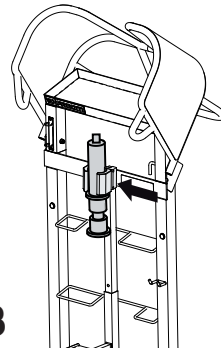
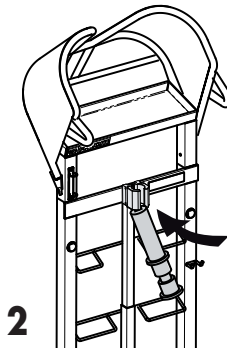
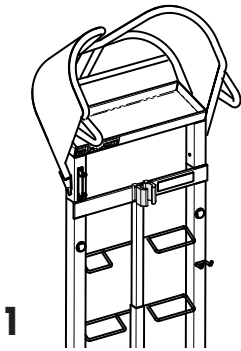
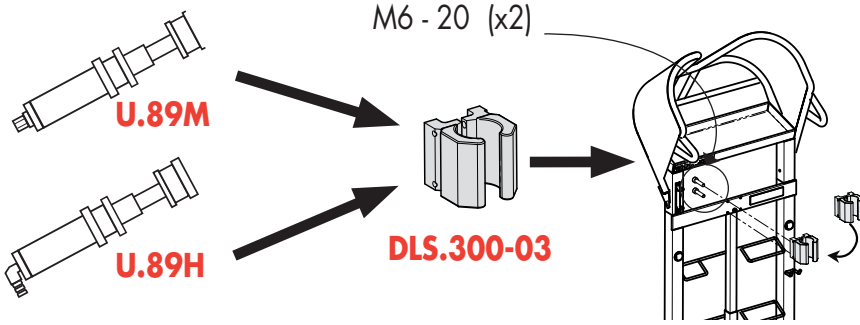

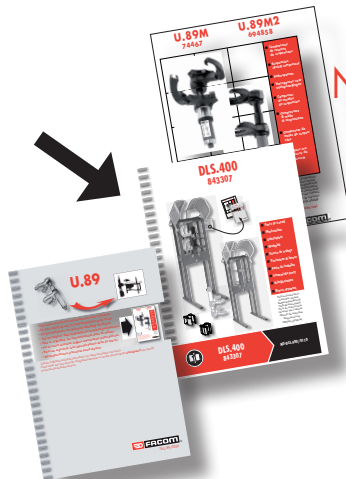
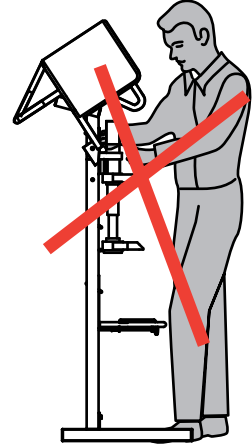
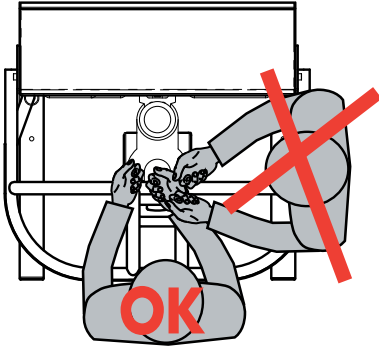



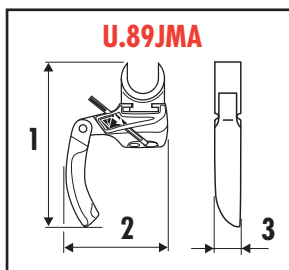
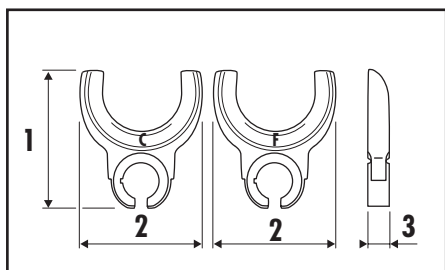

NU-U.89/1005

NU-DLS.400/0110

TA-U.89/0606



	 $\varnothing$ mm		1 mm	2 mm	3 mm	 kg
	mini	maxi				
U.89J1C U.89J1F	99	156	190	172	36,5	2,08 2,135
U.89J2C U.89J2F	129	174	207	194	36,5	2,215 2,215
U.89J3C U.89J3F	139	218	220	232	36,5	2,345 2,85
U.89J4C U.89J4F			216 181	150 120	36,5 36,5	1,55 1,55
U.89J5C U.89J5F	71	119	165	139	36,5	1,705 1,76
U.89J12C U.89J12F	145	170	260	145 185	45 40	2,140 2,190
U.89J14C U.89J14F	170	195	295 285	165 160	67 27	2,675 2,365
U.89JMA	105	210	180	275	42	3,300

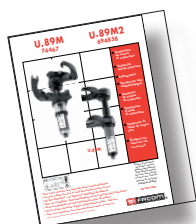

NU-U.89/1005

- Pour votre sécurité, lire impérativement avant utilisation.
- For your safety, be sure to read this brochure prior to use.
- Für Ihre Sicherheit : vor Gebrauch unbedingt durchlesen.
- Voor uw veiligheid : Deze handleiding voor het gebruik goed doorlezen.
- Para su seguridad, lea imperativamente antes de utilizar.
- Per la vostra sicurezza, leggere attentamente prima dell'uso.
- Para sua segurança, leia imperativamente antes de intervir
- Dla bezpieczeństwa, przeczytać przed użyciem.

Option - Option - Option - Optie - Opción - Opzione - Opção - Option

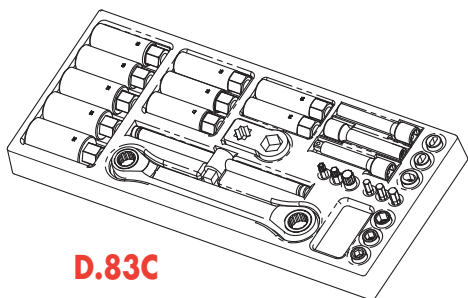

**D.83C**

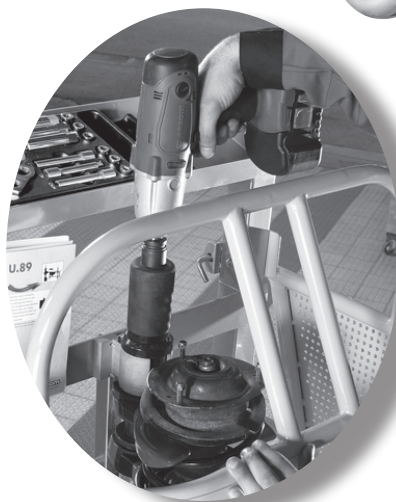

**CL2.C1913**



**S.208-100**



**[www.facom.com](http://www.facom.com)**



**BELGIQUE**  
**LUXEMBOURG** FACOM Belgique B.V.B.A.  
Egide Walschaertsstraat 14-16  
2800 MECHELEN  
BELGIQUE  
☎ : +32 (0) 15 47 39 35  
Fax : +32 (0) 15 47 39 71

**NETHERLANDS** FACOM Gereedschappen BV  
Martinus Nijhofflaan 2  
2624 ES DELFT  
P.O. BOX 1007. 2600 BA Delft  
NETHERLANDS  
☎ : 0800 236 236 2  
Fax : 0800 237 60 20

**DANMARK** FACOM NORDEN  
**FINLAND** Nordre Strandvej 119B  
**ISLAND** 3150 HELLEBÆK  
**NORGE** DENMARK  
**SVERIGE** ☎ : +45 49 76 27 77  
Fax : +45 49 76 27 66

**SINGAPORE** FACOM TOOLS FAR EAST  
**FAR EAST** N° 25 Senako South Road  
Woodlands East Industrial Estate  
Singapore 758081  
SINGAPORE  
☎ : (65) 6752 2001  
Fax : (65) 6752 2697

**DEUTSCHLAND** FACOM GmbH  
Stanley Deutschland GmbH  
Otto-Hahn-Straße 9  
42369 Wuppertal  
DEUTSCHLAND  
☎ : +49 202 69 819-329  
Fax : +49 202 69 819-350

**SUISSE** FACOM WERKZEUGE GMBH  
**ÖSTERREICH** Ringstrasse 14  
**MAGYARORSZAG** 8600 DÜBENDORF  
**ČESKÁ REP.** SUISSE  
☎ : 41 44 802 8093  
Fax : 41 44 802 8091

**ESPAÑA** FACOM Herramientas S.L.  
**PORTUGAL** Poligono industrial de Vallecas  
C/Luis 1º, s/n-Nave 95 - 2ºPl.  
28031 Madrid  
ESPAÑA  
☎ : +34 91 778 21 13  
Fax : + 34 91 380 65 33

**UNITED** FACOM-UK  
**KINGDOM** Europa view  
**EIRE** SHEFFIELD BUSINESS PARK  
Europa link  
SHEFFIELD S9 1 XH  
ENGLAND  
☎ : (44) 114 244 8883  
Fax : (44) 114 273 9038

**ITALIA** SWK Utensilerie S.r.l.  
Via Volta 3  
21020 Monvalle (VA)  
ITALIA  
☎ : (0332) 790 381  
Fax : (0332) 790 307

**POLSKA** FACOM Tools Polska Sp. zo.o.  
ul.Madlińska 190  
03-119 Warszawa  
POLSKA  
☎ : (48 22) 510-3627  
Fax : (48 22) 510-3656

#### FRANCE & INTERNATIONAL

FACOM S.A.S.  
6-8, rue Gustave Eiffel B.P.99  
F-91423 Morangis cedex  
FRANCE  
☎ : 01 64 54 45 45  
Fax : 01 69 09 60 93  
<http://www.facom.com>

En France, pour tous renseignements techniques sur l'outillage à main, téléphonez au : 01 64 54 45 14

